

---

# USER MANUAL

---

*Simpro Multi-Tip®*





Copyright © 2019 Simpro Handling Equipment Ltd.

No part of this document may be reproduced or transmitted in any form or by any means, electronic, mechanical, photocopying, recording, or otherwise, without the written permission of Simpro Handling Equipment Ltd.

For the purposes of standards compliance and international conformity, this document uses Système International (SI) units. These may be converted to Imperial units as follows:

1 kilogram (kg) = 2.2 pounds (lb)

1 metre (m) = 1000 millimetres (mm) = 39.37 inches (in) = 3.28 feet (ft) = 1.09 yards (yd)

The following stylistic conventions are used throughout this document:

 Text in GREEN indicates a point of interest.

 Text in RED indicates a point of warning or a safety hazard.

Errors in this document should be reported by email to [info@simpro.world](mailto:info@simpro.world)

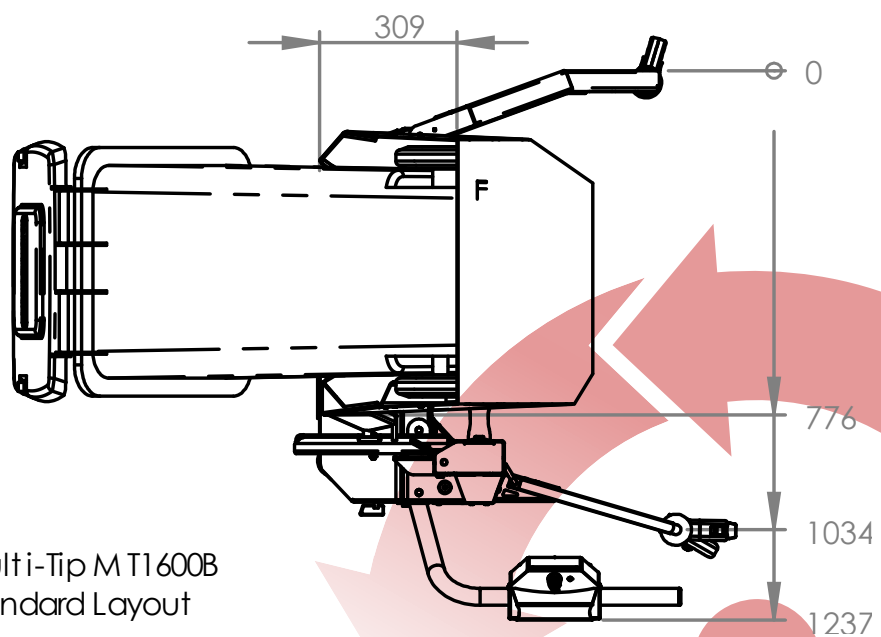
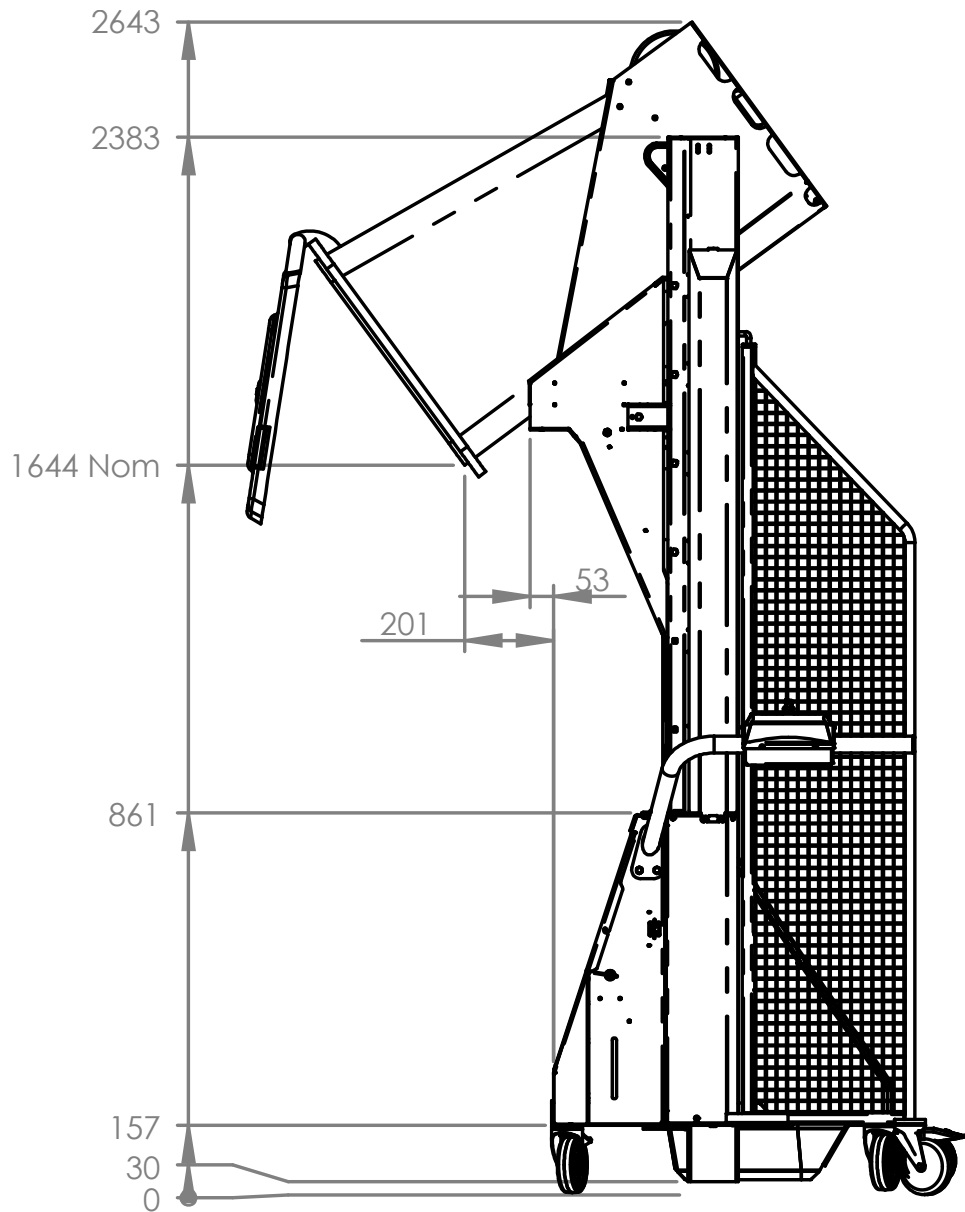

Multi-Tip M T1600B  
Standard Layout

# I. Contents

1. Contents.....	3
2. Product Overview.....	5
2.1 Key Features .....	6
2.2 Construction .....	6
2.3 Mechanism .....	6
2.4 Safe Lifting Capacity .....	6
2.5 Duty cycle.....	7
2.6 Intended operational life .....	7
2.7 Noise emissions.....	7
2.8 Environmental restrictions .....	8
2.9 Ingress protection .....	8
2.10 Notes .....	8
3. Safety Assessment .....	9
3.1 Safety features .....	9
3.2 Reasonably foreseeable misuse .....	9
3.3 OSH Compliance Specification Guide .....	9
3.3.1 The ISO 13849-1:2015 safety model.....	10
3.4 Hazard and Risk Assessment Guide.....	11
3.4.1 ISO 12100:2010 risk assessment model.....	12
3.4.2 Identified Hazards .....	13
3.4.3 Residual Hazards .....	16
3.5 Safety Norms.....	17
4. Operating Instructions .....	19
4.1 Before operation.....	19
4.2 Emplacing and removing bins .....	19
4.2.1 Cradle identification.....	19
4.2.2 EN840 Base-lift Cradle (standard) .....	21
4.2.3 EN840 Comb-lift Cradle.....	21
4.2.4 ANSI Bar-lift Cradle .....	21
4.2.5 ANSI Bar-lift Cradle with base .....	22
4.2.6 Trunnion-lift Cradle (DIN9797 Eurobins & Foodcap®).....	22
4.2.7 Combi-Cradle and Custom Cradle .....	22
4.3 Operation of controls .....	23
5. Care and Maintenance.....	25

5.1	Quick Troubleshooting Guide.....	25
5.2	Cleaning .....	26
5.3	Cradle jams .....	26
5.4	Electrical System (battery) .....	28
5.4.1	Localisation.....	28
5.4.2	Voltmeter .....	28
5.4.3	Battery charging .....	28
5.4.4	Batteries and battery care.....	29
5.4.5	Smart charger .....	29
5.4.6	IEC power lead .....	29
5.4.7	Isolator switch .....	29
5.4.8	Overload fuse.....	29
5.4.9	Solar panel.....	30
5.5	Electrical System (3-phase mains) .....	31
5.5.1	Localisation.....	31
5.5.2	Transformer .....	31
5.6	Electrical System (1-phase mains) .....	32
5.6.1	Localisation.....	32
5.6.2	Transformer .....	32
5.6.3	Variable Speed Drive .....	32
5.7	Hydraulic System .....	33
5.7.1	Powerpack .....	33
5.7.2	Control valves.....	33
5.7.3	Lift Ram .....	33
5.7.4	Hydraulic fluid.....	33
5.7.5	Maintenance.....	33
5.7.6	Hydraulic system schematic .....	34
6.	Assembly, Handling, Transport & Storage.....	35
7.	Safety Inspections.....	37
7.1	Pre-inspection checklist .....	37
7.2	Monthly inspection .....	37
7.3	Annual inspection .....	39
8.	Spare Parts .....	41
9.	Warranty.....	43
10.	EC Declaration of Conformity.....	45
11.	Notes .....	46

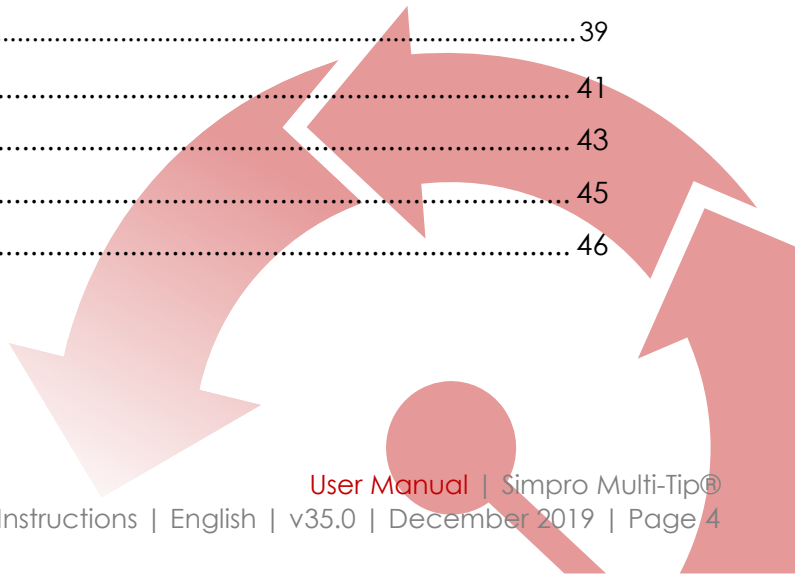

## 2. Product Overview

Congratulations on your purchase of a Simpro Multi-Tip. The Multi-Tip is everything a bin lifter should be - safe, reliable, cost-effective and easy to use. With a 150kg lifting capacity and 15-second tipping cycle, it is ideal for emptying bins at schools, factories and events centres.

The Multi-Tip has a single-mast design which gives the operator a clear view of operations to ensure safety. No cage-guard is needed, because the two-hand control system prevents the operator from being able to access any moving parts while using the machine. The Multi-Tip design is also very easy to clean and maintain.

The standard Multi-Tip models dump bins at 1.2m, 1.6m or 1.8m, and are fitted with a cradle which suits most standard wheelie bins with no clamping or modification. However, Simpro's modular design means the Multi-Tip can be quickly adapted to empty almost any container weighing up to 150kg - including US-style trash carts, BRUTE® bins, 205-litre drums and even custom bins.

Like all Simpro products, the Multi-Tip is extremely robust and requires no regular maintenance.



As far as compliance and relieving me of hard work, this is the best -  
absolutely the best!

Graham Hawkes – Caretaker – One Tree Hill College

## 2.1 Key Features

Key features of the Multi-Tip include:

1. A unique tipping action whereby bins are lifted straight up, and then gently rolled forward around the lip of the container being emptied into. Benefits of this design include a small 'footprint' and high stability in use.
2. A large lifting capacity of 150kg.
3. A reliable, maintenance-free design.
4. A powder-coated frame and zinc-plated cradle for corrosion protection.
5. A modular cradle architecture which can be easily adapted to suit different bins.
6. A retaining system for most common bins which does not require clamping or fasteners – simply place the bin on the cradle and press the 'Raise' button.

## 2.2 Construction

The Multi-Tip consists of a steel frame with one vertical mast, a bin cradle, one hydraulic ram, guarding, castor wheels, powerpack cover, grab handle with control buttons, power lead or battery, hydraulic powerpack and control systems.

## 2.3 Mechanism

When operated, the bin cradle moves vertically in the masts, and is inverted at the appropriate height by a 'follower roller' running in a 'guide track'. A hydraulic ram provides the force to lift the bin. The ram is operated by a hydraulic powerpack, which is normally powered by a battery. Electronic control systems allow the operator to raise or lower the bin in a controlled manner.

## 2.4 Safe Lifting Capacity

The Safe Lifting Capacity of the standard model Multi-Tip is **150 kilograms (330lb)**.

Some machines may be specified with different capacities to suit custom requirements. Refer to the machine's rating plate to verify the factory-designated Safe Lifting Capacity on any given machine.

 Safe Lifting Capacity is a gross figure, referring to the weight of the bin, its contents, and any other external objects which have been placed on the cradle.

 Never attempt to lift more than the factory-designated Safe Lifting Capacity noted on the rating plate.

## 2.5 Duty cycle

The duty cycle of the Multi-Tip depends on the type of power supply and powerpack that is fitted to the machine, as well as environmental factors and the manner in which the machine is used. The figures given below are estimates only.

Duty Cycle (tipping at 1600mm)			
Power Supply	Throughput (net tipped material)	No. of bins equivalent (average ~100kg each)	Units
21Ah Battery	2,500kg	25 bins	per charge
55Ah Battery	6,000kg	60 bins	per charge
Battery + Continuous Charge	1,500kg	15 bins	per hour, nonstop
Battery + Solar Panel	2,000kg	20 bins	per day (in mostly sunny conditions)
1-Phase Mains	6,000kg	60 bins	per hour, nonstop
3-Phase Mains	12,000kg	120 bins	per hour, nonstop

 The standard Multi-Tip uses a battery power supply. Check the rating plate of your machine if you are unsure of what type of power it uses.

## 2.6 Intended operational life

The intended operational life of the Multi-Tip is as follows.

Average Gross Bin Weight	Intended operational life
< 50kg	100,000 cycles
50kg – 100kg	75,000 cycles
100kg – 150kg	50,000 cycles
> 150kg	10,000 cycles

## 2.7 Noise emissions

The noise emissions of the Multi-Tip bin lifter in standard operation have been assessed as not exceeding ~60 dB(A) at the operator's ear.

Operators are not required to wear hearing protection but are recommended to do so if using the machine on a constant basis.

 ISO standards for machinery safety specify that noise emissions are to be measured in A-weighted decibels (dB(A)), a unit of volume which is adjusted to reflect the sensitivity of human hearing. The measurements are taken at a point 1.6 metres above the ground at the operator's working position.



## 2.8 Environmental restrictions

The Multi-Tip may be used indoors or outdoors. However, the following restrictions apply:

1. A minimum floor area of two square metres, with a clear passage to exits;
2. Height above sea level not more than 1000m;
3. Ambient temperature not higher than +40°C and not lower than -10°C;
4. At ambient temperatures above 35°C, the relative humidity should not exceed 50%; at lower temperatures, higher relative humidity is permitted;

**⚠ Never operate the machine in flammable, explosive, corrosive, acidic or alkaline environments.**

## 2.9 Ingress protection

Item	IP Rating
Push buttons, switches and lamps	IP66
Door interlock	IP66
Coded magnetic switch	IP66
Motor	IP54 (note additional protection provided by covers)
Overall	IP56 (optional upgrade to IP66 or IP69K)

## 2.10 Notes

1. This User Manual describes approved procedures for the operation, maintenance, and routine inspection of the Multi-Tip hydraulic bin-tipping machine.
5. This manual is written in English, and is to be considered the 'Original Instructions' for the purposes of Machinery Directive 2006/42/EC.
6. Operator(s) must read and understand this manual before using the machine.
7. If the machine is to be leased, then this manual shall accompany the machine.
8. This is a generic manual. Simpro reserves the right to change the design of our products at any time without notification. In cases where the manual does not correspond with the actual product, use the manual as a reference guide only, and contact your authorized Simpro agent for assistance if required.
9. Contact your authorized Simpro agent if you encounter any problems or faults with the machine.
10. Any errors in this manual should be reported by email to [info@simpro.world](mailto:info@simpro.world).

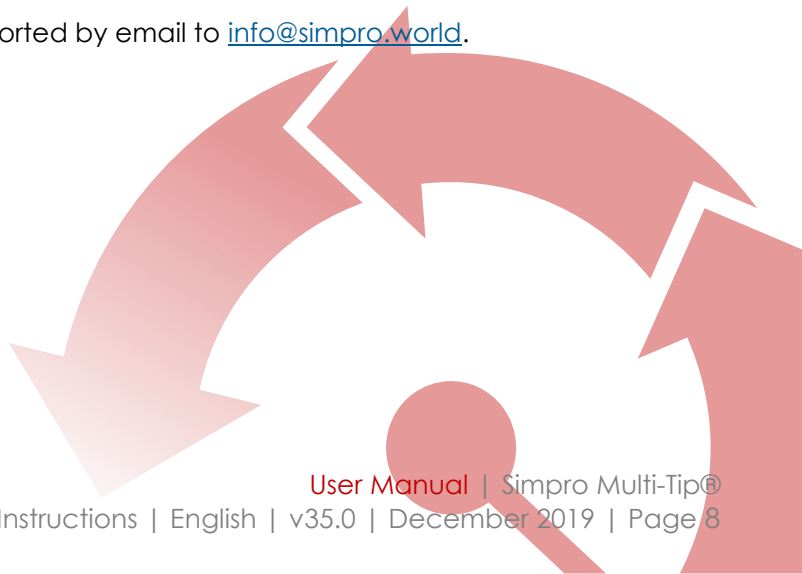

## 3. Safety Assessment

The Multi-Tip has been designed to be as safe as possible without restricting the ease-of-use and versatility of the machine.

 A Hazard and Risk Assessment should be undertaken before the Multi-Tip is used for the first time, as described in [Section 3.4](#).

### 3.1 Safety features

The safety features of the Multi-Tip are as follows:

1. A shrouded dual-hand control system, which immediately stops the cradle whenever the 'Raise', 'Lower' or 'Safety' buttons are released.
2. A welded mesh panel which physically prevents the operator from accessing moving parts while using the machine.
3. A tipping action which maintains the weight of the bin within the machine footprint.
4. A pressure-compensating lowering valve which automatically regulates the lowering speed regardless of the weight of the bin.

### 3.2 Reasonably foreseeable misuse

The reasonably foreseeable misuse considered in the Multi-Tip design is as follows:

1. Attempts to use the machine by untrained operators;
2. Attempts to empty bins that the cradle is not specifically designed to hold;
3. Attempts to bypass dual-hand controls or other safety systems;
4. Attempts to access the operational area beneath the cradle without following proper procedures;
5. Attempts to clean the machine without following proper procedures.

### 3.3 OSH Compliance Specification Guide

Companies in most jurisdictions (including Australia, NZ, UK, USA, Canada and the EU) are required by law to provide a safe workplace for their staff, including ensuring that all new and existing machinery is safe to operate.

Although the particulars of safety legislation differ, most countries accept that machinery is 'safe to operate' if it can be demonstrated to **comply with ISO 13849-1:2015 (or a regional equivalent thereof)**.

ISO 13849-1:2015 may call for additional guarding and safety features, depending on the particular circumstances in which a machine is to be used. The purpose of this section is to assist potential Multi-Tip owners to determine whether special safety features may be required on their machine.

- ⚠ ISO 13849-1:2015 is a machinery-safety standard issued by the International Standards Organisation. It provides safety requirements and guidance on the principles for the design and integration of safety-related parts of control systems (SRP/CS), including the design of software.
- ⚠ ISO 13849-1 has been modified for local conditions and reissued under different terminology by some national standards authorities. In Australia and New Zealand the equivalent (almost identical) standard is called AS/NZS 4024.1:2014.
- ⚠ In the USA, ANSI standards are commonly used to demonstrate the safety of machinery, rather than ISO 13849-1. However since the US model relies largely on 'best practise' and 'liability' to enforce workplace H&S norms, US companies who demonstrate machinery safety using ISO 13849-1 may be considered to have met or exceeded their H&S obligations.

### 3.3.1 The ISO 13849-1:2015 safety model

Unlike the 'system architecture' model used by earlier safety standards, ISO 13849-1:2015 uses a 'functional safety' model of machinery safety. That is, it takes account of the reliability of parts as well as other factors to create a comprehensive measure of the risk reduction achieved by a safety function – an indicator called **Performance Level (PL)**.

The standard defines five Performance Levels, ranging from **PL(a)** (lowest performance) to **PL(e)** (highest performance).

The standard also defines the Performance Level that a given safety function must achieve to reduce the risk to an acceptable level – a value called **Performance Level required (PLr)**.

#### 3.3.1.1 Determining the Performance Level required (PLr)

As defined by the ISO 13849-1:2015 safety model, the minimum acceptable PLr for any given safety function is based on three input parameters:

1. Severity of injury expected from the associated hazard
2. Frequency and/or duration of exposure to the associated hazard
3. Possibility of manually avoiding the associated hazard

The following table may be used to determine the acceptable PLr from these parameters.

Safety Function PLr Determination Table			
Severity of injury expected from hazard	Frequency and/or duration of exposure to hazard	Possibility of manually avoiding the hazard	Minimum acceptable PLr
Slight injury (reversible)	Seldom to quite often and/or exposure time is short	Possible under specific conditions	<b>PL(a)</b>
		Scarcely possible	<b>PL(b)</b>
	Frequent to continuous and/or long exposure time	Possible under specific conditions	<b>PL(b)</b>
		Scarcely possible	<b>PL(c)</b>
Serious injury or death (irreversible)	Seldom to quite often and/or exposure time is short	Possible under specific conditions	<b>PL(c)</b>
		Scarcely possible	<b>PL(d)</b>
	Frequent to continuous and/or long exposure time	Possible under specific conditions	<b>PL(d)</b>
		Scarcely possible	<b>PL(e)</b>

To demonstrate compliance with ISO 13849-1:2015, the minimum acceptable PLr of the safety functions must be assessed **for each identified hazard in the specific conditions in which the machine is to be used.**

 The safety function PLr may be assessed as part of the regular Hazard and Risk Assessment described in [Section 3.4](#). Although this assessment includes all hazards intrinsic to the Multi-Tip design, other safety functions may be necessary to address hazards specific to your intended conditions of use. These can be assessed in the blank spaces provided.

### 3.3.1.2 Achieving the Performance Level required (PLr)

As standard, all hazards intrinsic to the Multi-Tip design are addressed by safety functions **with a minimum performance of PL(c).**

Therefore, additional or customised safety systems are only required in the following cases:

1. The customer's assessment identifies that hazards exist which have been addressed in the standard Multi-Tip design, but which, due to conditions specific to their intended conditions of use, require safety function performance of PL(d) or PL(e).
2. The customer's assessment identifies that hazards exist which are entirely specific to their intended conditions of use, and which have therefore not been addressed in the standard Multi-Tip design.
3. The customer is subject to corporate policies, union contracts, OSH regulations or other external factors which demand safety function performance of PL(d) or PL(e), irrespective of the ISO 13849-1:2015 safety model.

In any of these cases, information about the required safety function PLr should be provided to Simpro before placing an order. Simpro will then propose additional or updated systems to achieve the PLr in compliance with ISO 13849-1:2015. This may include any or all of the following:

- Upgrade of control system architecture to Category 3 or Category 4
- Additional guarding panels
- Remote control systems
- Training of personnel
- Signage and floor markings

## 3.4 Hazard and Risk Assessment Guide

Most jurisdictions require machinery owners to conduct a Hazard and Risk Assessment for their equipment, which considers all relevant factors such as the area it is used, the skill and training of operators, the proximity of other persons, frequency of use, etc.

The following section is not a complete site-specific Hazard and Risk Assessment, but an assessment of the risk factors that are intrinsic to the Multi-Tip design. Blank template spaces are provided for additional site-specific hazards.

 The procedure for carrying out a Hazard and Risk Assessment is typically defined with reference to ISO 12100:2010, issued by the International Standards Organisation. This standard describes procedures for identifying hazards and estimating and evaluating risks during relevant phases of a machine life cycle.

 As with all powered industrial equipment, some hazards will remain despite any precautions undertaken by the manufacturer or owner of the machine. It is essential that operators are aware of these residual hazards and what they must do to prevent harm to themselves or to others, as described in [Section 3.4.3](#).

### 3.4.1 ISO 12100:2010 risk assessment model

In the ISO 12100:2010 risk assessment model, each identified hazard is given a Risk Factor, from which is derived a final Risk Evaluation. These parameters can be determined as follows.

#### 3.4.1.1 Determining Risk Factor

The Risk Factor associated with any given hazard may be calculated using the following table, with the formula: **Risk Factor = LO x FE x DPH x NP**

LO	Likelihood of Occurrence	FE	Frequency of Exposure	DPH	Degree of Possible Harm	NP	Number of Persons at risk
0.1	Impossible, or possible only in extreme circumstances	0.1	Infrequently	0.1	Scratch or bruise	1	1 – 2 persons
0.5	Highly unlikely though conceivable	0.2	Annually	0.5	Laceration, mild ill-health	2	3 – 7 persons
1	Unlikely but could occur	1	Monthly	1	Break minor bone or illness (temporary)	4	8 – 15 persons
2	Possible but unusual	1.5	Weekly	2	Break major bone or illness (permanent)	8	16 – 50 persons
5	Even chance – could happen	2.5	Daily	4	Loss of 1 limb or eye/serious illness (temporary)	12	51 or more persons
8	Probable – not surprised	4	Hourly	8	Loss of 2 limbs or eyes/serious illness (permanent)	-	-
10	Likely, only to be expected	5	Constantly	15	Fatality	-	-
15	Certain, no doubt	-	-	-	-	-	-

#### 3.4.1.2 Determining Risk Evaluation

Once the Risk Factor has been calculated, the Risk Evaluation of the hazard can be determined from the following table:

Risk Factor	0-1	2-5	6-10	11-50	51-100	101-500	501-1000	1001 +
Risk Evaluation	Negligible	Very Low	Low	Significant	High	Very high	Extreme	Unacceptable

### 3.4.2 Identified Hazards

The following hazards have been identified that are intrinsic to the Multi-Tip design. For each hazard a full Risk Evaluation has been completed and control measures described.

 Blank template spaces are provided at the end for machinery owners to identify, assess and control additional site-specific hazards.

Entanglement or amputation of fingers or limbs in moving parts										
Operator	LO:	0.5	FE:	4	DPH:	1	NP:	1	Risk Factor:	2
	Operation of the Multi-Tip requires both hands on the control buttons. This means the operator cannot reach any moving parts while using the machine.									
Other persons	LO:	1	FE:	4	DPH:	1	NP:	1	Risk Factor:	4
	The operator has a good view of the cradle while using the machine, and can instantly stop all movement by removing either hand from the control buttons if any other persons approach the cradle while moving.									
Control measures	Operators are responsible to obey warning signs fitted to the machine and instructions, regarding keeping himself and others clear of all moving parts.									
Comments	The Multi-Tip is designed so trapping hazards are minimized, and both hands are needed to operate the machine.									
Crushing due to unauthorized rapid descent of cradle										
Operator	LO:	0.5	FE:	4	DPH:	2	NP:	1	Risk Factor:	4
	The operator is protected from the cradle by the frame and guarding during operation. There is nothing to stop an operator or other person moving under the cradle while it is inverted. Significant safety margins ensure that the probability of failure of any steel, hydraulic, or control parts failing is low.									
Other persons	LO:	0.5	FE:	4	DPH:	2	NP:	1	Risk Factor:	4
	As above.									
Control measures	Operators are responsible to obey warning signs fitted to the machine and instructions, regarding keeping himself and others away from the area under the cradle when raised. The machine must be regularly maintained, and all faults repaired immediately.									
Comments	A hydraulic speed-control valve limits the maximum speed of descent in normal use.									
Operator or others being hit by falling or flying debris										
Operator	LO:	1	FE:	4	DPH:	0.5	NP:	1	Risk Factor:	2
	The operator is protected from the cradle by the frame and guarding during operation. There is some risk if product such as broken glass is being tipped.									
Other persons	LO:	1	FE:	4	DPH:	0.5	NP:	1	Risk Factor:	2
	There is some risk to persons nearby if product such as broken glass is being tipped.									
Control measures	Operators are responsible to obey all instructions and warning signs regarding keeping himself and others away from the machine while in use. If tipping items such as glass, metal or liquids, glasses and gloves should be worn.									
Comments										

<b>Crushing due to machine falling over</b>										
Operator	LO:	2	FE:	4	DPH:	8	NP:	1	Risk Factor:	64
	Relatively low risk as the Multi-Tip is very stable, and the bin's centre of gravity remains well within the machine's footprint throughout the tipping cycle.									
Other persons	LO:	2	FE:	1	DPH:	8	NP:	1	Risk Factor:	16
	As above.									
Control measures	Do not operate on uneven ground, or ground with a slope of more than 1:12. Never attempt to empty liquids from closed-top drums.									
Comments										
<b>Electrocution or electric shock</b>										
Operator	LO:	0.5	FE:	4	DPH:	15	NP:	1	Risk Factor:	30
	Some risk is always present with mains leads.									
Other persons	LO:	0.5	FE:	4	DPH:	15	NP:	1	Risk Factor:	30
	As above.									
Control measures	Fit a Residual Current Device (RCD) to all power sockets. Check all leads frequently and repair or replace if damaged. All leads should be checked and tagged by a registered electrician at regular intervals.									
Comments	Mains-powered Multi-Tips are earthed and comply with AS60204.1. The charger on battery-powered Multi-Tips is double-insulated.									
<b>Contamination from tipping toxic powder and liquid</b>										
Operator	LO:	2	FE:	4	DPH:	1	NP:	1	Risk Factor:	8
	Great care should be taken when tipping powder or liquids. If the product could cause any harm whatsoever to the operator or to any other person, ensure all persons are well protected.									
Other persons	LO:	2	FE:	4	DPH:	1	NP:	1	Risk Factor:	8
	As above.									
Control measures	The operator must wear appropriate protective equipment, and ensure that all other persons are well clear of the area. Powder should only be tipped when there is no wind, and/or a wind shield should be installed.									
Comments	Substances of a toxicity that cannot be protected against with PPE should not be emptied with a Multi-Tip. Alternative methods should be used.									
<b>Damage to skin when used in extreme weather conditions</b>										
Operator	LO:	2	FE:	4	DPH:	1	NP:	1	Risk Factor:	8
	If the machine is to be used in extreme cold or heat, the operator must wear gloves and other suitable Personal Protective Equipment.									
Other persons	LO:	2	FE:	4	DPH:	1	NP:	1	Risk Factor:	8
	As above.									
Control measures	Operators must wear appropriate Personal Protective Equipment (PPE) when operating machinery in extreme weather conditions.									
Comments	See <a href="#">Section 2.8</a> for Multi-Tip environmental restrictions.									



**Site-specific hazard:**

Operator	LO:		FE:		DPH:		NP:		Risk Factor:	
Other persons	LO:		FE:		DPH:		NP:		Risk Factor:	
Control measures										
Comments										

**Site-specific hazard:**

Operator	LO:		FE:		DPH:		NP:		Risk Factor:	
Other persons	LO:		FE:		DPH:		NP:		Risk Factor:	
Control measures										
Comments										

**Site-specific hazard:**

Operator	LO:		FE:		DPH:		NP:		Risk Factor:	
Other persons	LO:		FE:		DPH:		NP:		Risk Factor:	
Control measures										
Comments										

**Site-specific hazard:**

Operator	LO:		FE:		DPH:		NP:		Risk Factor:	
Other persons	LO:		FE:		DPH:		NP:		Risk Factor:	
Control measures										
Comments										



Site-specific hazard:										
Operator	LO:		FE:		DPH:		NP:		Risk Factor:	
Other persons	LO:		FE:		DPH:		NP:		Risk Factor:	
Control measures										
Comments										
Site-specific hazard:										
Operator	LO:		FE:		DPH:		NP:		Risk Factor:	
Other persons	LO:		FE:		DPH:		NP:		Risk Factor:	
Control measures										
Comments										

### 3.4.3 Residual Hazards

As with all powered industrial equipment, some 'residual hazards' may be present despite any guarding or safety measures implemented by the manufacturer.

The machinery owner has a legal responsibility to identify and assess these residual hazards, and to take **all reasonable precautions** to eliminate, isolate, or minimize them. Such precautions may include any or all of the following:

- ⚠ Taking steps to monitor and enforce the training of operators.
- ⚠ Design and implementation of Standard Operating Procedures.
- ⚠ Using disciplinary measures to ensure the Standard Operating Procedures are followed.
- ⚠ Posting signage, floor marking, or other warnings as deemed appropriate.
- ⚠ Taking steps to develop a culture of safety and open communication among staff.

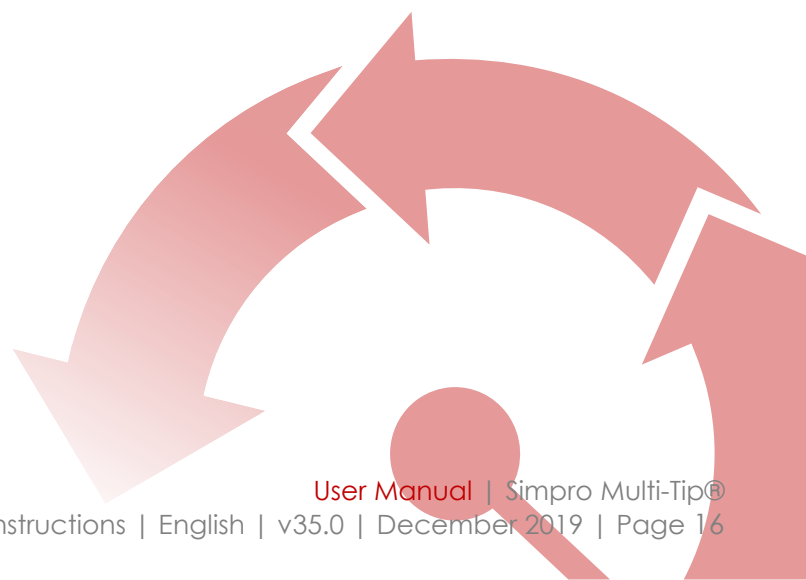

## 3.5 Safety Norms

The following safety norms must be observed for the safe use of a Multi-Tip bin lifter.

Only trained and authorised personnel are permitted to use the machine.

Operators must read and obey the instructions displayed on the machine.

Never operate the machine on soft ground, or ground with a slope ratio greater than 1:12.

Never operate the machine on the edge of a raised dock or platform.

Never operate machine with any covers or guards removed.

Never attempt to empty the contents of closed-top drums, unless the machine is securely bolted down.

All persons other than the operator must keep at least two metres clear while the machine is in use.

Always keep hands and feet well clear of the bin and cradle when operating.

Do not place limbs, feet or foreign objects under the side guards or safety door.

Do not attempt to empty over-filled or overflowing bins.

Before connecting machine to mains supply, ensure voltage and frequency correspond with that listed on the rating plate.

Do not use an extension lead longer than 15 metres to connect the machine to mains power.

Do not operate if power lead, insulation or power plugs are damaged.

Do not connect a damp power plug or socket.

Ensure the power supply socket is fitted with a residual current device.

Ensure there is complete continuity between the machine and an effective earthing system which complies with local and national regulations. The manufacturer cannot be held liable for the consequences of an inadequate earthing system.

## 4. Operating Instructions

### 4.1 Before operation

Before operating a Multi-Tip bin lifter, check the following points to ensure that the machine is stable and safe to use.

1. The machine is on level hard ground, with a slope of 1:12 or less.
2. All covers and safety guards are in place.
3. The wheel brakes are applied.
4. All personnel other than the operator are well clear of the machine.
5. The cradle is fully lowered.
6. The key is inserted and turned to the ON position.
7. The battery indicator shows an acceptable level of charge.

### 4.2 Emplacing and removing bins

**⚠ All personnel using the machine must know how to correctly emplace and remove bins from the machine. Bins that are not correctly emplaced may come loose and damage the machine while being lifted, or fall out when inverted.**

The bin cradle is designed to allow bins to be emplaced and removed easily, while also holding them securely throughout the lifting and tipping cycle. A range of different cradles may be installed, depending on the types of bin that the machine needs to empty. Use the following table to identify the correct instructions for your machine.

#### 4.2.1 Cradle identification

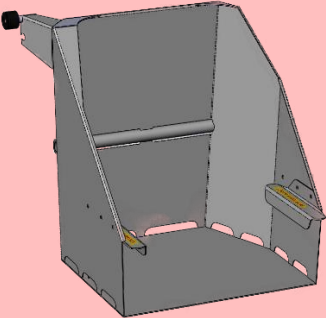
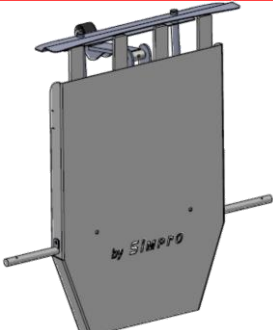
Cradle Type	Primary Usage	Bin Compatibility	Cradle Image	Refer
EN840 Base-lift Cradle (standard)	Waste management applications in all regions except North America	EN840-compliant Wheelie Bins		<a href="#">4.2.2</a>
EN840 Comb-lift Cradle	Waste management applications in UK and Europe	EN840-compliant Wheelie Bins		<a href="#">4.2.3</a>

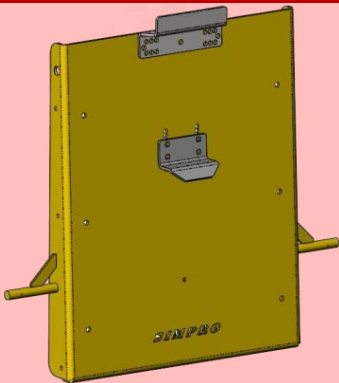
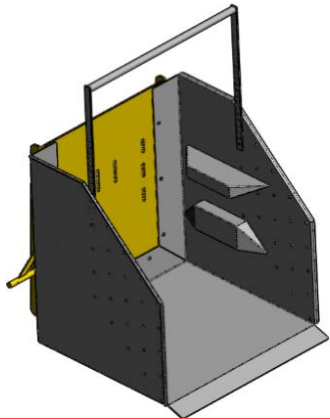
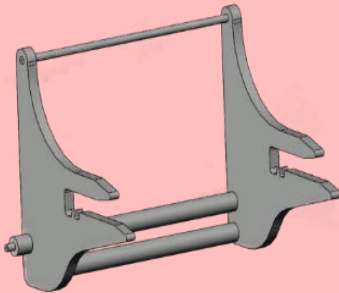
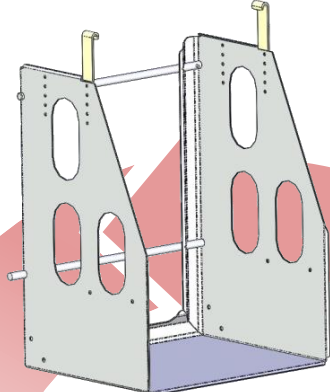
Cradle Type	Primary Usage	Bin Compatibility	Cradle Image	Refer
ANSI Bar-lift Cradle	Waste management applications in North America	ANSI Z245.60 Type-B compliant Trash Carts	<ul style="list-style-type: none"> <li>- 32 gal</li> <li>- 48 gal</li> <li>- 64 gal</li> <li>- 96 gal</li> </ul> 	<a href="#">4.2.4</a>
ANSI Bar-lift Cradle with base	General applications in North America	BRUTE® Bins 205L Drums Plastic Tubs Customs Bins	<ul style="list-style-type: none"> <li>- 10 gal</li> <li>- 20 gal</li> <li>- 28 gal</li> <li>- 32 gal</li> <li>- 40 gal</li> <li>- 44 gal</li> <li>- 55 gal</li> </ul> 	<a href="#">4.2.5</a>
DIN9797 120L Trunnion-lift Cradle	Food processing and hygiene-critical applications	DIN9797-compliant Eurobins	- 120L	
DIN9797 200L Trunnion-lift Cradle			- 200L - 300L	
FoodCap® 180L Trunnion-lift Cradle		Foodcap® Capsules	- 180L	
Combi-Cradle	General and custom applications	BRUTE® Bins 205L Drums Plastic Tubs Customs Bins		<a href="#">4.2.7</a>
Custom Cradle	Custom applications	Custom bins		

## 4.2.2 EN840 Base-lift Cradle (standard)

### 4.2.2.1 Emplacing bins

Place the wheelie bin onto the cradle. For full-size 240L bins, both wheels should be positioned into a catch (on either side of the cradle). For smaller bins such as 60L, 80L, 120L and 140L, only the left-hand wheel needs be positioned into a catch. Once the bin is correctly emplaced, walk to the control panel.

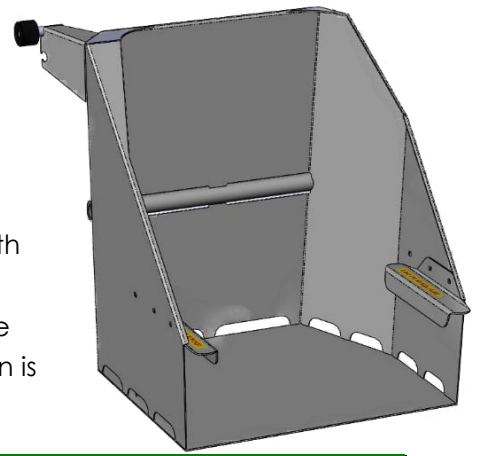

- ⚠ The wheel catches are designed to work with standard EN840 wheelie bins from leading brands such as Europlast, Sulo, ESE, Weber, Craemer, OnePlastics and Trident.
- ⚠ Some smaller bin manufacturers use axles of different lengths. If the distance between the wheels is slightly too large or small, the wheels may jam against the catches, preventing a secure emplacement. Should this occur, simply unbolt and remove the right-hand wheel catch. All bins can be securely held by the left-hand catch only.
- ⚠ Some smaller bin manufacturers use tyres which are too wide to fit inside the wheel catches. Should this issue occur, simply insert additional packers (flat washers) onto the wheel catch mounting bolts, to increase the spacing as needed.

### 4.2.2.2 Removing bins

Pull the wheelie bin gently out of the cradle, using the grab-handles provided.

## 4.2.3 EN840 Comb-lift Cradle

### 4.2.3.1 Emplacing bins

Place the wheelie bin into the machine, positioned centrally against the cradle backplate. Take care that the lifting teeth are properly hooked into the bin combing; smaller bins such as 60L and 80L may need to be tilted or lifted slightly to ensure a proper 'catch'. Once the bin is correctly emplaced, walk to the control panel.

### 4.2.3.2 Removing bins

Pull the wheelie bin gently out of the machine, using the grab-handles provided. Smaller bins may need to be tilted or lifted slightly to detach them from the lifting teeth.

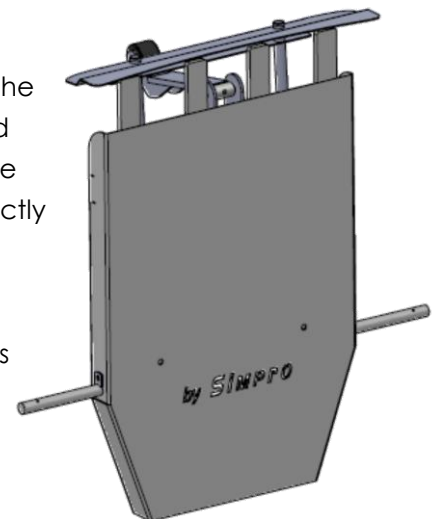

## 4.2.4 ANSI Bar-lift Cradle

### 4.2.4.1 Emplacing bins

Place the trash cart into the machine, positioned centrally against the cradle backplate. Take care that the lifting catches are properly hooked into the front of the cart; some carts may need to be tilted or shaken slightly to ensure a proper 'catch'. Once the cart is correctly emplaced, walk to the control panel.

### 4.2.4.2 Removing bins

Pull the trash cart gently out of the machine, using the grab-handles provided. Some carts may need to be tilted or shaken slightly to detach them from the lifting catches.

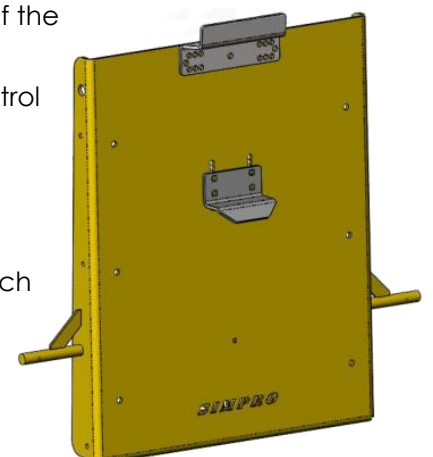

## 4.2.5 ANSI Bar-lift Cradle with base

### 4.2.5.1 Emplacing bins

Place the bin, drum or container onto the cradle, positioned centrally against the backplate. Once the bin is correctly emplaced, walk to the control panel.

- ⚠ When moving heavy non-wheeled containers it is recommended to use a specialised dolly, hand truck or forklift attachment.
- ⚠ The catch arm(s) should be positioned to hold the top edges of the bin, with a maximum free travel of 25mm (1 inch). The arm(s) can be unbolted and repositioned to allow emptying bins of many different sizes.

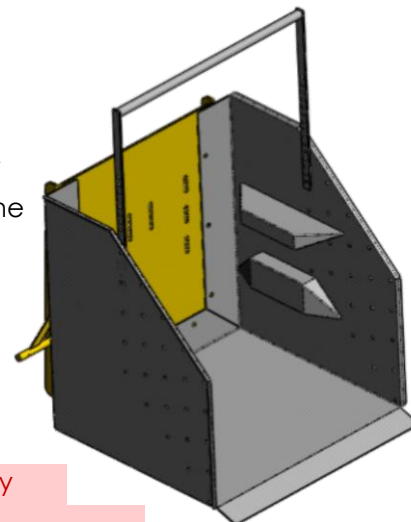

### 4.2.5.2 Removing bins

Take hold of the upper edge of the bin, drum or container, and pull it gently out of the cradle.

## 4.2.6 Trunnion-lift Cradle (DIN9797 Eurobins & Foodcap®)

### 4.2.6.1 Emplacing bins

Wheel the bin into the cradle, positioned centrally, until it is firmly against the stop-buffers. Take care that both trunnions are properly seated in the lifting arms; some bins may need to be tilted or shaken slightly to ensure a proper 'catch'. Once the bin is correctly emplaced, walk to the control panel.

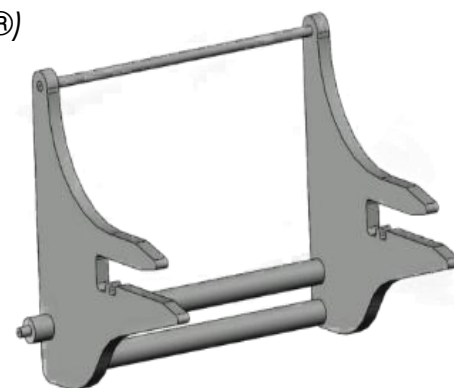

### 4.2.6.2 Removing bins

Take hold the grab-handle on the rear of the Eurobin (or the upper edge of the Foodcap® capsule), and pull it gently out of the cradle.

## 4.2.7 Combi-Cradle and Custom Cradle

### 4.2.7.1 Emplacing bins

Place the bin, drum or container onto the cradle, positioned centrally against the backplate. Once the bin is correctly emplaced, walk to the control panel.

- ⚠ When moving heavy non-wheeled containers it is recommended to use a specialised dolly, hand truck or forklift attachment.
- ⚠ The catch arm(s) should be positioned to hold the top edges of the bin, with a maximum free travel of 25mm (1 inch). The arm(s) can be unbolted and repositioned to allow emptying bins of many different sizes.

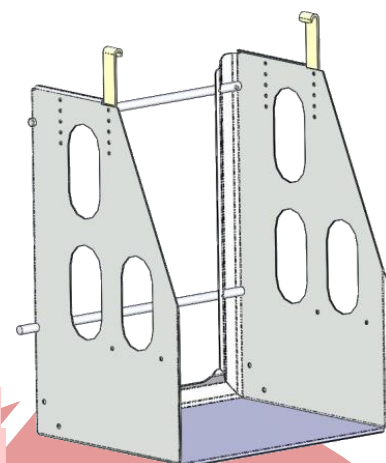

### 4.2.7.2 Removing bins

Take hold of the upper edge of the bin, drum or container, and pull it gently out of the cradle.

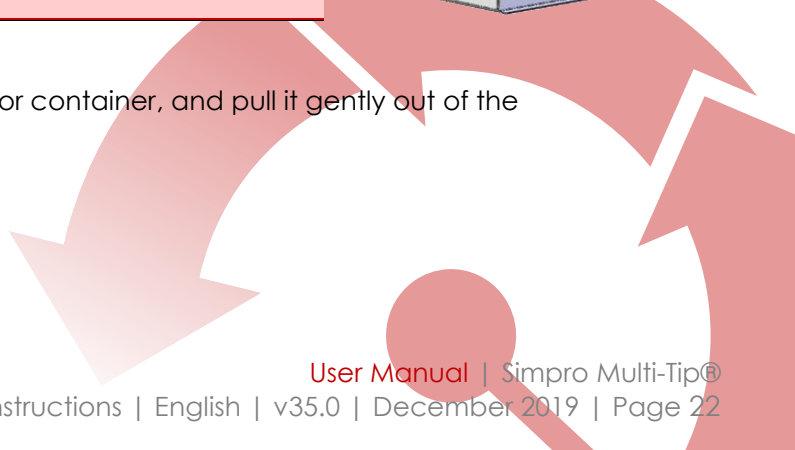



## 4.3 Operation of controls

- ⚠️ All personnel using the machine must know how to correctly operate the controls. Incorrect operation may result in a safety hazard or damage to the machine.
- ⚠️ A small number of machines have customised or non-standard controls, which are provided with their own operating instructions in a separate document.

The Multi-Tip controls are designed to allow simple, safe and fast operation of the electro-hydraulic systems.

1. Before operation, check that the machine is stable and safe to use as per [Section 4.1](#).
2. Place the full bin on the cradle, taking care that it is properly positioned as per [Section 4.2](#).
3. Standing at the operator controls, simultaneously press the SAFETY button under the left side of the shroud, and the RAISE button under the right side of the shroud. Hold both buttons down until the bin reaches the inverted position, then release.
4. Wait for the contents of the bin to empty.
5. Simultaneously press the SAFETY button and the LOWER button, holding both down until the cradle rests on the ground.
6. Remove the empty bin as per [Section 4.2](#).
7. Repeat from step 2) as required.





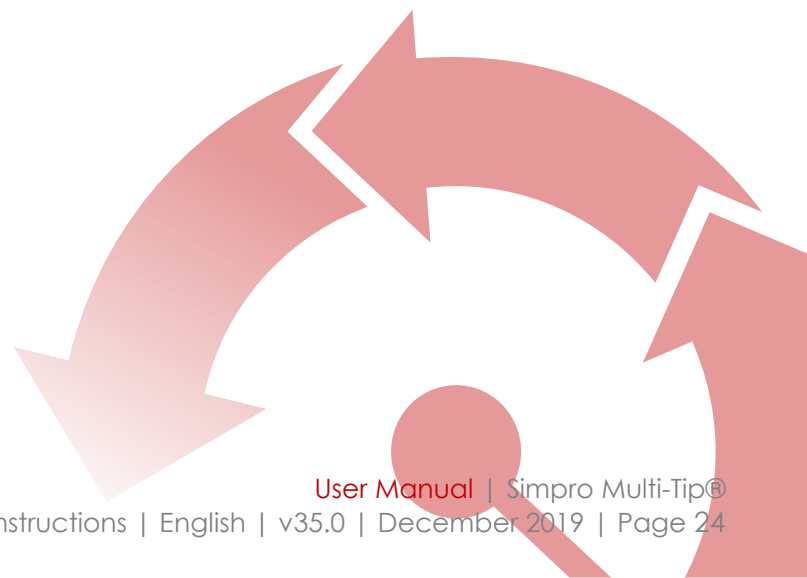





## 5. Care and Maintenance

The Multi-Tip is designed to give many years of service with minimal maintenance. In the event a fault or malfunction does occur, refer to the [Quick Trouble Shooting Guide in Section 5.1](#) before contacting your agent for service. A Service Manual giving testing and repair instructions is available on request from Simpro.

-  Contact your Simpro agent if repair or service work is required.
-  All repair and service work must be carried out by qualified personnel.
-  Replacement parts must be supplied by Simpro or an authorized Simpro agent, and must be of the same design and specification as the original parts.
-  A detailed Service Manual giving specific testing and repair instructions is available on request from Simpro.

### 5.1 Quick Troubleshooting Guide

Please refer to the Quick Trouble Shooting Guide below before requesting technical support.

Problem	Possible Causes	Remedy	Reference
The machine will not lift bins, and the motor does not run	Flat Battery	Battery should be charged if the indicator shows less than 12.2 volts.	<a href="#">5.4.3</a>
	Blown fuse, faulty power lead or plug	Check and rectify. The fuse may blow if the machine is used with a flat battery.	<a href="#">5.4.8</a>
	Faulty switch or wiring	Check and rectify; contact your agent for replacement parts if necessary	
	Faulty raise relay or contactor	The machine should emit a 'click' sound when the SAFETY and RAISE buttons are pressed – if not, check the motor relay and replace if necessary	
The machine will not lift bins, although the motor runs	Bin too heavy	Remove material to reduce bin weight.	<a href="#">5.3.1.1</a>
	Pressure-relief valve set too low	Contact Simpro for instructions on how to adjust the pressure-relief valve	<a href="#">5.7.2.2</a>
	Motor running wrong direction (3-phase)	Swap phase wires in the power plug	<a href="#">5.5.1</a>
Cradle will not come down from the fully raised position	Mast slider frame jamming in mast	Lightly lubricant inside of mast, slider block and rollers with silicone spray	<a href="#">5.3.2</a>
	Lift ram jamming	Contact your agent for instructions	<a href="#">5.3.2</a>
	Faulty switch, wiring, or lowering valve	The machine should emit a 'click' sound when the SAFETY and LOWER buttons are pressed – if not, check the switch, wiring and lowering valve	<a href="#">5.3.2</a>
Cradle jams part way down	Mast bent or damaged	Check and straighten; contact your agent for replacement parts if necessary	<a href="#">5.3.2</a>
	Tip guide flap sticking or damaged	Check and rectify; contact your agent for replacement parts if necessary	<a href="#">5.3.2</a>

## 5.2 Cleaning

The machine should be cleaned with a low-pressure water jet, a microfiber cloth and a mild cleaning solution. Cleaning should only be carried out with the cradle lowered.

 Do not clean the Multi-Tip with a high-pressure water jet or waterblaster.

 For IP ratings of the machine and various subcomponents refer to [Section 2.9](#).

## 5.3 Cradle jams

Occasionally the bin cradle may become jammed at some point in the tipping cycle. This is usually a minor issue which may be easily rectified.

- 1 The cradle is not powered down – it is lowered by gravity alone.
- 2 Refer to [Section 5.7](#) for details and schematics of the hydraulic system.

### 5.3.1 Cradle jams while raising

If the cradle jams while raising the cause may be either an overweight bin, or a mechanical fault, such as a bent tipping guide or misaligned roller.

#### 5.3.1.1 Overweight bin

1. Lower the cradle to ground level and remove the bin.
2. Manually remove some material from the bin, then try again.

 If the pressure-relief valve is adjusted incorrectly, the cradle may stall even when lifting bins that are within the rated capacity of the machine. Adjustment of the pressure-relief valve may only be carried out by a suitably qualified technician, with prior authorization from Simpro.

#### 5.3.1.2 Mechanical fault

1. If possible, lower the cradle to ground level and remove the bin.
2. Attempt to visually identify the cause of the jamming. The most likely causes are:
  - a. The lifting chain may have derailed from the guide at the top of the mast.
  - b. The mast may have been bent or damaged.
  - c. Lack of lubrication on the follower roller, or the main cradle axle
  - d. The roller arm may be pressing against the tipping guide, due to the cradle sitting out of level or being incorrectly adjusted.
3. With the cradle lowered, rectify the problem by straightening and/or realigning the mechanical components as required. If the mast is bent, you may need to contact your agent for support.
4. Run the machine through several full cycles to ensure the problem has been resolved.

### 5.3.2 Cradle jams while lowering

If the cradle jams on the way down, or has jammed on the way up but will not come down, it may be due to a hydraulic, electrical, or mechanical fault.

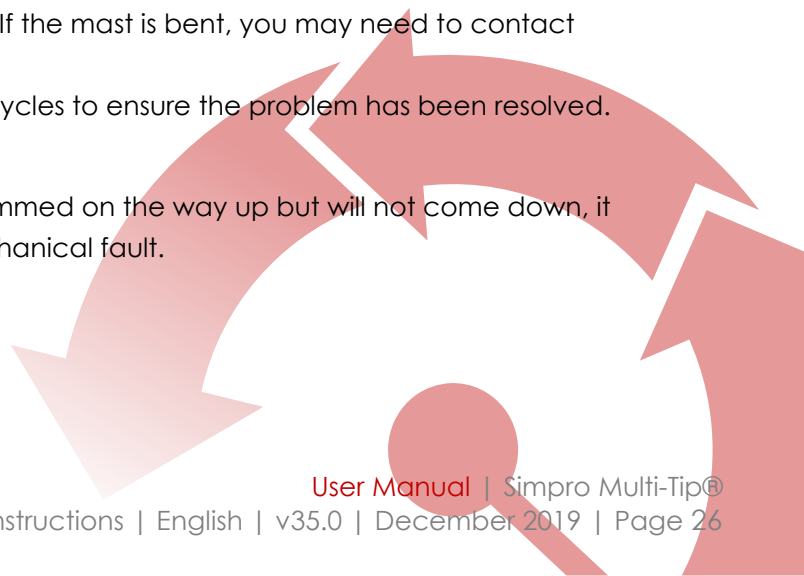

### 5.3.2.1 Hydraulic or electrical fault

When the SAFETY and LOWER buttons are pressed simultaneously, the lowering valve should emit a 'click' sound as it opens. If it does not, the problem may be either a hydraulic or electrical fault.

1. Manually remove the bin if it is safe to do so.
2. Use a forklift or hoist to physically support the cradle in position.

**⚠ Never place any part of your body underneath the cradle unless it is securely supported.**

3. Remove the powerpack cover.
4. Check that the lowering valve coil is receiving an electrical signal. An LED lamp should glow on the coil plug when the SAFETY and LOWER buttons are pressed simultaneously. If it does not, check the wiring.
5. If the coil is receiving an electrical signal but not opening, it may need to be cleaned:
  - a. Remove the coil from the valve stem.
  - b. Unscrew the lowering valve cartridge.
  - c. Clean the cartridge with compressed air.
  - d. Replace the lowering valve components by reversing this procedure.
6. Detach the forklift/hoist from the cradle, and test to see if the cradle lowers correctly.
7. Run the machine through several full cycles to ensure the problem has been properly resolved. If the lowering valve is still not operating correctly, it may need to be replaced – contact your agent.

### 5.3.2.2 Mechanical fault

If the lowering valve is operating correctly (emits a 'click' sound when the SAFETY and LOWER buttons are pressed), the problem may be a mechanical fault.

1. Manually remove the bin if it is safe to do so.
2. Use a forklift or hoist to physically support the cradle in position.

**⚠ Never place any part of your body underneath the cradle unless it is securely supported.**

3. Attempt to visually identify the cause of the jamming. The most likely causes are:
  - a. The lifting chain may have derailed from the guide at the top of the mast.
  - b. The mast may have been bent or damaged.
  - c. Lack of lubrication on the follower roller, or the main cradle axle
  - d. The roller arm may be pressing against the tipping guide, due to the cradle sitting out of level or being incorrectly adjusted.
4. Rectify the problem by straightening and/or realigning the mechanical components as required. If the mast is bent, you may need to contact your agent for support.
5. Detach the forklift/hoist from the cradle, and test to see if the cradle lowers correctly.
6. Run the machine through several full cycles to ensure the problem has been properly resolved.

## 5.4 Electrical System (battery)

**⚠️ If you do not operate a battery-powered machine, please disregard this section.**

Standard battery-powered machines are fitted with a single deep-cycle sealed gel battery, a digital smart charger, and a series-wound 12VDC motor. The control voltage is 12VDC.

The motor only runs when the RAISE button is pressed; the cradle is lowered by gravity alone. As a rule, one full charge is sufficient to empty 3 tonnes of material, but this is dependent on the tipping height and the condition of the batteries.

### 5.4.1 Localisation

The digital smart charger fitted to battery machines automatically adapts to a range of different input voltages and phase frequencies. This means the machine can be charged using standard 1-phase mains power in almost any country around the world. A power plug adapter may be required in some cases.

### 5.4.2 Voltmeter

Battery machines are fitted with a digital voltmeter on the control panel, which is used to indicate the charge level of the batteries. As shown on the markings, **when the voltmeter reads less than 12 volts the batteries are flat.** The machine should not be used and should be placed on charge as soon as possible.

**⚠️ Because the voltage will fluctuate when the machine is operated, the charge level should be checked while the machine is at rest.**

**⚠️ Attempting to operate a machine with flat batteries may cause the overload fuse on the battery cable to blow (see [Section 5.4.8](#)). It may also damage the batteries.**

### 5.4.3 Battery charging

To recharge the battery, simply **connect the supplied IEC power lead into the socket on the side of the machine, and into a standard 1-phase power outlet.**

A full charge normally takes about 5 hours, and the machine can be used while on charge.

- ⚠️ The onboard smart charger automatically adapts to different input currents, manages the charging cycle to maximise battery life, and prevents overcharging.**
- ⚠️ The charger delivers enough power to empty one bin in about 5 minutes, which means that a battery-powered machine left permanently on charge can normally be used in place of a 1-phase mains-powered machine (see [Section 2.5](#)).**
- ⚠️ On some older machines, the batteries will not charge if the battery isolator switch is turned OFF (see [Section 5.4.7](#)).**



#### 5.4.4 Batteries and battery care

Standard battery machines are fitted with a single 12V 21Ah deep-cycle sealed gel battery which delivers 12VDC (nominal) to the motor and control systems.

The battery is maintenance-free and designed to last more than five years. However, battery life is dependent on several factors, including the number of charge/discharge cycles, the depth of discharge and environmental conditions.

##### 5.4.4.1 Maximising battery life

To maximize the battery life on your machine, observe the following rules.

- Place the battery on charge every night (or permanently).
- Do not allow the machine to sit with a flat battery for more than 24 hours.
- Do not operate the machine when the battery is flat (reading less than 12.2V).

 The battery is supplied with a 12-month manufacturer's warranty, separate from the warranty on the rest of the machine.

#### 5.4.5 Smart charger

Battery machines are fitted with a digital smart charger which accepts any 1-phase power input between 84-264 Volts and 50-60 Hertz. The maximum current draw is 3 Amps.

The charger delivers output of up to 10 Amps continuous current at 13.6VDC, for a maximum power output of 136 Watts.

 The charger is in an enclosed plastic case and is protected against short-circuit, current overload, over-voltage and over-temperature.

#### 5.4.6 IEC power lead

The Multi-Tip uses an IEC C13 power lead, which connects to the IEC C14 socket on the side of the machine. IEC leads are used for many household appliances and are widely available from electronics stores. They are sometimes known as 'kettle leads'.

#### 5.4.7 Isolator switch

Battery machines are fitted with an isolator switch adjacent to the charging socket. This switch disconnects battery from the electrical systems, and should be turned OFF if the machine is to be placed in storage, or if the powerpack cover needs to be removed.

 On some older models, the battery will not charge if the isolator switch is turned OFF.

#### 5.4.8 Overload fuse

Battery machines are fitted with an overload fuse to protect the electrical system from excessive current draw. The fuse is a standard automotive MAXI blade-fuse, grey in colour, with a **120 Amp rating**. Replacements are available from Simpro (part 0790050107) or any automotive parts retailer.

 Because the current draw of the motor increases as the battery voltage drops, operating the machine with a flat battery may cause the overload fuse to blow.

### 5.4.9 Solar panel

**⚠️ If you do not operate a machine with a solar panel, please disregard this section.**

Battery machines may be fitted with a solar panel kit to allow operation in locations without mains power. The 80W/12V monocrystalline solar panel (dimensions 930x673x35mm) is mounted on an adjustable steel bracket at the top of the mast, and delivers power to the battery via a digital regulator.

As per [Section 2.5](#), in ideal conditions the solar panel provides enough power to dump about 2,000kg of material each day, which is equivalent to about 20 full 240L wheelie bins. There are many factors affecting this figure, including the season, the amount of sunlight available, cloud cover, panel alignment and cleanliness, and the condition of the battery.

**⚠️ To deliver maximum power the solar panel must be correctly aligned, clean, and exposed to direct sunlight throughout the day.**

#### 5.4.9.1 Solar panel alignment

The solar panel is mounted on an adjustable steel bracket with one axis of movement. To deliver maximum power, the panel should be aligned to cast the largest-possible shadow when the sun is at its highest point in the sky. However, because the bracket has only one axis of movement, the orientation of the machine itself affects the optimum panel alignment.

Use the following guidelines to align the solar panel:

1. Ideally, orient the machine so that adjustment arc of the panel mounting bracket runs from North to South.
2. If the adjustment arc cannot be oriented North-South, the panel should be angled at 0° degrees (vertical). While this is suitable close to the equator, it will progressively reduce the power output at latitudes beyond  $\pm 20^\circ$  degrees.
3. With the machine in its long-term position, **tilt the panel towards the equator** by the same number of degrees as the machine's geographic latitude.
4. If required, a further 5-10% increase in output can be achieved by tuning the panel alignment for the Summer and Winter months:
  - a. At the beginning of Spring, reduce the angle of the panel so it is equal to the machine's geographic latitude **less 15° degrees**.
  - b. At the beginning of Autumn (Fall), increase the angle of the panel so it is equal to the machine's geographic latitude **plus 15° degrees**.

**⚠️ The panel angles referred to above are measured in degrees of arc from vertical.**

**⚠️ Without correct adjustment the solar panel may deliver as little as 20% of the theoretical maximum output. Correctly adjusting the panel when the machine is installed can increase this figure to ~70%, and adjustment twice a year can increase output to ~75% of the theoretical maximum.**

#### 5.4.9.2 Solar panel cleaning

The solar panel should be cleaned every six months, using a microfiber cloth or damp rag.

**⚠️ Use appropriate height-safety equipment when adjusting or cleaning the solar panel.**



## 5.5 Electrical System (3-phase mains)

- ⚠️ If you do not operate a 3-phase mains machine, please disregard this section.
- ⚠️ The 3-phase mains specification is recommended for high-intensity applications.

Machines powered by 3-phase mains electricity are generally the same as other models, but are fitted with a 3-phase 2-pole electric motor driving the hydraulic pump. The control voltage is 24VDC. In some countries an electronic VSD is also fitted in order to provide suitable current to the motor.

The motor only runs when the RAISE button is pressed; the cradle is lowered by gravity alone.

### 5.5.1 Localisation

The exact specifications of 3-phase machines differ depending on the standard voltage and frequency of 3-phase mains power in the country for which the machine was designed.

In locations where 3-phase/~400VAC/50Hz power is standard (AU, NZ, UK, EU, most of Asia) the motor is driven directly by the mains current in 'delta configuration'. In locations where different voltages and frequencies are common (USA, Canada, South and Central America) an electronic Variable Speed Drive (VSD) is fitted, which modulates the local mains supply and outputs 3-phase/400VAC/50Hz current to the motor in 'star configuration'.

A list of 3-phase power standards used in different countries and territories may be viewed at this web address: <https://www.worldstandards.eu/three-phase-electric-power/>.

- ⚠️ Connecting the machine to a power supply for which it was not designed may cause serious damage. Consult an electrician if you are unsure.

- ⚠️ If the phase wires in the wall socket or extension lead are configured incorrectly, the 3-phase motor may turn in the reverse direction. Although this does not damage the machine, the cradle will not lift. To change the motor direction, swap over any two of the phase wires in the power plug.

### 5.5.2 Transformer

3-phase machines are fitted with a transformer which outputs 24VDC current to the control systems. The transformer input voltage and frequency depend on the standard 3-phase mains power in the country for which the machine was designed.



## 5.6 Electrical System (1-phase mains)

 If you do not operate a 1-phase mains machine, please disregard this section.

Machines powered by 1-phase mains electricity are generally the same as other models, but are fitted with an electronic Variable Speed Drive (VSD), which operates a 3-phase 2-pole electric motor driving the hydraulic pump. The control voltage is 24VDC.

The motor only runs when the RAISE button is pressed; the cradle is lowered by gravity alone.

### 5.6.1 Localisation

The exact specifications of 1-phase machines differ depending on the standard voltage and frequency of 1-phase mains power in the country for which the machine was designed. Both the transformer ([Section 5.6.2](#)) and the VSD ([Section 5.6.3](#)) are specified to suit local norms.

A list of 1-phase power standards used in different countries and territories may be viewed at this web address: <https://www.worldstandards.eu/electricity/plug-voltage-by-country/>.

 Connecting the machine to a power supply for which it was not designed may cause serious damage. Consult an electrician if you are unsure.

### 5.6.2 Transformer

1-phase machines are fitted with a transformer which outputs 24vdc current to the control systems. The transformer input voltage and frequency depend on the standard 1-phase mains power in the country for which the machine was designed.

### 5.6.3 Variable Speed Drive

1-phase machines are fitted with an electronic Variable Speed Drive (VSD), which outputs 3-phase/400VAC/50Hz current to the motor in 'star configuration'. The VSD input voltage and frequency depend on the standard 1-phase mains power in the country for which the machine was designed.

The VSD has many parameters that can be set to suit specific applications. They can be modified or calibrated by a PC that has the appropriate program and cable drivers loaded.

 A joystick controller can optionally be supplied with the VSD, permitting infinitely-variable control over the cradle lifting speed.

 Residual voltages may be retained in the VSD inverter after it has been disconnected from the power supply. Use extreme caution when servicing electrical components.

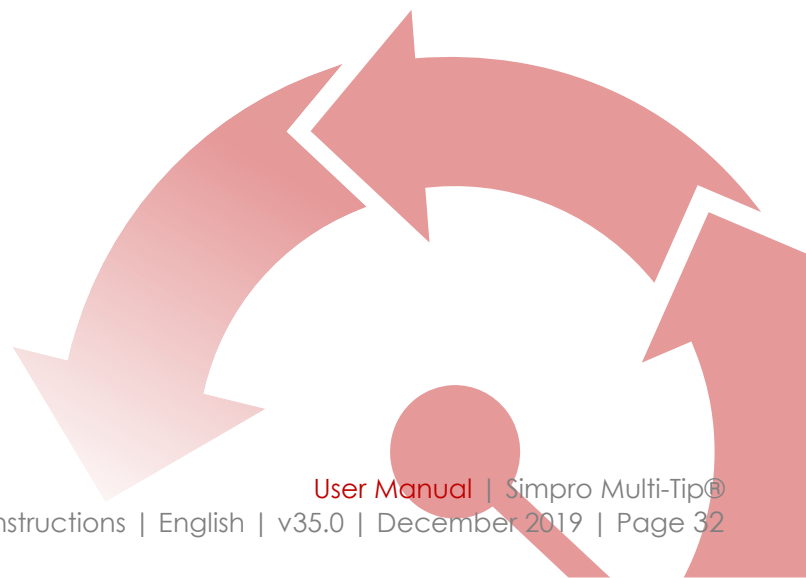

## 5.7 Hydraulic System

### 5.7.1 Powerpack

The hydraulic powerpack is supplied as a complete unit. The motor, pump, oil tank, and all control valves are mounted into the centre manifold.

### 5.7.2 Control valves

The hydraulic system has four primary control valves:

#### 5.7.2.1 Check valve

This is a one-way valve which prevents oil from flowing back through the pump when the motor is stopped.

#### 5.7.2.2 Pressure-relief valve

This is a spring-loaded valve which allows oil to flow back into the reservoir when the hydraulic pressure exceeds its rated limit – usually from lifting an overweight bin, or from operating the machine when the cradle is already at the top of the cycle.

#### 5.7.2.3 Lowering valve

This is a solenoid-operated valve which opens when the LOWER button is pressed and allows oil to flow back to the reservoir, lowering the cradle.

#### 5.7.2.4 Lowering-speed valve

This is a pressure-compensating valve which limits the maximum flow rate of oil passing back to the reservoir through the lowering valve – thus regulating the descent speed of the cradle (regardless of the weight of the bin).

### 5.7.3 Lift ram

The lift ram is a single-acting displacement type, very robust and reliable, but easy to maintain should the need arise. Hydraulic lines run from the powerpack to the lift ram.

### 5.7.4 Hydraulic fluid

The hydraulic system is designed to use mineral oil-based fluid with a viscosity grade of 22 (ISO VG22). Fluid with a higher viscosity grade may be used, but this will reduce the lowering speed of the cradle and increase the likelihood of jams.

The hydraulic fluid should have physical lubricating and chemical properties as specified by:

- Mineral Oil Based Hydraulic Fluids HL (DIN 51524 part 1)
- Mineral Oil Based Hydraulic Fluids HL P (DIN 51524 part 2)

 Ensure the cradle is completely lowered before replacing the hydraulic fluid.

 The hydraulic reservoir has markings showing the recommended fill level. Do not fill beyond this level unless specifically instructed by the manufacturer.

### 5.7.5 Maintenance

After every 12 months of operation the hydraulic fluid should be drained and replaced, as per specifications in [Section 5.7.4](#). The intake suction-filter and the lowering valve should also be removed and cleaned at this time.

 See [Section 7](#) for additional scheduled inspection and maintenance tasks.

5.7.6 Hydraulic system schematic

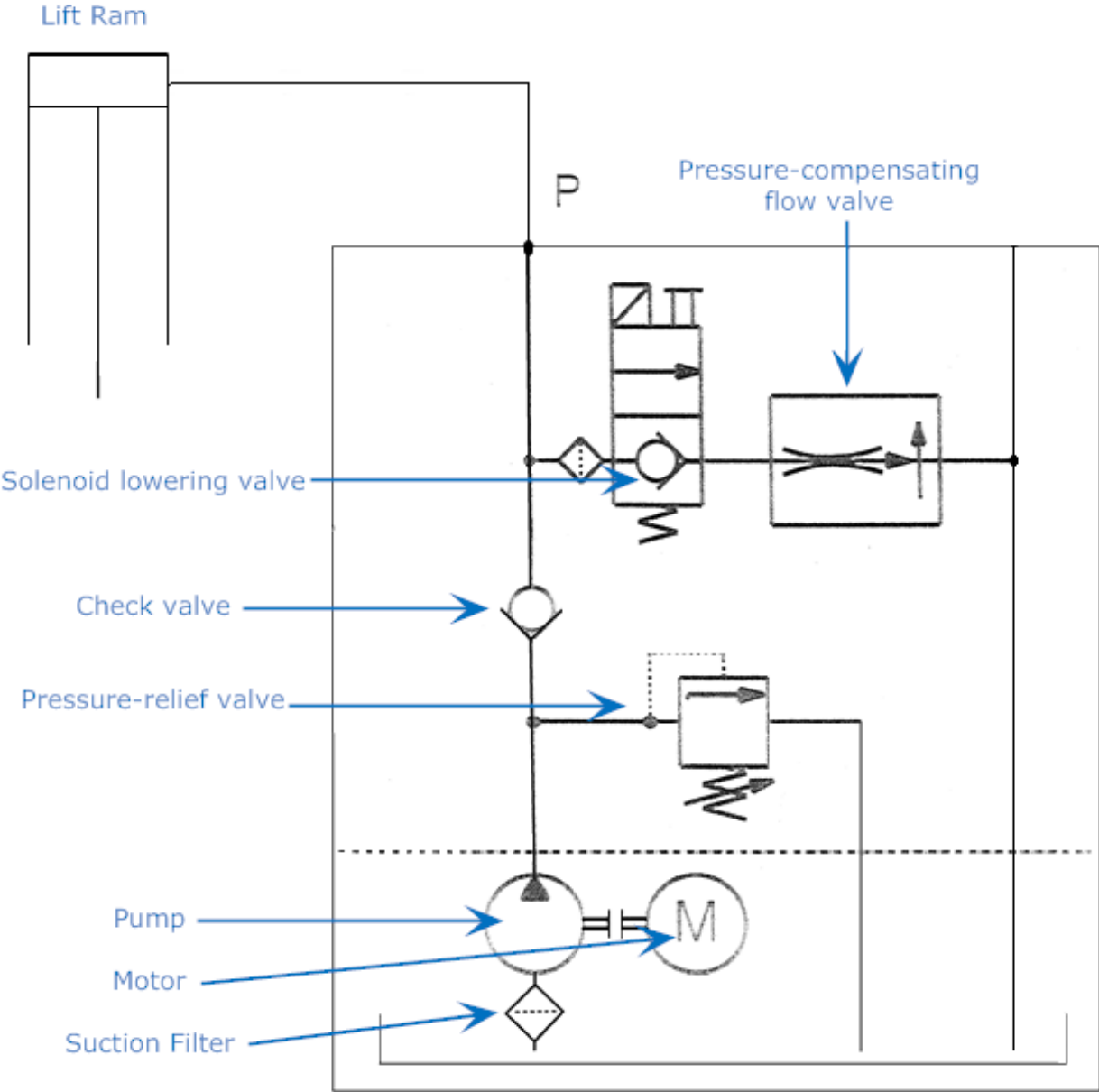

## 6. Assembly, Handling, Transport & Storage

### 6.1 Assembly

The Multi-Tip is usually delivered fully assembled. However, sometimes the machine may be delivered partially disassembled to minimise volume for shipping. Assembly instructions can be viewed at the following link: <https://support.simpro.world/help/multi-tip-assembly-guide>.

 In some cases, a sealed 'transit plug' is fitted to the hydraulic reservoir to prevent oil leaks during shipping. This must be replaced with the supplied 'breather plug' before the machine is operated, or the reservoir will be damaged.

### 6.2 Moving

When the machine is standing upright it may be easily moved on its castor wheels, using the large grab-handle provided. To ensure stability, the cradle should be positioned 100mm off the ground when moving.

 A small accessory is available from Simpro which enables a directional lock on the castor wheels. In some applications this makes the machine easier to manoeuvre.

 Extra care should be taken when moving the machine on sloping ground.

### 6.3 Lifting

If the machine needs to be lifted for any reason, carry out the following procedure:

1. Check that the lifting equipment is in good condition and rated to lift at least 250kg.
2. Affix a sling or chain to the lifting lug at the top of the mast.
3. Use one person to operate the lifting equipment, and at least one other person to hold the machine steady and watch for hazards.
4. Lift, move and lower the machine into position, ensuring it remains upright at all times.

 Standard Multi-Tip machines weigh between 150kg and 200kg. Always verify the weight of the machine on the rating plate, and check that the lifting equipment to be used has sufficient capacity.

 Never stand or reach underneath the machine while it is being lifted.

### 6.4 Transportation

Carry out the following procedure when the machine needs to be transported:

1. Apply both foot-brakes and turn the battery isolator switch to OFF.
2. If possible, use lifting equipment to place the machine upright on a wooden pallet, and securely strap it into place.
3. Use a 1-tonne forklift to load the pallet onto the truck deck.

4. Tie the machine into position using marked tie-down points and strops rated to at least 1000kg. Ensure it is fastened against lateral forces from any direction.

 To prevent oil leaks and damage to the guarding, do not lie the Multi-Tip over for transport.

## 6.5 Storage

If the machine is not to be used for a period of two months or more, it should be stored in a clean, dry place with good ventilation, at temperatures not below 0°C. Before placing the machine into storage, carry out the following procedure:

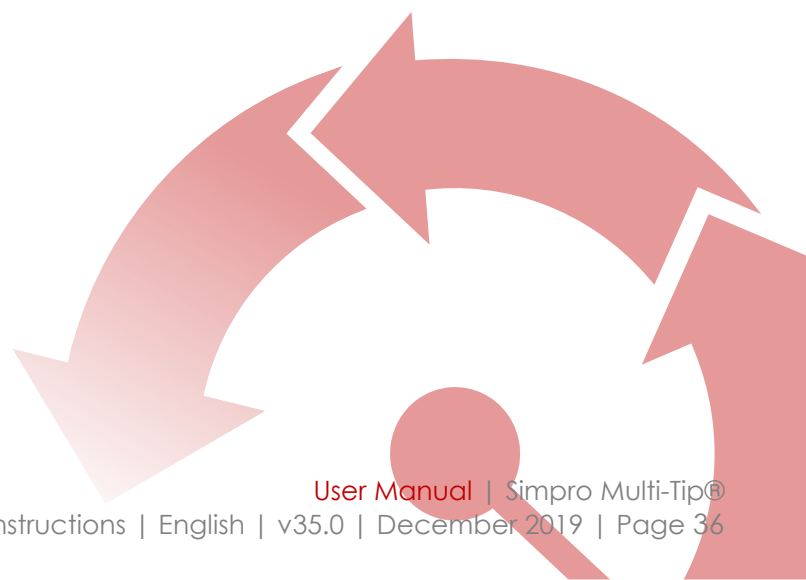

1. Clean the machine thoroughly.
2. Carry out several full tipping cycles, then lower the cradle to the ground.
3. Apply a thin layer of silicone lubricant to exposed surfaces of moving parts.
4. Charge the battery (if fitted) and apply a suitable lubricant to the electrical contacts.
5. Turn the battery isolator switch to the OFF position.
6. Remove the key and store in a safe location.



## 7. Safety Inspections

It is recommended to conduct regular scheduled inspections of the Multi-Tip. This helps to ensure operator safety and extend the service life of the machine.

The inspection schedule is divided into two parts: monthly inspections and annual inspections. The inspection procedures are described in the following pages, along with logs for recording the results.

-  Simpro strongly recommends that safety inspections are carried out according to the schedule described in this section.
-  Operators should immediately stop using the machine and request an inspection if any fault or abnormal operation is observed.

### 7.1 Pre-inspection checklist

1. Wear suitable Personal Protective Equipment (PPE), including safety boots and protective eyewear.
2. Ensure there are no ignition sources nearby.
3. Lower the cradle and remove bin.
4. Turn off the key switch and unplug the charging lead.
5. Remove the powerpack cover.
6. Clean the powerpack and electric circuitry with compressed air.
7. Always use height safety equipment when servicing elevated areas.

### 7.2 Monthly inspection

The following inspection should be carried out every month, and the results recorded in the log on the following page.

Monthly Inspection Checklist			
Category	No.	Item	Check
General	1	Entire machine	Visually inspect for dented or broken parts. Conduct a complete tipping cycle and check for any faults or abnormal behaviour.
Hydraulic systems	2	Hydraulic ram	Check there are no oil leaks.
	3	Oil reservoir	Check the level of hydraulic fluid and top up if necessary, in accordance with specs in <a href="#">Section 5.7.4</a> .
Safety systems	4	Dual-hand controls	Check that dual-hand controls operate correctly, and machine stops when the SAFETY button is released.
Mechanical systems	5	Inside mast	Lightly lubricate with silicone spray.
	6	Pivot roller	
	7	Cradle axle	
	8	Tipping guide flap	Check that flap is undamaged and moving freely.
	9	Castor wheels	Check that the castor wheels are running smoothly and both footbrakes are working correctly.

Date	Service Person	Location	Checks complete	Notes on repairs or maintenance required	Parts and materials used

## 7.3 Annual inspection

The following inspection should be carried out every 12 months, and the results recorded in the log on the following page.

Annual Inspection Checklist			
Category	No.	Item	Check
General	1	Entire machine	Visually inspect for dented or broken parts. Conduct a complete tipping cycle and check for any faults or abnormal behaviour.
Hydraulic systems	2	Hydraulic ram	Check there are no oil leaks.
	3	Oil reservoir	Drain and replace the hydraulic fluid, in accordance with the specifications in <a href="#">Section 5.7.4</a> . Clean the intake suction-filter.
	4	Lowering valve	Remove and clean.
Electrical systems	5	Power lead	Check that the power lead is in good condition, with no frayed or damaged insulation.
Safety systems	6	Dual-hand controls	Check that dual-hand controls operate correctly, and machine stops instantly when SAFETY button is released.
	7	Safety Labels	Check that all warnings labels, guides etc are attached and clearly legible.
Mechanical systems	8	Mast and cradle	Not twisted or damaged. No cracked or broken welds.
	9	Inside mast	Lightly lubricate with silicone spray.
	10	Pivot roller	
	11	Cradle axle	
	12	Tipping guide flap	Check that flap is undamaged and moving freely.
	13	Castor wheels	Check that the castor wheels are running smoothly and both footbrakes are working correctly.



Date	Service Person	Location	Checks complete	Notes on repairs or maintenance required	Parts and materials used



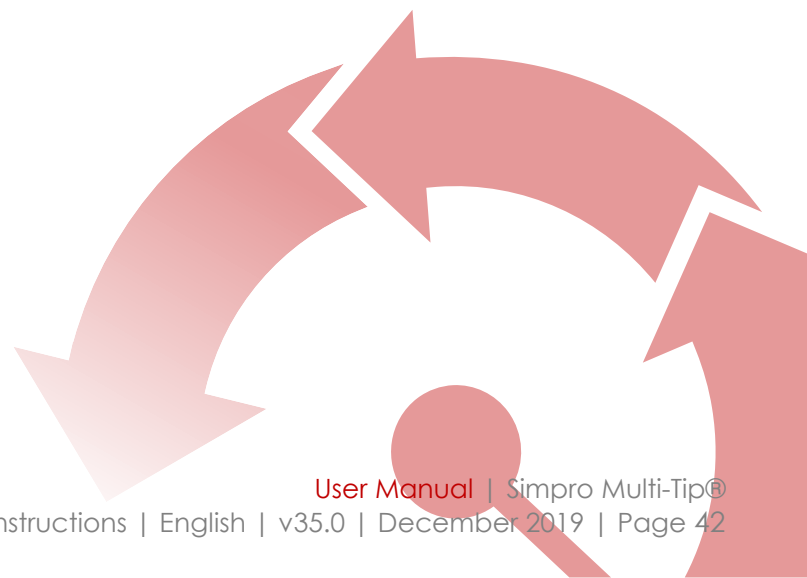

## 9. Warranty

### 9.1 Definitions

1. "Simpro" means Simpro Handling Equipment Limited, [New Zealand Registered Company No. 1827916](#).
2. "Agent" means a person or company authorized by Simpro to sell a Product.
3. "Service Agent" means a person or company authorized by Simpro to repair a Product.
4. "End User" means the first purchaser of a Product from a Sales Agent authorised by Simpro to sell the Product.
5. "Warranty" means the commitment that Simpro has to guarantee the workmanship and componentry to any End User of Products manufactured and sold by Simpro.
6. "Warranty Claim" means an application from an Agent to Simpro to be reimbursed for expenses relating to repairs done to remedy a fault with a Simpro Product.
7. "Warranty Period" means the length of time that Simpro undertakes to guarantee a Product.
8. "Back to Base" means that the costs associated with the transporting of a Product between the Service Agent and the End User is the End Users responsibility.
9. "Standard Products" means any Product displayed as a standard product on the Simpro website, <https://simpro.world/>.
10. "Part" and "Parts" refer to components of a Product.
11. "Minor Fault" means a fault or defect that requires less than one hour to rectify
12. "Instruction Handbook" means a document so titled that provides brief information and guidance on the operation of the Product for commonly performed functions.
13. "Service Manual" means a document so titled that provides comprehensive information and guidance for service, repairs and maintenance.
14. "Warranty Registration Process" means the process of an End User registering their product with Simpro. This may be done using the web form here: <https://simpro.world/support/warranty-registration>
15. "Application for Warranty Consideration Form" means the system used to file a Warranty Claim with Simpro. This may be done using the web form here: <https://simpro.world/support/warranty-claim>.

### 9.2 Coverage

1. Simpro provides a 12 month Back to Base Warranty on all Standard Products unless alternative terms have been agreed to in writing.
2. The Warranty terms and conditions on custom-built and non-standard machines are generally specified on quotations, and placing an order implies acceptance of the Warranty terms. If no specific Warranty details have been provided, the standard terms and conditions will apply.
3. The 12-month Warranty period shall be taken from the date the machine first leaves the Agent's premises, whether sold or just supplied for trial. The Agent shall keep accurate records of the date of all machine trials, sales, etc.
4. Simpro will, at its option, repair or replace any items that fail or prove defective within the Warranty period.
5. Simpro's liability under the terms of this Warranty shall be limited to remedying any fault that occurs on machines it has manufactured or supplied, and shall not cover any consequential loss or damage.
6. The Warranty on batteries is for 12 months only, and is distinct from the warranty on the rest of the machine. Information on maximising the life of your batteries may be viewed in the User Manual [Section 5.4.4.1](#).

### 9.3 Exclusions

1. Simpro will not recognise a Warranty Claim against a machine where payment to Simpro for that machine is outstanding. If a Warranty Claim is made before payment is due, the full payment must be made on the due date. The Warranty Claim, if accepted, will be credited at a later date.

2. Warranty Claims may not be recognized unless the [Warranty Registration Process](#) has been completed. If not done at the time of sale, this should be done at the time of the Warranty Claim. If warranty registration has not been completed, proof of purchase may be required.
3. Damage caused or contributed to by misuse, abuse, accident, unauthorised repairs or modifications, or failure to use the machine in accordance with instructions is specifically excluded.
4. Travelling time and mileage are specifically excluded from the Simpro warranty coverage. However under certain circumstances Simpro at its discretion may contribute to these costs. Authorisation must be obtained from Simpro prior to any such Warranty Claim. This does not prohibit an Agent offering more extensive Warranty cover, outside of this Warranty, as negotiated between the Agent and the End User.

## 9.4 End User claim procedure

1. Where a fault or breakdown appears to have occurred the End User should, if applicable, first consult the Quick Troubleshooting Guide section of the User Manual provided with each machine, to ascertain the cause of the fault and remedy if possible. This information may also be accessed on the Simpro Support website: <http://support.simpro.world>.
2. If the fault is not able to be remedied, the End User should contact the Agent who sold the machine, and explain as fully as possible the fault, including all relevant factors such as:-
  1. Did the fault occur suddenly or has it been giving trouble over some time?
  2. Was the machine being used at the time?
  3. Is the fault intermittent?
  4. Are the batteries fully charged?
  5. If repair is urgent, and the Agent cannot be contacted, the End User may contact Simpro direct.

## 9.5 Agent claim handling procedure

1. Upon receiving notification of a fault, the Service Agent should attempt to determine the cause and a course of action before going to see the machine.
2. The Service Agent should contact Simpro for assistance in identifying the fault, if it is not apparent. This step is important, so that if a site visit is necessary, the correct tools and spare Parts can be taken. It is also important to establish whether there may have been any negligence, misuse or an accident that contributed to or caused the fault.
3. Parts requiring replacement will be supplied by Simpro free of charge; in some cases, it may be necessary to source Parts locally if needed urgently, but Simpro must authorize this if the cost of the item exceeds \$50.00 and is to be charged to Simpro.
4. If the fault is not a Minor Fault, the Agent must notify Simpro and receive authorization to proceed before the repair work is done. Simpro will assist in every way possible, including discussing the problem directly with the End User if necessary, to determine the best method of effecting the repair in the shortest time possible.
5. Upon completion of the repair to an acceptable standard, the Agent shall complete the [Application For Warranty Consideration Form](#) and include copies of any invoices for labour, and any Parts supplied.
6. The cost of Warranty repairs is not to be deducted from any payments due to Simpro, unless Simpro issues a credit note clearly stating the amount and which invoice it relates to.
7. Simpro undertakes to be reasonable in respect of all Warranty repairs undertaken by Agents, but reserves the right to decline payment for:-
  1. Work done or materials replaced that were not authorized in advance by Simpro.
  2. Work not done to an acceptable standard.
  3. Work taking an unduly long time, due (in part or in full) to the lack of knowledge or skill of the serviceman or the Agent. The time allowed for repair work will be based on Simpro's assessment of what a reasonably skilled tradesman would take. Full Service Manuals are available on request at any time from Simpro and all service visits should be conducted with a Service Manual at hand.

This warranty shall be interpreted according to the laws of New Zealand and the parties agree to submit to the jurisdiction of the Courts of New Zealand.

## 10. EC Declaration of Conformity



### DECLARATION OF CONFORMITY

ORIGINAL

**Business Name and Full Address of Manufacturer**

---

Simpro Handling Equipment Ltd  
66 Rangī Road, Takanini 2105  
Auckland, New Zealand

**Name and Address of Authorised Representative**

---

As above

**Name and Address of the Person in Community Authorised to compile the Technical File (if different to above)**

---

Safe Machine Limited  
DBH Business Centre, Coxwold Way, Billingham, Tees Valley TS23 4EA UK

**Description of product (Commercial Name)**

---

Multi-Tip

**Function, Model, Type, Serial Number**

---

Function: Bin Tipper  
Type:

Model: Multi-Tip  
Serial No:

**Standards Used**

---

EN 349 1993, EN 574 1996+A1:200, EN 953 1997, EN ISO 4413 2010, EN ISO 12100 2010, EN ISO 13849-1 2006, EN ISO 13857 2008, EN 60204 2006+A1 2009, EN 61000-6-2 2005, EN 61000-6-4 2007

**Place of Declaration**

---

66 Rangī Road, Takanini 2105  
Auckland, New Zealand

**Date of Declaration:**

---

24 February 2018

**Declaration**

---

I declare that the machinery fulfils all the relevant provisions of the following Directives:- Machinery Directive 2006/42/EC, Electromagnetic Compatibility Directive 2004/108/EC.

**Person Empowered to Draw Up Declaration**

---

Name: Daniel Craig Currie

Position: Business Development Manager

Signature:

**Declaration No: 002**



## *II. Notes*

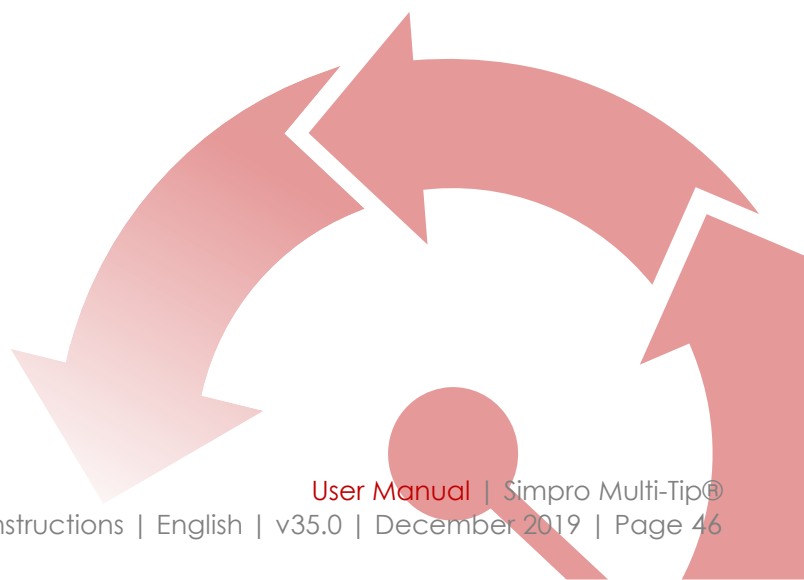



 Simpro has been manufacturing and retailing smart lifting solutions for over thirty years.

From humble beginnings as a small engineering firm in Auckland, New Zealand, the company has grown to become a leading supplier of handling equipment for niche applications – such as bin-lifting, tipping and handling machines, crate stackers and goods lifts.

Simpro products play an unobtrusive but essential role for thousands of companies around the world, in industries as diverse as waste management, food processing,

resource extraction and pharmaceutical manufacturing. They are available through a network of agents which spans the globe, and are backed by a sophisticated in-house design and fabrication capability.

Simpro is a family-owned company, registered with the New Zealand Companies Office as Simpro Handling Equipment Ltd, company no. 1827916.

The products in this document may contain intellectual property, including design elements registered to or licensed by Simpro Handling Equipment Ltd.

 66 Rangi Road  
Takanini 2105  
Auckland, New Zealand

 PO Box 202236  
Southgate, Takanini 2246  
Auckland, New Zealand

 +64 9 634 7445

 sales@simpro.world

 shop.simpro.world

 @simpro.world

 @SimproWorld\_Lifters

