

HOEFLON[®]

USER MANUAL

TRACKED CARRIER TC1

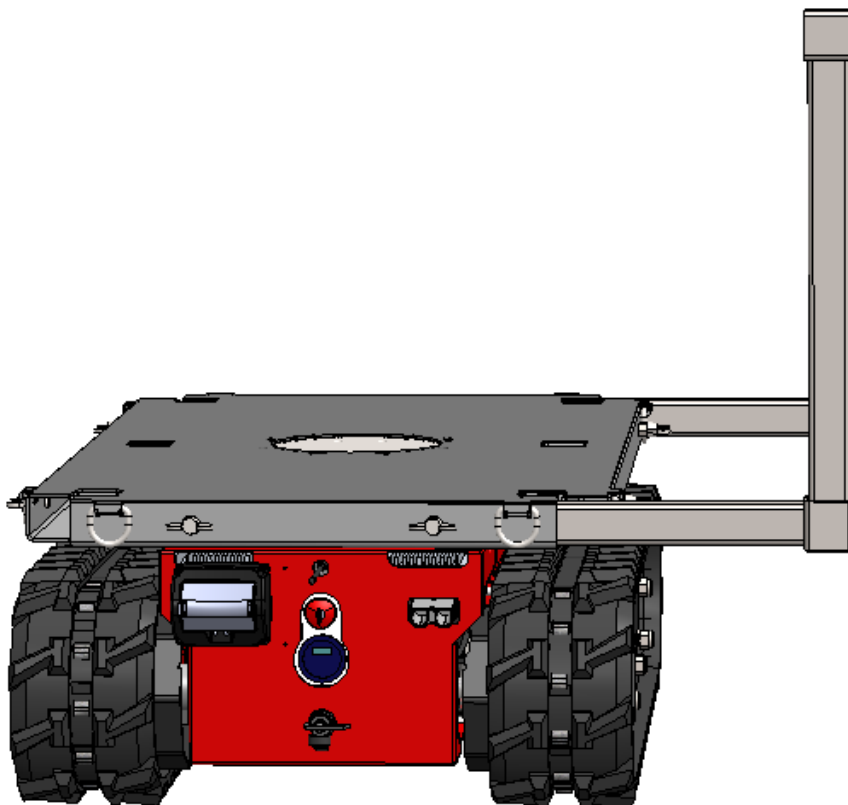

Manufacturer: Hoeflon International B.V.
Zwolleweg 2
3771 NR Barneveld
T: +31(0)342 400 288
I: www.hoeflon.com
E: info@hoeflon.com

Type

Serial no.:

Delivery date:

Aflevering kwitantie / Receipt of delivery / Übergabeerklärung / Aavis de livraison / Resguardo de entrega			
Machine serie nr. / Machine serial no. / Maschinen seriennummer / Numéro de série / Número de serie 	Datum van aflevering / Date of delivery / Lieferdatum / Date de livraison / Fecha de entrega - -		
Klantnaam / Customer Name / Kundename / Nom du client / Nombre del cliente Adres / Address / Adresse / Adresse / Dirección Postcode / Zip code / Postleitzahl / Code postal / Código postal Plaats / Place / Ort / Lieu / Lugar Land / Country / Land / Pays / Pais 	Dealer naam / Dealer Name / Händlers name / Nom du revendeur / Nombre del distribuidor Adres / Address / Adresse / Adresse / Dirección Postcode / Zip code / Postleitzahl / Code postal / Código postal Plaats / Place / Ort / Lieu / Lugar Land / Country / Land / Pays / Pais 		
<p>Bij de hierboven genoemde machine ontving ik de gebruikershandleiding. Tevens zijn mij de gebruik, veiligheid en onderhoudsvoorschriften uit gelegd. / In the above machine I received the user manual. I also laid down the use, safety and maintenance instructions. / In der obigen Maschine habe ich die Bedienungsanleitung erhalten. Ich habe auch die Gebrauchs-, Sicherheits- und Wartungsanweisungen festgelegt. / Dans la machine ci-dessus, j'ai reçu le manuel de l'utilisateur. J'ai également défini les instructions d'utilisation, de sécurité et de maintenance. / En la máquina de arriba recibí el manual de usuario. También establecí las instrucciones de uso, seguridad y mantenimiento.</p>			
Handtekening van de klant Signature of the client Unterschrift des Kunden Signature du client Signatura del cliente	<input type="text"/>	Handtekening van de dealer Signature of the Dealer Unterschrift des Händlers Signature du revendeur Signatura del distribuidor	<input type="text"/>
<p>Dit formulier ingevuld en ondertekend terug zenden naar Hoeflon B.V. Bij voorkeur inscannen en mailen of een foto van dit ingevulde formulier mailen. / This form filled in and signed back to Hoeflon B.V. Preferably scan and mail or mail a picture of this completed form. / Dieses Formular wurde ausgefüllt und an Hoeflon B.V. Scannen und mailen Sie am besten ein Bild dieses ausgefüllten Formulars. / Ce formulaire rempli et signé à Hoeflon B.V. De préférence, numériser et poster ou poster une photo de ce formulaire rempli. / Este formulario se completó y se firmó nuevamente con Hoeflon B.V. Preferiblemente escanee y envíe por correo o correo una foto de este formulario completo.</p>			
<p>Zonder ingevuld en retour ontvangen formulier nemen wij geen garantie aanvragen van de machine in behandeling. / Unless filled in and returned, we will not accept any warranty requests from the machine. / Sofern nicht ausgefüllt und zurückgesendet, akzeptieren wir keine Garantieforderungen von der Maschine. / Sauf si rempli et retourné, nous n'accepterons aucune demande de garantie de la machine. / A menos que se complete y devuelva, no aceptaremos ninguna solicitud de garantía de la máquina</p>			

PREFACE

This user manual is for the Tracked Carrier, type TC1. Throughout the rest of this document this type will simply be referred to as Tracked Carrier. Read this entire user manual carefully to become familiar with the correct operation and maintenance of the Tracked Carrier. If you choose to ignore the guidelines and instructions in this user manual you do so entirely at your own risk, and bodily injury and damage to the machine may result.

Hoeflon International B.V. recommends that the original copy of this user manual, including all the annexes, be kept in a safe, central place. It is also a good idea to keep a copy of this user manual near the machine at the workplace. For technical support, please contact the manufacturer (see details on the cover).

NOTES FOR THE READER

The instructions, recommendations and warnings in this user manual are accompanied by the following terms/pictograms. Read these instructions carefully.



TIP

A 'Tip' provides the user with suggestions and advice that will make it easier or more convenient to perform certain tasks.



CAUTION!

'Caution!' The operation may be dangerous. 'Caution!' indicates that damage to the machine may occur if the user does not perform the procedures with due care.



WARNING!

'Warning!' The user may injure himself or seriously damage the machine. A warning indicates a situation in which the user may be harmed or damage may occur to the machine, tool or load if the user does not perform the procedures carefully.



DANGER!

'Danger!' Warns that a hazard or hazardous condition may be life threatening.

PROPERTY RIGHTS

All rights reserved. No part of this publication may be reproduced, stored in a retrieval system, or transmitted in any form or by any means (electronically or mechanically, including photocopying, recording or otherwise) without the prior written permission of Hoeflon International B.V. This also applies to the accompanying drawings and charts.

© Copyright 2017

Table of contents

PREFACE	5
NOTES FOR THE READER	5
PROPERTY RIGHTS	5
Table of contents	6
1. INTRODUCTION	8
1.1. Introduction.....	8
1.2. EC Declaration of Conformity.....	8
1.3. Changes	8
2. GENERAL DESCRIPTION	9
2.1. Intended use.....	9
2.2. Main components of Tracked Carrier	9
2.3. Technical data	10
2.3.1. Technical specifications.....	10
2.3.2. Drawings.....	11
2.3.3. Electrical system	11
2.4. Type plate	12
3. GENERAL INSTRUCTIONS FOR USE	13
4. WARRANTY	14
5. SAFETY	14
5.1. Operating personnel.....	14
5.2. Warnings	14
5.3. Emergency stop.....	18
5.4. Pictograms.....	18
6. WORKING WITH THE TRACKED CARRIER	20
6.1. Daily inspection prior to use.....	22
6.2. Controls	23
6.2.1. Remote control.....	23
6.2.2. Changing the transmitter battery.....	25
6.2.3. Control panel	26
6.3. Working principle/operation Tracked Carrier	27
6.3.1. Order of operations.....	27
6.3.2. Attachment of the uprights.....	29

6.3.3.	Securing the load.....	29
6.3.4.	Slewing the platform (optional)	30
6.3.5.	Driving with the converter (optional).....	30
6.4.	Explanation of display while working with the Tracked Carrier.....	31
6.5.	Battery charging and state of charge	32
7.	MAINTENANCE/TROUBLESHOOTING	33
7.1.	General	33
7.2.	Maintenance work	34
7.3.	Maintenance schedule	35
7.4.	Lubricant specifications.....	35
7.5.	Lubrication chart	36
7.6.	Troubleshooting	37
7.7.	Motor controller data.....	38
7.8.	Fault codes	39
8.	TRANSPORT, STORAGE, DISPOSAL	40
8.1.	Transport	40
8.1.1.	General	40
8.1.2.	Securing.....	41
8.2.	Storage	42
8.3.	Disposal	42
9.	ANNEXES	43

1. INTRODUCTION

1.1. Introduction

The purpose/function of this user manual is to establish safe and efficient interaction between man and machine. The information in this user manual plays an important role in ensuring the safe and proper operation of the machine.

Read this user manual carefully from beginning to end. Hoeflon International B.V. also recommends a brief compulsory training and instruction session for all new users (operators, technicians, maintenance personnel and possibly even cleaners), for which this user manual can serve as a starting point.

Persons who work with the Tracked Carrier must wear safety shoes, gloves and a safety helmet.

Contact your supplier's technical department for additional information concerning aspects such as maintenance and repair of specific machine parts. This user manual has been written with the greatest possible care and with the intention of making it as complete as possible. Nevertheless, continuous safety vigilance in both familiar and unfamiliar situations is always necessary.

1.2. EC Declaration of Conformity

Hoeflon International B.V. declares that the Tracked Carrier meets the requirements of the applicable European Directives. The EC Declaration of Conformity is attached as an annex.

1.3. Changes

Changes may only be made to the Tracked Carrier after written consultation with Hoeflon International B.V.

All changes to the machine must be documented in this user manual as well as in all copies. The party that makes the changes is responsible for doing so.

Hoeflon International B.V. reserves the right to make immediate adaptations or changes that improve the safety of the machine at any time. These adaptations or changes will be documented in an annex to this user manual. The content of this user manual can also be changed without prior notice.

2. GENERAL DESCRIPTION

2.1. Intended use

The Tracked Carrier is intended exclusively for the transport of goods. The objects to be transported must fall within the specifications described in the user manual. The environmental and ground conditions required for the Tracked Carrier to operate properly are also described here.

The operation and results are partially dependent on the user's skill level. The many variables involved make it impossible to provide any well-founded (daily) production figures.

The Tracked Carrier is intended for indoor and outdoor use.

The Tracked Carrier must be operated with the remote control.

2.2. Main components of Tracked Carrier

The main components of the Tracked Carrier are shown below.

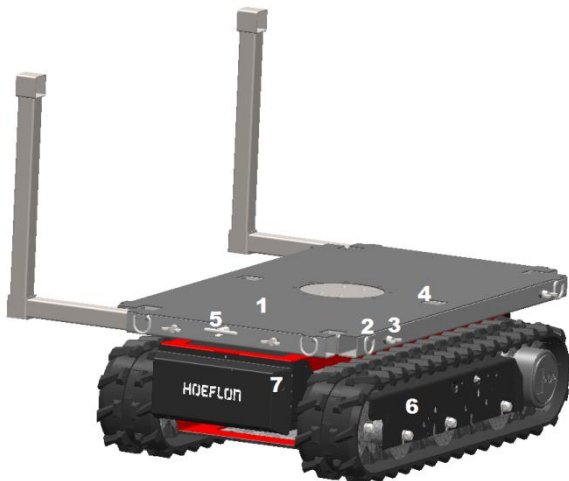

Figure: 1



Figure: 2

- 1 Platform (optionally slewing)
- 2 Lashing rings
- 3 Wing bolt to secure uprights
- 4 Upright hole
- 5 Turntable lock
- 6 Track undercarriage
- 7 Plug (230 V) for charging the batteries

- 8 Battery charger (transmitter battery)
- 9 Main switch
- 10 Battery indicator
- 11 Emergency stop
- 12 Antenna
- 13 Charging plug
- 14 Uprights

2.3. Technical data

2.3.1. Technical specifications

The technical data for the Tracked Carrier are shown below.

Technical data	
Machine brand	Hoeflon
Serial number	03 12 1089 TC1 (1089 = service number)
Maximum slope angle	20°
Clearance angle	45°
Maximum lean angle	20°
Ground clearance	60 mm
Capacity	2x 2kW
Battery pack	24 V
Battery life	13 hours (battery charger 230 V, 50 Hz)
Driving speed	2.2 km/h
Transport length	1450 mm
Transport width	800 mm
Transport height	420 mm
Ambient temperature	-10 to 40 °C
Platform slewing angle	Endless
Max. load-bearing capacity of platform	1200 kg
Mass of non-loaded machine	500 kg
Max. load-bearing capacity of uprights	200 kg per upright
Maximum wind speed	No wind restrictions

2.3.2. Drawings

The views of the Tracked Carrier are shown below.

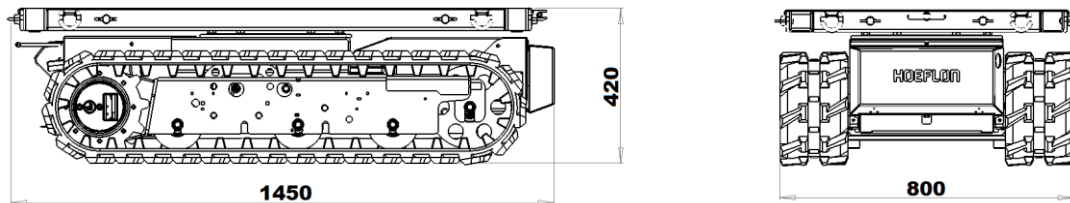

Figure 3: front and side view TC1

2.3.3. Electrical system

The specifications for the electrical system are shown below.

Electrical system	
Battery	4x 12V
Electric motor	2x 24V 2kW
Remote control	Hoeflon

2.4. Type plate

A type plate containing the machine data is mounted on the Tracked Carrier. This type plate may not be removed.



Figure: 4

The CE Marking is shown on the type plate to show that the Tracked Carrier meets the requirements of applicable European Directives.

Type plate explanation	
Type	The type of Tracked Carrier (TC1)
Model	The brand of the Tracked Carrier
Serial no.	The serial number of the Tracked Carrier
Year	The year in which the Tracked Carrier was built
Weight	The weight of the Tracked Carrier
Max. capacity	Maximum working load



TIP

Please provide the type number and serial number when ordering parts.

3. GENERAL INSTRUCTIONS FOR USE

The Tracked Carrier is a machine intended for lifting loads. It is only permitted to use the Tracked Carrier for the intended uses. Additionally, you are not permitted to change movement speeds on your own. It is also absolutely forbidden to exceed the maximum working load. If changes are desired, you must contact the manufacturer.

Before the machine is put in use the user must be sufficiently familiar with this user manual. All the instructions and safety warnings in this user manual must be followed. Any use other than the permitted use may result in danger to users and bystanders. Moreover, the machine may also be damaged. It is not permitted to use the machine in a way other than prescribed without express written permission from Hoeflon International B.V.

Every employee must be familiar with all the instructions in this user manual. Failure to heed this requirement is considered to be negligence.

4. WARRANTY

A new Tracked Carrier is covered by a 12-month warranty.

The warranty starts on the day the Tracked Carrier is first put in use. This is also the day that is stated on the warranty form.

If changes are made to the Tracked Carrier by anyone other than a Hoeflon International B.V. employee, the warranty will be void.

No warranty is given on the following parts:

- Imitation parts or parts that were not supplied by Hoeflon International.
- Labour charges for installation/repair of the Tracked Carrier.
- Parts that have become defective due to incorrect/improper use, overloading, lack of maintenance, incompetence, accidents, normal wear, etc.
- Parts required for scheduled maintenance.
- If a completed warranty form is not returned to Hoeflon International B.V.
- Reimbursement will only be provided for the parts.

The full terms and conditions of the warranty are available from your dealer on request.

5. SAFETY

5.1. Operating personnel

Operating personnel may not be under the influence of narcotics or alcohol and must be at least 18 years of age. These persons must be familiar with all the functions and tools associated with this transport machine. Persons who work with the Tracked Carrier must wear safety shoes, gloves and a safety helmet.

5.2. Warnings

The Tracked Carrier has been designed to be as safe as possible; pictograms on the machine warn of any remaining potentially dangerous situations. Do not remove these pictograms. Replace the pictograms if they become worn or damaged.

Every employee must heed the following warnings/regulations.



DANGER!

Never allow unauthorised persons to come within the working range or the danger zone of the machine when it is in motion.



DANGER!

Never climb on the machine when it is in motion or when it is being used.



DANGER!

Avoid contact with rotating parts.



DANGER!

It is prohibited to use the Tracked Carrier in an explosive environment.



DANGER!

Make sure the load bearing capacity of the ground is adequate; use access mats. Caution: never drive over manholes or alongside/through holes.



DANGER!

It is prohibited to use the Tracked Carrier to transport or lift persons.



DANGER!

It is prohibited to use the Tracked Carrier to pull loads free, cause them to fall, push them or pull them at an angle.



DANGER!

Never transport the Tracked Carrier without first ensuring that the optional uprights are fully retracted and locked; otherwise there is a risk of dangerous situations and possible damage to the machine!



DANGER!

Ensure that the uprights are always secured.



DANGER!

Beware of the risk of tipping when slewing loaded platform.



DANGER!

It is prohibited to change settings; this can lead to dangerous situations and damage to the machine and immediately voids the warranty.



DANGER!

It is prohibited to load the Tracked Carrier with more than 1200 kg.



DANGER!

It is prohibited to use the uprights for loads in excess of 200 kg per upright.



DANGER!

It is prohibited to use the Tracked Carrier during thunderstorms.



DANGER!

It is prohibited to use the Tracked Carrier in heavy rain, snow, or high or wet grass.



DANGER!

It is prohibited to drive the Tracked Carrier through water deeper than 5 cm.



WARNING!

Only suitable, trained persons who are familiar with the content of this user manual and have completed the user training provided by Hoeflon International B.V. may operate or work with the Tracked Carrier!



WARNING!

Dangerous situations can arise in which there is intense interaction between the machine, the operator, the load, the surroundings and the ground. Thorough knowledge and preparation is a must.



WARNING!

It is prohibited to use the lashing rings on the platform for pulling loads or pulling something loose. The lashing rings are intended exclusively for fixing products to the platform.



WARNING!

It is prohibited to drive the Tracked Carrier on public roads; the Tracked Carrier is not equipped with the markings and lights required to do so.



WARNING!

Never transport a loaded Tracked Carrier.



CAUTION!

When working in a poorly lit environment, artificial light must be used to ensure that operations involving the Tracked Carrier can be performed safely.



CAUTION!

Take extra caution and safety measures in situations where the ground, the surroundings or the load strongly influences or restricts the use of the machine. When in doubt about the safe use of the machine, get advice from a specialist or contact your dealer or the manufacturer.



CAUTION!

The Tracked Carrier may only be moved by means of hold-to-run control. Always maintain a good view of the surrounding area, to avoid hitting people or objects.



TIP

Use communication equipment if the operator does not have a complete overview of the working area of the Tracked Carrier.



TIP

Never leave a machine unattended with the keys and remote control.



TIP

Keep the Tracked Carrier clean and prevent accumulation of contamination.



TIP

Follow national regulations concerning working conditions and work safety when using the Tracked Carrier.



TIP



Operate the Tracked Carrier with due care; never release the toggles abruptly.





5.3. Emergency stop

Emergency stop buttons are present at the back of the Tracked Carrier and on the remote control. Emergency stop buttons all have the same function: when activated they stop all movements. **Only operate the emergency stop in the event of an emergency or disaster.**

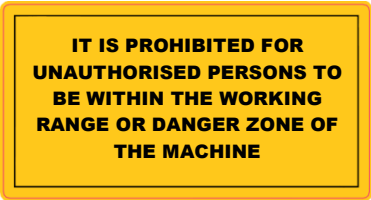
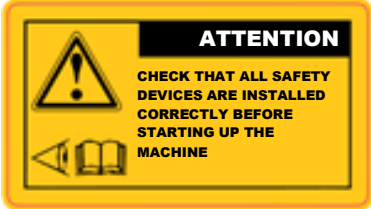
5.4. Pictograms

The pictograms used are shown below. These may not be removed. Missing or damaged pictograms must be replaced immediately!

Pictogram	Meaning	Location
	Use of safety shoes, gloves and safety helmet is mandatory.	On the back side
	Lifting point for lifting the machine	On the side of the platform
	Carriage of persons prohibited	On the side of the platform
	It is prohibited for unauthorised persons to be within the working range or DANGER ZONE of the machine.	On the back side
	Check that all safety devices are installed correctly before starting up the machine.	On the back side

Pictogram	Meaning	Location
	<p>Always consult the user manual before taking any action.</p>	<p>On the back side</p>
	<p>Risk of cutting or severing</p>	<p>On the sides of the platform</p>
	<p>Risk of trapping hands</p>	
	<p>Warning for radio remote control</p>	<p>On the back side, near the antenna</p>

6. WORKING WITH THE TRACKED CARRIER

Every employee must observe the following rules/warnings while working with the Tracked Carrier.



DANGER!

Never enter the working area; this can have serious consequences.



DANGER!

Do not let unauthorised persons enter the working area of the Tracked Carrier.



DANGER!

It is prohibited to use the Tracked Carrier in an explosive environment!



DANGER!

The user is responsible for safe operation of the Tracked Carrier, the selection of appropriate accessories (based on intended use, capacity, validity of inspection stickers and visual inspection) and the personal safety of the operator and people in the vicinity.



WARNING!

Work safely at all times, taking into account the Tracked Carrier, surroundings, ground and load. Do not begin working if there is a plausible risk of a dangerous situation developing before appropriate measures have been taken.



WARNING!

Operate the Tracked Carrier with due care; to prevent jolts while driving, never release the levers suddenly. May only be operated by authorised persons!



WARNING!

Always perform the daily inspection first!



WARNING!

Always ensure that no hazardous situation can develop!



WARNING!

Ensure that the Tracked Carrier working area is tidy and cordoned off.



CAUTION!

Do not use the Tracked Carrier until precautions have been considered and taken to safeguard the user, the machine, the load, the surroundings and the ground.



CAUTION!

When it is necessary to perform other related work, switch off the control to prevent unintentional movements.



CAUTION!

Never leave the control unattended, unless the ignition key is removed.



CAUTION!

Never place loose parts on moving components of the Tracked Carrier.



TIP

The directions of movement of the remote control with respect to the Tracked Carrier match best if you are behind the Tracked Carrier.

6.1. Daily inspection prior to use

For your own safety and to obtain the maximum service life from your equipment, it is of great importance that you always inspect the condition of the Tracked Carrier before use. Resolve any problems you find, or have your maintenance dealer do so, before you use the Tracked Carrier again.

- Perform a thorough general visual inspection of the Tracked Carrier. Check for loose connections, accumulated dirt and any damage. Remove any dirt which has accumulated and have necessary repairs performed.
- Check that all protective caps and covers are in position and that all nuts and bolts are in place and secured firmly.
- Check whether the securing bolts for the uprights are present and secured.
- Visually inspect the tension and condition of the crawler tracks; If defects are found, contact the dealer.
- Drive the front of the crawler tracks onto a wooden beam. The middle part of the crawler tracks is lifted off of the ground. They may not sag more than 2 cm at the bottom. If they hang lower, they must be tightened.
- The tracks are tensioned by fitting the grease gun to the grease nipple in the centre of the track and pumping until the grease gun provides greater resistance (see *figure 5*). The crawler tracks must be tight.
- Check whether the toggles for operating the Tracked Carrier automatically return to the centre position.
- Make sure that all loose parts are correctly stored/secured.
- Check that the emergency stop button functions correctly; never use the machine if the emergency stop button is not functioning properly. If defective, always have this repaired immediately!
- Check the state of charge of the batteries, and charge them if necessary.

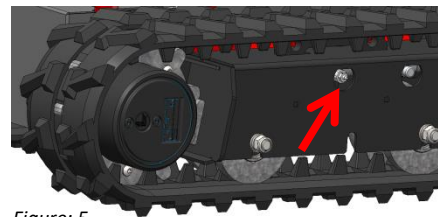

Figure: 5

6.2. Controls

6.2.1. Remote control

The Tracked Carrier is operated by remote control; the buttons and functions of the remote control are explained in this section.

- The transmitter is splash and rain-proof.
- Never clean the transmitter and receiver with high pressure and do not immerse them.
- Keep transmitter clean; ensure that pictograms, screen and labels remain legible.
- Wear the transmitter on the waist belt around your waist or over the shoulder with a shoulder strap.
- Always keep a second, fully charged transmitter battery at the ready.
- If the transmitter has poor or no contact, switch off the transmitter and the ignition switch of the machine. Switch on again and the transmitter automatically seeks a new frequency.



Figure: 6

Functions of the levers			
Number	Lever	Backwards	Forwards
1	L track	Backwards	Forwards
2	R track	Backwards	Forwards



Figure: 7

Buttons			
	Emergency stop	3	Display
	On/off button transmitter		This function is not used
	Activate receiver		Control panel display: ✓ Confirmation button ▲ Up arrow button ► Right arrow button ▼ Down arrow button ◀ Left arrow button ↶ Back button
	This function is not used		This function is not used
	This function is not used		This function is not used
	This function is not used		This function is not used
	This function is not used		This function is not used
	This function is not used		This function is not used
	This function is not used		This function is not used
	This function is not used		

6.2.2. Changing the transmitter battery

To change the battery in the transmitter, proceed as follows:

- Switch off the transmitter and the machine.
- Remove the battery from the transmitter (*figure 8*).
- Swap the battery in the transmitter with the battery in the battery charger on the back side of the Tracked Carrier (*see figure 9*). The battery in the battery charger on the back side of the Tracked Carrier charges up again when the Tracked Carrier is in use and if the main switch is in the on position. Attention! There is a half circle in the plastic on the battery and another on the battery socket. Make sure these are aligned with each other. Otherwise the battery will be backwards.
- The machine can be started again.
- See table below for meaning of the LEDs.



Figure: 8

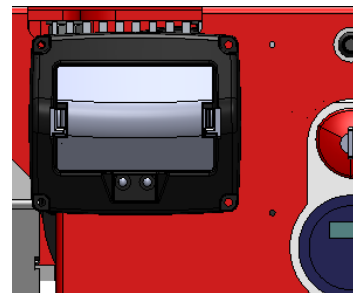

Figure: 9

Left LED		Right LED	
Battery charger status, for troubleshooting only		Battery status, for user	
LED status	Meaning	LED status	Meaning
Short green every 5 s	12V connected	LED off	Battery not connected
LED continuous red	Malfunction	LED continuous green	Battery charging 1A
		LED flashing green	Charging 0.3A
		LED off	Battery fully charged

6.2.3. Control panel

A number of functions are available on the control panel. These functions are shown and explained below.

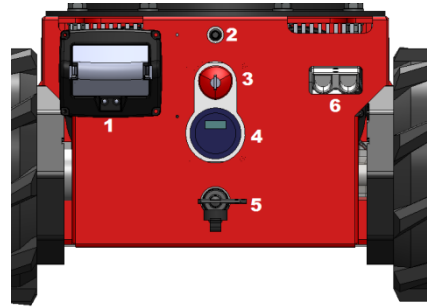

Figure: 10

Control panel on the back side of the Tracked Carrier		
Number	Component	Function
1	Battery charger with battery	Charges the transmitter's battery.
2	Antenna	Receives transmitter signal
3	Emergency stop	Turns off the machine as quickly as possible.
4	Battery meter	Indicates how much charge is left in the battery.
5	Main switch	Switches machine power on/off
6	Socket	Socket connection for optional converter.

6.3. Working principle/operation Tracked Carrier



DANGER!

Maximum slope angle 20°



DANGER!

Never exceed the maximum load capacity of the Tracked Carrier and load-bearing capacity of the uprights.



WARNING!

Operate the Tracked Carrier with due care; to prevent jolts while driving, never release the levers suddenly. May only be operated by authorised persons!



WARNING!

It is forbidden to drive through water more than 5 cm deep.



WARNING!

The Tracked Carrier is in no way suitable for dragging objects. This can lead to dangerous situations and damage to the machine!



TIP

The directions of movement of the remote control with respect to the Tracked Carrier match best if you are behind the Tracked Carrier.





TIP

Ensure that the batteries in the transmitter and Tracked Carrier are charged before you start to work with the machine.

6.3.1. Order of operations

To operate the Tracked Carrier, follow these steps in sequence:

- First perform the daily inspection.
- Ensure that no hazardous situations can develop.
- Check that the control levers are in the middle position.
- Switch off the emergency stop by pressing the key in the emergency stop button and turning it to the right.
- Turn on the main switch by turning it to the right. The battery charger and battery indicator lights will light up.

- Switch on the transmitter by pressing  on the transmitter (see figure 7).
- The display shows the following screen (see figure 11).
- Allow the transmitter to connect to the Tracked Carrier by pressing  on the transmitter (see figure 7).
- The display shows the following screen (see figure 12).
- The Tracked Carrier is now ready to drive.
- Simultaneously push levers 1 and 2 on the transmitter (see figure 7) forwards to drive straight forwards or backwards to drive straight backwards.
- Pushing lever 1 less than lever 2 will cause the Tracked Carrier to drive to the left.
- Pushing lever 2 less than lever 1 will cause the Tracked Carrier to drive to the right.
- The same applies for driving backwards.
- The driving direction is indicated by an arrow on the crawler track undercarriage (see figure 13).
- Stop the Tracked Carrier by releasing the toggles; they return to the centre position automatically.
- When the work is finished, perform the following steps.
- Park the Tracked Carrier in a safe place.
- Switch off the transmitter by pressing  on the transmitter (see figure 7).
- Switch off the main switch by turning the key to the left.
- Press the emergency stop, then turn the key to the left and remove it.
- If necessary, top up the battery charge for the next use.

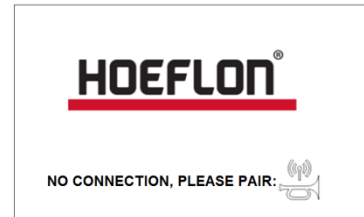

Figure: 11



Figure: 12

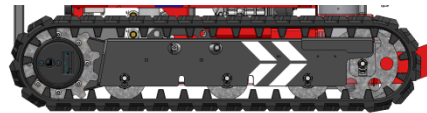

Figure: 13

6.3.2. Attachment of the uprights



DANGER!

It is prohibited to use the uprights for loads in excess of 200 kg per upright.



DANGER!

Ensure that the uprights are always secured.



CAUTION!

Be aware of the crushing danger when pushing in the uprights.

The Tracked Carrier has four uprights, which are stored in the sides of the turntable. The uprights can be placed horizontally in each corner of the long side or short side of the platform. There is also a tube at the end of each upright in which another upright can be inserted at a 90° angle.

- Sliding out the uprights.
- Loosen the wing bolt (green in figure 14) for the upright that is to be slid out (do not unscrew it all the way).
- Pull the upright out until the desired width is reached, or remove it completely.
- Retighten the wing bolt so the upright is secured at the set length. Tighten the wing bolt even if the upright is removed completely so that the wing bolt will not fall out.

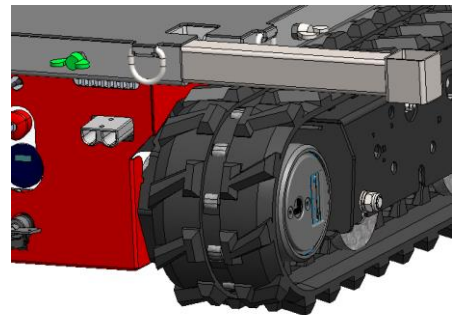

Figure: 14

6.3.3. Securing the load.

The load can be secured on the platform by means of the eyes on the sides of the platform. There is an eye on every corner of the platform (figure 15).

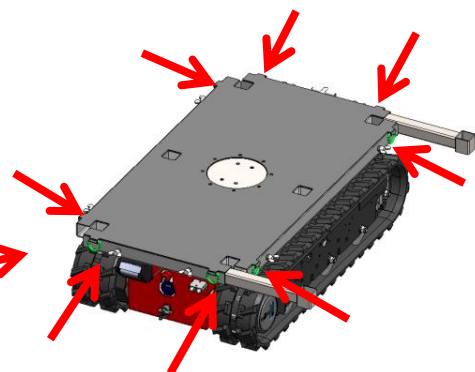
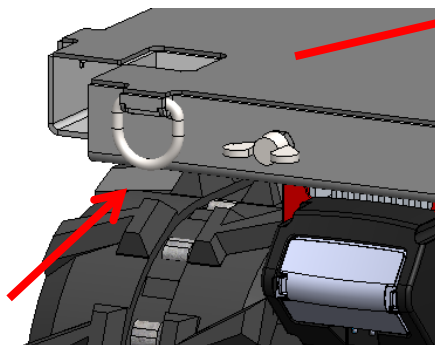

Figure: 15

6.3.4. Slewing the platform (optional)



DANGER!

Beware of the risk of tipping when slewing loaded platform.

The Tracked Carrier is also available with a rotatable platform, as an option.

- The platform can be endlessly rotated by pulling out the handle on the short side of the platform (figure 16).
- If the lever is pulled out and rotated a quarter turn, the platform remains unlocked.
- If the handle is released, it will automatically snap in and lock the platform. This will only occur if the handle has not been rotated, as explained in the previous step. If it has been, it must first be turned a quarter turn and will snap in and lock the platform.
- The platform only locks every 90°, not in every possible position.
- Make sure the platform is always locked before driving the Tracked Carrier.



Figure: 16

6.3.5. Driving with the converter (optional)

A converter is available with the Tracked Carrier as optional equipment. This converter makes it possible to drive when the batteries in the Tracked Carrier are discharged.

- The large plug of the converter is plugged into the socket on the Tracked Carrier (figure 17).
- The other plug of the converter is plugged into a 230 V mains socket.
- The Tracked Carrier can now drive again.
- Use an extension lead having conductors with sufficient cross-sectional area (2.5 mm²) and length.
- When you are finished using the machine, first remove the plug from the 230 V mains outlet and then the plug from the Tracked Carrier.

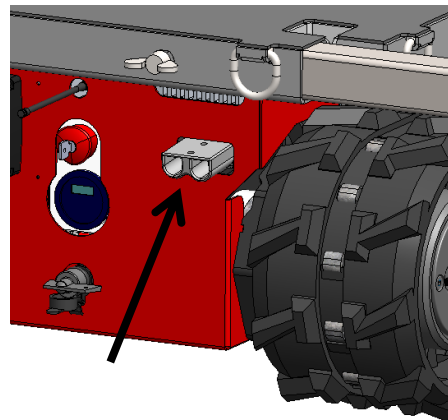

Figure: 17

6.4. Explanation of display while working with the Tracked Carrier.

While working with the Tracked Carrier, the following information is shown on the remote control display. The values that appear on the display are explained below.

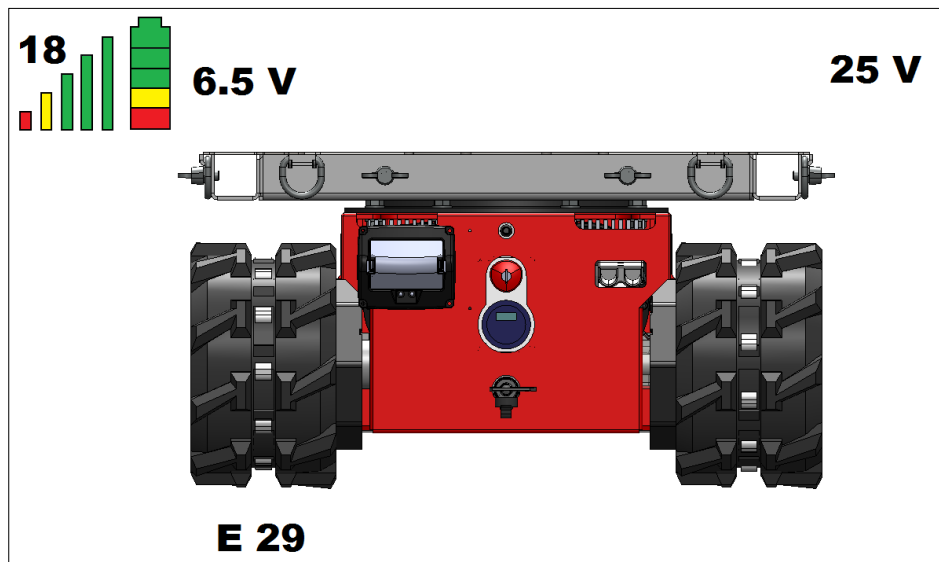

Figure: 18

- The transmission frequency is shown at the top left. See figure 18; here it is set to 18.
- The signal strength is indicated by 5 vertical bars. If the strength is good, they are all shown, as in figure 18. As the signal weakens, the green bars disappear first, then the yellow and red ones.
- The battery state of charge is shown in the battery symbol in the top-left corner of the screen. When the battery is fully charged, 3 green blocks, 1 yellow and 1 red are shown, as in figure 18. As the battery discharges, the blocks go out, one at a time.
- The voltage is shown in volts. In figure 18 this is 6.5 V.
- The voltage of the battery pack for the drive system of the Tracked Carrier ('25 V') is shown at the top right (figure 18).
- In the middle of the figure is a picture of the rear of the Tracked Carrier (figure 18).
- An error code can be displayed below the left and right tracks. In figure 18 the error code E29 is shown below the left track. The explanation of the error codes can be found in section 7.8.

6.5. Battery charging and state of charge



WARNING!

During the charging process an explosive gas mixture is formed in the battery pack. Short circuits, open flame and spark discharge in the immediate vicinity of the battery may cause an explosion.

The Tracked Carrier is powered by batteries inside the machine. The state of charge of the batteries is shown by a meter on the back side (*figure 19*).

This is displayed as a bar graph. With each step an additional bar is lit. The rightmost bar (at the 'F') indicates 100% charged, and the leftmost (at the 'E') is 0%.

When the state of charge drops below 20% it is important to connect the Tracked Carrier to the battery charger as soon as possible so the batteries are recharged.



Figure: 19

Charging the batteries in the tracked carrier.

- Pull the plug out of the front side of the Tracked Carrier (*figure 20*).
- Insert the plug into a 230 V mains socket.
- The batteries in the tracked carrier are now being charged.
- When the batteries are fully charged the 'F' bar on the battery meter will light up (*figure 56*).
- Remove the plug from the socket.
- Push the power lead and a bit of the plug into the front of the Tracked Carrier (*figure 20*).



Figure: 20

7. MAINTENANCE/TROUBLESHOOTING

7.1. General



DANGER!

Remove the key from the main switch and emergency stop button before performing work on the Tracked Carrier.



DANGER!

Always correctly reinstall any protection measures that have been removed!



WARNING!

Only your dealer or Hoeflon International may perform work on the electrical system of the machine.

The maintenance instructions are presented in this chapter. Proper maintenance is the key to keeping the machine operating properly. It is very important that these instructions are followed, to ensure your safety and that of others who are present.

Unusual noises or vibrations can indicate a defect in the machine. It is then necessary to perform a repair or maintenance without delay. Consult your dealer about this.

Contact your dealer's technical department for additional information concerning aspects such as maintenance and repair of specific machine parts.

7.2. Maintenance work

The risk of accidents with machines is generally greater during maintenance, cleaning and service. Have your dealer perform the maintenance work on the Tracked Carrier. In the Netherlands you can choose to enter a maintenance contract with Hoeflon International B.V. The maintenance intervals and work required are shown in the lubrication chart and maintenance schedule.

Weekly maintenance

- See maintenance chart.
- Grease the Tracked Carrier in accordance with the lubrication chart.
- Clean the Tracked Carrier with water and a mild cleanser such as car wash shampoo. Never use solvents or other flammable liquids as a cleanser. Never direct the nozzle of a pressure washer directly at the motor or electrical parts.
- Clean the machine daily after use in or transport through a salty/briny environment. Be sure to remove all the salt/brine, to prevent corrosion of the machine.

Scheduled service

- The first scheduled service must be performed after 2 weeks or 50 hours of operation.
- Thereafter the Tracked Carrier requires scheduled service annually or every 250 hours of operation.
- It must also be inspected annually.
- It is recommended that you have the scheduled service and inspections performed by your dealer or Hoeflon International B.V.

First use

- Perform the daily inspection (see section 6.1).
- Test the following aspects of the Tracked Carrier:
 - Operation of emergency stop.
 - All functions work properly.
 - Safety provisions work properly.

7.3. Maintenance schedule

Description of maintenance	Action	interval (o = manufacturer/dealer, ● = owner)		
		Daily	Annually	Every 2 years
Crawler track undercarriage				
Tension of crawler tracks	Check/adjust	●		
Oil level track motors	Check/top up		o	
	Replace			o
General				
Safety devices	Check	●		
Control levers	Check	●		
Condition and presence of pictograms	Check	●		
Mechanical components	Check	●		
Turntable	Lubricate		o	
Construction incl. pins, shafts, etc.	Check		o	
Electrical system				
Wiring connectors	Check		o	
Emergency stop and sensors	Check	●		
Voltage	Check		o	

7.4. Lubricant specifications

Manufacturer:	Final drives	Lubrication points
Q8	T 55	EP 2
Total	EP-B 80W90	EP 2
Shell	Spirax S3 AX 80W-90	EP 2
Kroon oil	Gearlube GL-5 80W-90	EP 2

7.5. Lubrication chart

Lubricate the Tracked Carrier as shown in the lubrication chart in *figure 21*, paying particular attention to the following:

- Clean the grease nipples thoroughly before lubrication.
- Remove excess/old grease.
- Use clean greases, stored in sealed packaging.
- **Use only prescribed greases; see lubricant specifications.**

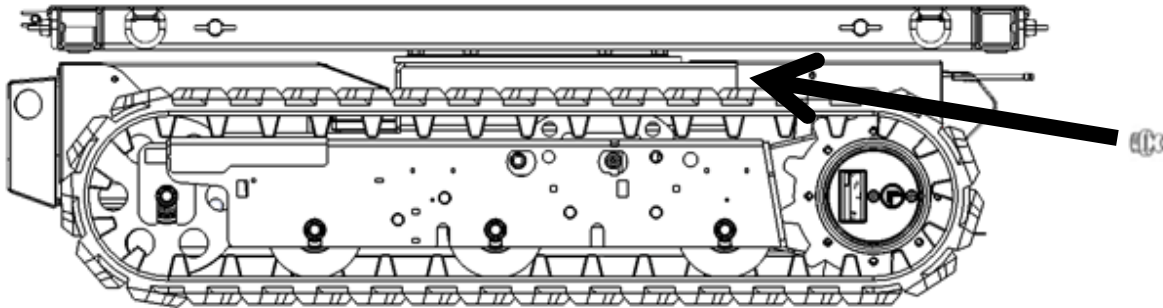

Figure 21

7.6. Troubleshooting



DANGER!

Remove the key from the key switch when performing work on the Tracked Carrier.



WARNING!

When a leak has developed in a gearbox or final drive, not only repair the leak immediately but also top off the oil in the gearbox.



CAUTION!

Consult the dealer for troubleshooting.

Correct operation and careful maintenance ensure that the Tracked Carrier will have a long life with fewer problems.

The warnings above must be heeded for all work performed in connection with a malfunction.

A number of possible malfunctions are shown hereafter. If a malfunction occurs that is not listed in this user manual, contact your dealer or Hoeflon International B.V.

7.7. Motor controller data

It is possible to read out some data from the motor controller of the Tracked Carrier.

- Turn on the remote control and establish contact with the Tracked Carrier. Activate the remote control menu by pressing the (✓) button (see figure 21).
- Then open **Motor controller data** by pressing the (✓) button (see figure 22).
- Now the current data for the left and right motors are shown.
- Now press (↶) twice and you will return to the home screen.

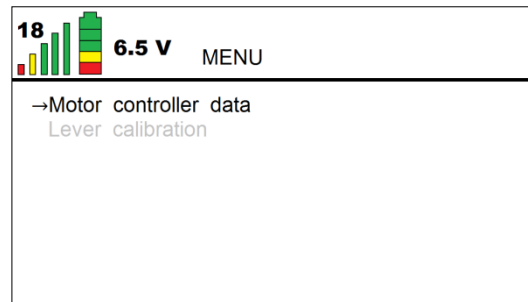

Figure: 21

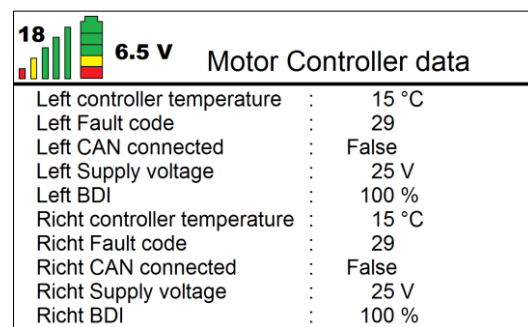

Figure: 22

7.8. Fault codes

The fault codes listed below may appear on the display of the remote control below the image of the tracks. See also *figure 18*.

Fault code	Problem	Possible solution. If this does not work, contact Hoeflon.
E0	Controller operational and OK	There are no faults
E1	Handbrake on	Contact Hoeflon
E2	Low voltage	Charge batteries
E3	Pump brakes	Check input switch
E4	High voltage	Contact Hoeflon
E5	Motor too hot	Reduce drive speed or temporarily stop the machine
E6	Carbon brushes defective	These must be replaced
E7	New settings out of range	Contact Hoeflon
E8	Default settings restored	Contact Hoeflon
E9	EEPROM unavailable	Contact Hoeflon
E10	Two driving directions selected	Check the levers on the remote control
E11	Seat switch open	Contact Hoeflon
E12	Sequence error	Contact Hoeflon
E13	Accelerator voltage too high at start-up	Contact Hoeflon
E14	Prohibited input selected	Problem with switch or wiring – Contact Hoeflon
E15	Voltage too low	Check battery state of charge
E16	-	-
E17	Voltage too low	Check battery state of charge
E18	MOSFET high short-circuit	Contact Hoeflon
E19	MOSFET low short-circuit	Contact Hoeflon
E20	Hardware over main power active	Contact Hoeflon
E21	Contact coil short-circuit	Contact Hoeflon
E22	Voltage too high	Contact Hoeflon
E23:	MOSFET low short-circuit in neutral	Contact Hoeflon
E24	Hardware file cannot turn off hardware	Contact Hoeflon
E25	Contact open- or short-circuit	Contact Hoeflon
E26	Real-time measurement error	Contact Hoeflon
E27	MOSFET low short-circuit	Contact Hoeflon
E28	Wire break	Contact Hoeflon
E29	CAN bus wire break	Contact Hoeflon
E30	Speed too high	Contact Hoeflon
E31	Motor sensor wire break	Contact Hoeflon
E32	Mechanical motor sensor error	Contact Hoeflon
E33	Reversed polarity	Contact Hoeflon

8. TRANSPORT, STORAGE, DISPOSAL

8.1. Transport

8.1.1. General



WARNING!

The clearance angle of the loading ramps must not exceed 15 degrees.



WARNING!

When transporting the Tracked Carrier, make sure the crane is in transport mode and that any load is removed: No load on the platform and the uprights pushed in and secured.



WARNING!

Overloaded eyes can cause damage to the machine. Therefore always heed the following instructions.

- Ensure that the uprights of the Tracked Carrier are fully retracted and secured.
- Ensure that there is no load on the Tracked Carrier.
- Use loading ramps of sufficient size and capacity. The loading ramps must be long enough so that the angle with the ground is less than 15°.
- Lift the Tracked Carrier using lifting straps or chain slings with a capacity of at least 750 kg. Fit these to the four hoisting eyes on the side of the platform (see figure 23).

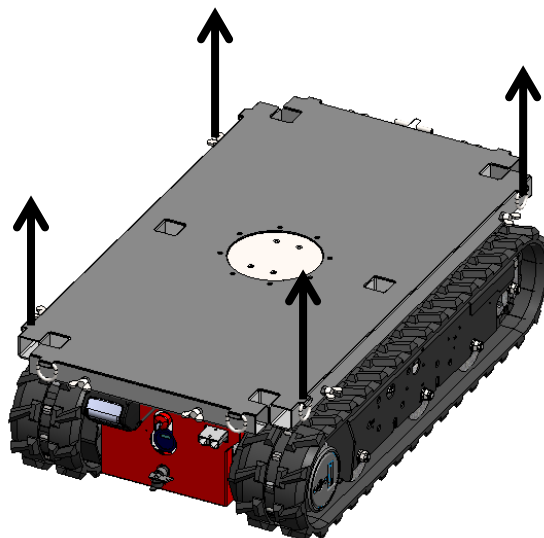

Figure: 23

8.1.2. Securing



WARNING!

Overloaded eyes can cause damage to the machine. Therefore always heed the following instructions.



WARNING!

Folding a lashing strap double also doubles the applied tension.

Point	Load on attachment point
Lashing points	Max. 1000 kg per eye

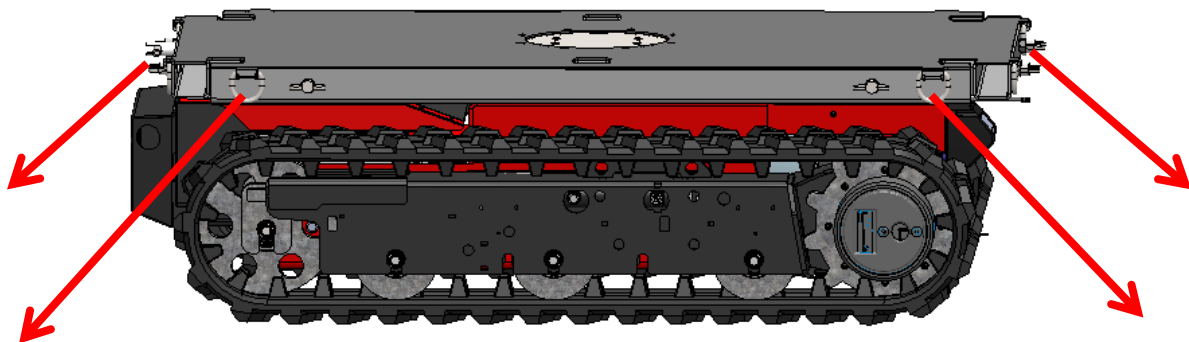

Figure: 24

- Towards the front and sides, lash down at least 0.5x the machine's weight; towards the rear lash down at least 1x the machine's weight (*figure 24*).
- It is recommended that the space between the headboard of the transport vehicle and the front of both tracks be filled, in connection with braking forces. Otherwise, use lashing provisions that can hold at least 1.5x the machine's weight at the rear.
- Ensure that the tracks of the Tracked Carrier are resting directly on the deck of the transport vehicle, because ground protection plates or anything similar in between will reduce the sliding resistance of the Tracked Carrier relative to the transport vehicle.

8.2. Storage

Perform the following procedure before storing the Tracked Carrier for longer than 3 months:

- Remove any dirt and clean the machine with water and e.g. car wash shampoo. The crawler track undercarriage may be cleaned at high pressure.
- Grease the Tracked Carrier in accordance with the lubrication chart in section 7.5.
- Touch up any damage to the paintwork.
- Place the Tracked Carrier in a dry location, protected from rain, heat and cold.
- Turn off the main switch.
- Ensure that the Tracked Carrier cannot be activated by unauthorised persons.
- Cover the Tracked Carrier with a tarpaulin; keep a strip along the floor uncovered to allow ventilation.

After the Tracked Carrier has been in storage for an extended period (longer than 3 months), follow these instructions:

- Remove the tarpaulin.
- Turn on the main switch.
- Check the battery voltage and charge if necessary.
- Perform the daily inspection.

**CAUTION!**

If the Tracked Carrier will be placed in storage for more than six months, contact Hoeflon International B.V. for the procedure to be followed.

8.3. Disposal

Dispose of waste in accordance with the applicable local regulations. Incorrect disposal of waste can be harmful to the environment. Environmentally harmful waste includes: engine oil, diesel fuel, hydraulic oil, differential oil, coolant, filters, batteries and greases.

9. ANNEXES

- EC Declaration