

# Instruction manual

**Operating & Maintenance**  
4812159301\_D.pdf

**Vibratory roller**  
**CA1300 D/PD**

**Engine**  
**Kubota V3307-CR-TE4B (IIIB/T4i)**  
**Kubota V3307-CR-TE5B (T5)**

**Serial number**  
**10000159xxA012196 -**  
**10000185xxA024300 -**



Translation of original instruction



---

## Table of Contents

Introduction .....	1
Warning symbols.....	1
The machine .....	1
Intended use .....	1
Safety information .....	1
General .....	2
CE marking and Declaration of conformity.....	3
Safety - General instructions.....	5
Safety - when operating .....	7
Work driving .....	7
Driving near edges .....	8
Strike-off blade .....	8
Special instructions .....	9
Standard lubricants and other recommended oils and fluids .....	9
Higher ambient temperatures, above +40°C (104°F).....	9
Temperatures.....	9
High pressure cleaning .....	9
Fire fighting .....	10
Roll Over Protective Structure (ROPS) .....	10
Battery handling .....	10
Jump starting.....	11
Technical specifications .....	13
Vibrations - Operator station .....	13
Noise level.....	13
Electrical system .....	13
Slopes .....	14
Dimensions, side view.....	15
Dimensions, top view .....	16
Weights and volumes .....	17
Working capacity .....	17

General .....	18
CO <sub>2</sub> -emission .....	18
Tightening torque .....	19
ROPS - bolts .....	20
Hydraulic system .....	20
Machine description .....	21
Diesel engine .....	21
Electrical system .....	21
Propulsion system/Transmission .....	21
Brake system .....	21
Steering system .....	22
Vibration system.....	22
FOPS and ROPS .....	22
Identification .....	23
Product and component plates .....	23
Product identification number on the frame .....	23
Machine plate.....	24
Explanation of 17PIN serial number.....	24
Engine plates .....	25
Machine description- Decals.....	27
Location - decals .....	27
Location - decals, CALIFORNIA .....	28
Safety decals.....	28
Info decals.....	31
Instruments/Controls .....	32
Locations - Instruments and controls .....	32
Locations - Control panel and controls.....	33
Function description .....	34
Electrical system.....	37
Fuses .....	37



Main fuses .....	38
Relays on machine.....	39
Operation .....	41
Before starting .....	41
Master switch - Switching on.....	41
Operator's seat - Adjusting.....	41
Driver seat (Equipment status) - Adjustment .....	42
Parking brake .....	42
Instruments and lamps - Checking.....	43
Interlock.....	43
Operator position.....	44
View .....	44
Starting .....	45
Starting the engine .....	45
Driving .....	47
Operating the roller .....	47
Operation of strike-off blade (Equipment status) .....	48
Interlock/Emergency stop/Parking brake - Check .....	48
Burnout of DPF filter.....	49
Vibration .....	50
Vibration On/Off .....	50
Vibration - Activation .....	51
Braking .....	51
Normal braking .....	51
.....	51
Emergency braking .....	52
Switching off.....	52
Parking .....	53
Chocking the drums .....	53

---

Master switch .....	53
Long-term parking .....	55
Engine .....	55
Battery .....	55
Air cleaner, exhaust pipe .....	55
Fuel tank .....	55
Hydraulic reservoir .....	55
Tires .....	55
Hoods, tarpaulin .....	56
Steering cylinder, hinges, etc. ....	56
Miscellaneous .....	57
Lifting .....	57
Locking the articulation .....	57
Lifting the roller .....	57
Unlocking the articulation .....	58
Towing .....	58
Short distance towing with switched off engine .....	58
Rear axle brake .....	59
Brake disengagement .....	59
Releasing the drum brake .....	60
Drum motor brake .....	60
Towing the roller .....	61
Transport .....	61
Securing CA1300 for loading .....	62
Operating instructions - Summary .....	65
Preventive maintenance .....	67
Acceptance and delivery inspection .....	67
Warranty .....	67
Maintenance - Lubricants and symbols .....	69
Maintenance symbols .....	71

Maintenance - Maintenance schedule .....	73
Service and maintenance points .....	73
General .....	74
Every 10 hours of operation (Daily).....	74
After the FIRST 50 hours of operation .....	74
Every 50 hours of operation (Weekly).....	75
Every 250 / 750 / 1250 / 1750 hours of operation .....	75
Every 500 hours of operation .....	76
Every 1000 hours of operation .....	77
Every 1500 hours of operation .....	78
Every 2000 hours of operation .....	79
Service - Checklist.....	80
Maintenance, 10h .....	81
Air circulation - Check .....	81
Coolant level - Check .....	81
Fuel tank - Filling.....	82
Diesel engine Check oil level .....	82
Brakes - Check.....	83
Hydraulic reservoir - Check fluid level.....	84
Maintenance - 50h .....	85
Scrapers - Check, adjustment.....	85
Tires - Air pressure - Wheel nuts - Tightening .....	86
Air cleaner Check - Replacement of main filter .....	86
Air filter indicator - Resetting .....	87
Backup filter - Change.....	87
Air cleaner - Cleaning.....	88
Air cleaner - Check hoses and connections .....	88
Pre-fuel filter - Draining .....	89

---

Maintenance measures - 250 h .....	91
Rear axle differential - Check oil level .....	91
Rear axle pinion housing - Checking the oil level .....	91
Rear axle planetary gears - Check oil level.....	92
Drum - Checking the oil level .....	92
Coolers Checking - Cleaning .....	93
Bolted joints - Checking tightening torque.....	93
Rubber elements and fastening screws - Check.....	94
Battery - Check condition .....	94
Maintenance measures - 500 h .....	95
Rear axle differential - Check oil level .....	95
Rear axle pinion housing - Checking the oil level .....	96
Rear axle planetary gears - Check oil level.....	96
Drum - Checking the oil level .....	97
Coolers Checking - Cleaning .....	97
Bolted joints - Checking tightening torque.....	98
Rubber elements and fastening screws - Check.....	98
Battery - Check condition .....	99
The engine fuel filter - replacement/cleaning .....	99
Diesel engine - Oil- and Filter change.....	100
Forward/Reverse controls and joints - Check and lubrication .....	101
Controls and moving joints - Lubrication .....	102
Maintenance - 1000h .....	103
Drum - Checking the oil level .....	103
Coolers Checking - Cleaning .....	104
Bolted joints - Checking tightening torque.....	104

---

Rubber elements and fastening screws - Check.....	105
Battery - Check condition .....	105
The engine fuel filter - replacement/cleaning .....	106
Diesel engine - Oil- and Filter change.....	107
Forward/Reverse controls and joints - Check and lubrication .....	108
Controls and moving joints - Lubrication .....	109
Hydraulic filter - Replacement .....	109
Fuel tank - Cleaning .....	111
Fuel tank - Draining (Equipment status).....	111
Hydraulic reservoir - Draining.....	112
Rear axle differential - Oil change.....	112
Rear axle pinion housing - Oil change .....	113
Rear axle planetary gear - Oil change .....	113
Maintenance - 2000h .....	115
Hydraulic reservoir - Oil change.....	115
Forward/Reverse controls and joints - Check and lubrication .....	116
Battery - Check condition .....	116
Bolted joints - Checking tightening torque.....	117
Coolers Checking - Cleaning .....	117
The engine fuel filter - replacement/cleaning .....	118
Controls and moving joints - Lubrication .....	119
Diesel engine - Oil- and Filter change.....	120
Hydraulic filter - Replacement .....	121
Fuel tank - Cleaning .....	122
Fuel tank - Draining (Equipment status).....	122
Hydraulic reservoir - Draining.....	123
Rear axle differential - Oil change.....	123
Rear axle pinion housing - Oil change .....	124

Rubber elements and fastening screws - Check.....	124
Drum - Oil change .....	125
Steering joint - Check.....	126
Rear axle planetary gear - Oil change .....	126

## Introduction

### Warning symbols

#### The machine

CA1300 is a 5 ton vibratory roller intended for compaction work in trenches, on roads and in confined areas in conjunction with refilling work.

#### Intended use

CA1300 is available in a D (smooth drum) and PD (padfoot) version. The smooth drum version with drum drive (D) ensures good accessibility even on very steep slopes. The PD version, with pads and drum drive, is specially intended for the compaction of silt and loamy soils. The roller can also be used for repair work on dams, power stations, car parks and airfields.



**WARNING !** Marks a danger or a hazardous procedure that can result in life threatening or serious injury if the warning is ignored.



**CAUTION !** Marks a danger or hazardous procedure that can result in damage to the machine or property if the warning is ignored.

### Safety information



**It is recommended to at least train operators in handling and daily maintenance of the machine in accordance with the instruction manual. Passengers are not allowed on the machine, and you must sit in the seat when operating the machine.**



**The safety manual supplied with the machine must be read by all roller operators. Always follow the safety instructions. Do not remove the manual from the machine.**



**We recommend that the operator reads the safety instructions in this manual carefully. Always follow the safety instructions. Ensure that this manual is always easily accessible.**



**Read the entire manual before starting the machine and before carrying out any maintenance.**



**Replace immediately the instruction manuals if lost, damaged or unreadable.**



**Ensure good ventilation (extraction of air by fan) where the engine is run indoors.**

CALIFORNIA

### **Proposition 65**

Decal and location of decal shown in section Machine description.

**⚠ WARNING:** Breathing diesel engine exhaust exposes you to chemicals known to the State of California to cause cancer and birth defects or other reproductive harm.

- Always start and operate the engine in a well-ventilated area.
- If in an enclosed area, vent the exhaust to the outside.
- Do not modify or tamper with the exhaust system.
- Do not idle the engine except as necessary.

For more information go to [www.P65warnings.ca.gov/diesel](http://www.P65warnings.ca.gov/diesel).

### **General**

This manual contains instructions for machine operation and maintenance.

The machine must be correctly maintained for maximal performance.

The machine should be kept clean so that any leakages, loose bolts and loose connections are discovered at as early a point in time as possible.

Inspect the machine every day, before starting. Inspect the entire machine so that any leakages or other faults are detected.

Check the ground under the machine. Leakages are more easily detected on the ground than on the machine itself.





**THINK ENVIRONMENT !** Do not release oil, fuel and other environmentally hazardous substances into the environment. Always send used filters, drain oil and fuel remnants to environmentally correct disposal.

This manual contains instructions for periodic maintenance, where maintenance after every 10 and 50 hours of operation can be performed by the machine operator. Other maintenance intervals must be carried out by accredited (Dynapac) service personnel.



Additional instructions for the engine can be found in the manufacturer's engine manual.

Specific maintenance and checks on diesel engines must be carried out by the engine supplier's certified personnel.

### **CE marking and Declaration of conformity**

(Applies to machines marketed in EU/EEC)

This machine is CE marked. This shows that on delivery it complies with the basic health and safety directives applicable for the machine in accordance with machinery directive 2006/42/EC and that it also complies with other regulations and directives applicable for this machine.

A "Declaration of conformity" is supplied with this machine, which specifies the applicable regulations and directives with supplements, as well as the harmonized standards and other regulations that are applied and according to the regulations must be declared in writing.



**Safety - General instructions**

(Also read the safety manual)



1. **The operator must be familiar with the contents of the OPERATION section before starting the roller.**
2. **Ensure that all instructions in the MAINTENANCE section are followed.**
3. **Only the operator is allowed to be on the roller. Remain seated at all times when operating the roller.**
4. **Never use the roller if it is in need of adjustment or repair.**
5. **Only ascend and descend the roller when it is stationary. Use the intended footsteps, grips and rails. Always use the three-point grip (both feet and one hand, or one foot and both hands) when ascending or descending the machine. Never jump down from the machine.**
6. **The ROPS (Roll Over Protective Structure) shall be used.**
7. **Drive slowly in sharp bends.**
8. **Avoid driving across slopes. Drive straight up or straight down the slope.**
9. **Never operate with roller outside the edge, if the substrate does not have full bearing strength or is close to a slope. Avoid operating close to edges and ditches and the like as well as on poor ground conditions that influence the bearing strength and capacity to support the roller.**
10. **Make sure that there are no obstacles in the direction of travel, on the ground, in front of or behind the roller, or overhead.**
11. **Drive particularly carefully on uneven ground.**
12. **Use the safety equipment provided. The seat belt must be worn on machines fitted with ROPS/ROPS-cab.**
13. **Keep the roller clean. Clean any dirt or grease that accumulates on the operator platform immediately. Keep all signs and decals clean and legible.**
14. **Safety measures before refueling:**
  - **Stop the engine**
  - **Do not smoke.**
  - **No naked flames in the vicinity of the roller.**
  - **Earth the filling equipment nozzle to the tank opening to avoid sparks.**
15. **Before repairs or service:**
  - **Chock the drums/wheels.**
  - **Lock the articulation if necessary.**
  - **Place blocks under overhanging equipment, such as strike-off blade and chip spreader.**

16. **Hearing protection is recommended if the noise level exceeds 80 dB(A). The noise level can vary depending on the equipment on the machine and the surface the machine is being used on.**
17. **Do not make any changes or modifications to the roller that could affect safety. Changes are only to be made after written approval has been given by Dynapac.**
18. **Avoid using the roller before the hydraulic fluid has reached its normal working temperature. Braking distances can be longer than normal when the fluid is cold. See instructions in the STOP section.**
19. **For your own protection always wear:**
  - helmet
  - working boots with steel toecaps
  - ear protectors
  - reflecting clothing/high visibility jacket
  - working gloves
20. **If the machine seems to be responding abnormally during travel, stop and check it.**

### Safety - when operating



**Prevent persons from entering or remaining in the danger area, i.e. a distance of at least 7 m (23 ft) in all directions from operating machines. The operator may allow a person to remain in the risk zone, however he/she must be attentive and operate the machine only when the person is fully visible or has given a clear indication of where he or she is.**



**Avoid driving across a slope. Drive straight up and down sloping ground.**

### Work driving

Avoid operating close to edges and ditches and the like as well as on poor ground conditions that influence the bearing strength and capacity to support the roller. Pay attention to potential obstacles above the machine, such as overhead cables and the branches of trees etc.

Pay particular attention to the stability of the substrate when compacting close to edges and holes. Do not compact with a large overlap from the previous track in order to maintain roller stability. Consider other compaction methods such as remote-control or a walk-behind roller close to steep slopes or where the bearing strength of the substrate is unknown.



**It is recommended that ROPS (Roll Over Protective Structure) or a ROPS-approved cab is always used when driving on slopes or unsafe ground. Always wear a seat belt.**

### Driving near edges

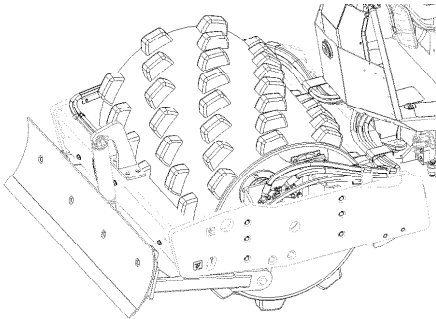


*Never operate with roller outside the edge, if the substrate does not have full bearing strength or is close to a slope.*



*Keep in mind that the machine's center of gravity moves outwards when steering. For example, the center of gravity moves to the right when you steer to the left.*

### Strike-off blade



*The operator must make sure that nobody is in the area of operation while the machine is in use.*



The strike-off blade must be retracted to the transport position at the end of each working period.

**Fig. Strike-off blade**

## Special instructions

### Standard lubricants and other recommended oils and fluids

Before leaving the factory, the systems and components are filled with the oils and fluids specified in the lubricant specification. These are suitable for ambient temperatures in the range -15°C to +40°C (5°F - 105°F).

 The maximum ambient temperature for biological hydraulic fluid is +35°C (95°F).

### Higher ambient temperatures, above +40°C (104°F)

For operation of the machine at higher ambient temperatures, however maximum +50°C (122°F), the following recommendations apply:

The diesel engine and hydraulic system can be run at this temperature using normal oil, but in other components that use transmission oil, Shell Spirax S3 AX85W/140, API GL-5 or equivalent must be used.

Other components that use transmission oil: Shell Spirax AX 85W/140 or equivalent.

### Temperatures


The temperature limits apply to standard versions of rollers.

Rollers equipped with additional equipment, such as noise suppression, may need to be more carefully monitored in the higher temperature ranges.

### High pressure cleaning

Do not spray directly onto electrical components.

 Do not use a high-pressure water jet on the instrument panel/display.

 Detergent that can destroy electrical parts, or which is conductive, must not be used.

Place a plastic bag over the fuel filler cap and secure with a rubber band. This is to avoid high pressure water entering the vent hole in the filler cap. This could

cause malfunctions, such as the blocking of filters.



Never aim the water jet directly at the fuel tank cap, or into exhaust pipe. This is particularly important when using a high-pressure cleaner.

### Fire fighting

If the machine catches fire, use an ABC-class powder fire extinguisher.

A BE-class carbon dioxide fire extinguisher can also be used.

### Roll Over Protective Structure (ROPS)



***Never carry out any welding or drilling operations of any kind on the Roll Over Protective Structure (ROPS).***



***Never attempt to repair a damaged ROPS structure. This must be replaced with new ROPS structure.***

### Battery handling



***When removing batteries, always disconnect the negative cable first.***



***When fitting batteries, always connect the positive cable first.***




Dispose of old batteries in an environmentally friendly way. Batteries contain toxic lead.



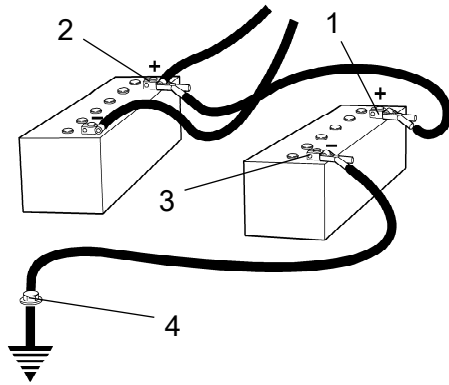
Do not use a quick-charger for charging the battery. This may shorten battery life.



### Jump starting

 **Do not connect the negative cable to the negative terminal on the dead battery. A spark can ignite the oxy-hydrogen gas formed around the battery.**

 **Check that the battery used for jump starting has the same voltage as the dead battery.**



**Fig. Jump starting**

Turn the ignition and all power consuming equipment off. Switch off the engine on the machine which is providing jump start power.

First connect the jump start battery's positive terminal (1) to the flat battery's positive terminal (2). Then connect the jump start battery's negative terminal (3) to, for example, a bolt (4) or the lifting eye on the machine with the flat battery.

Start the engine on the power providing machine. Let it run for a while. Now try to start the other machine. Disconnect the cables in the reverse order.



**Technical specifications****Vibrations - Operator station  
(ISO 2631)**

**The vibration levels are measured in accordance with the operational cycle described in EU directive 2000/14/EC on machines equipped for the EU market, with vibration switched on, on soft polymer material and with the operator's seat in the transport position.**

Measured whole-body vibrations are below the action value of 0.5 m/s<sup>2</sup> as specified in Directive 2002/44/EC. (Limit is 1.15 m/s<sup>2</sup>)

Measured hand/arm vibrations also were below the action level of 2.5 m/s<sup>2</sup> specified in the same directive. (Limit is 5 m/s<sup>2</sup>)

**Noise level**

**The noise level is measured in accordance with the operational cycle described in EU directive 2000/14/EC on machines equipped for the EU market, on soft polymer material with vibration switched on and the operator's seat in the transport position.**

Guaranteed sound power level, $L_{wA}$	103	dB (A)
Sound pressure level at the operator's ear (platform), $L_{pA}$	80 ±3	dB (A)

---

**During operation the above values may differ because of the actual operational conditions.**

**Electrical system**

**Machines are EMC tested in accordance with EN 13309:2000 'Construction machinery'**



Max 20° or 36%

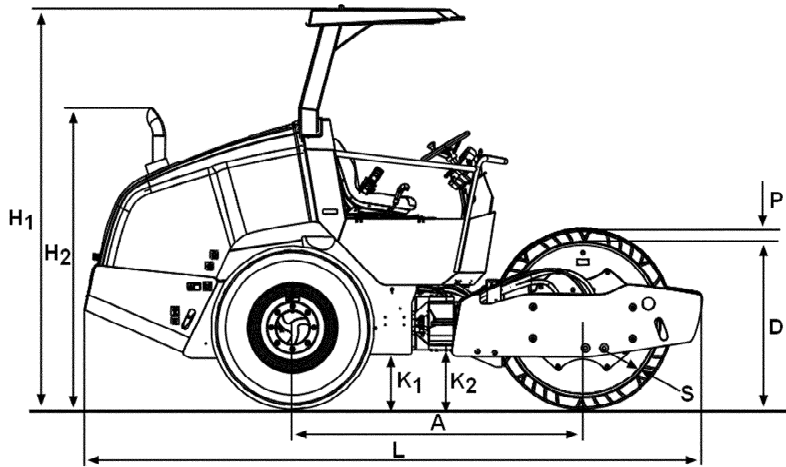
### Slopes

This angle has been measured on a hard, flat surface with the machine stationary.

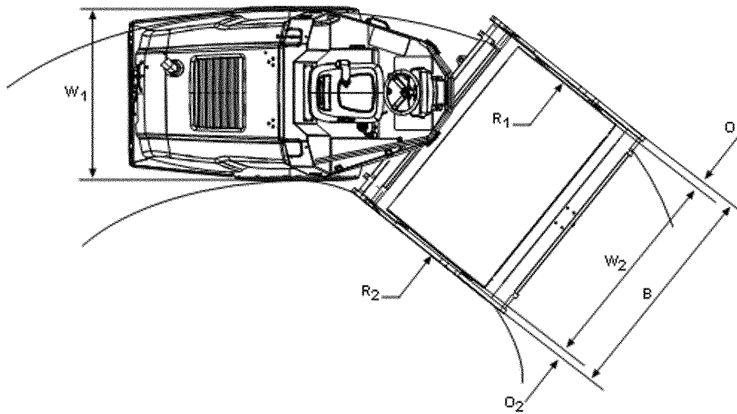
The steering angle was zero, the vibration was switched OFF and all tanks were full.

Always take into consideration that loose ground, steering the machine, vibration on, machine speed across the ground and raising the center of gravity can all cause the machine to topple at smaller slope angles than those specified here.

## Dimensions, side view



	Dimensions	mm	in
A	Wheelbase, drum and wheel	1860	73
L	Length, standard equipped roller (D)	3960	156
L	Length, standard equipped roller (PD)	3960	156
H <sub>1</sub>	Height with ROPS (D)	2565	101
H <sub>1</sub>	Height with ROPS (PD)	2565	101
H <sub>2</sub>	Height without ROPS (D)	1925	76
H <sub>2</sub>	Height without ROPS (PD)	1925	76
D	Diameter, drum	1000	39
S	Thickness, drum sweep, nominal	22	0.9
P	Height, pads (PD)	76	3
K <sub>1</sub>	Clearance, tractor frame (D)	350	13.7
K <sub>1</sub>	Clearance, tractor frame (PD)	350	13.7
K <sub>2</sub>	Clearance, drum frame (D)	260	10
K <sub>2</sub>	Clearance, drum frame (PD)	335	13.1

**Dimensions, top view**


	<b>Dimensions</b>	<b>mm</b>	<b>in</b>
B	Width, standard equipped roller	1495	59
O <sub>1</sub>	Overhang, left frame side	62	2.4
O <sub>2</sub>	Overhang, right frame side	62	2.4
R <sub>1</sub>	Turn radius, external	3890	153
R <sub>2</sub>	Turn radius, internal	2400	94
W <sub>1</sub>	Width, tractor section	1380	54
W <sub>2</sub>	Width, drum	1370	54

### Weights and volumes

#### Weights

Service weight with ROPS (EN500) (D)	5000 kg	11,025	lbs
Service weight with ROPS (EN500) (PD)	5200 kg	11,465	lbs
Service weight without ROPS (D)	4890 kg	10,780	lbs
Service weight without ROPS (PD)	5090 kg	11,225	lbs

#### Fluid volumes

Fuel tank	117 liters	31 gal
-----------	------------	--------

### Working capacity

#### Compaction data

Static linear load with ROPS (D)	12,9 kg/cm	72.2 pli
Static linear load with ROPS and Ballast weight (D)	15 kg/cm	84 pli
Static linear load, with ROPS (PD)	14,4 kg/cm	80.6 pli
Static linear load with ROPS and Ballast weight (PD)	16,4 kg/cm	91.8 pli
Amplitude (D)	1,72 mm	0,068 in
Amplitude (PD)	1,45 mm	0,057 in
Vibration frequency, amplitude	34,6 Hz	2076 vpm
Centrifugal force, amplitude (D/PD)	87 kN	19,575 lb

**Note: The frequency is measured at high revs. The amplitude is measured as the real value and not the nominal.**

#### Propulsion

Speed range	0-6	km/h	0-4	mph
Climbing capacity (theoretical)	55	%		

### General

#### Engine

Manufacturer/Model	Kubota V3307	Kubota V3307-CR-TE5B	Turbo diesel
Power (SAE J1995)	55 kW	55 kW	74 hp
Engine speed, idling	800 rpm	800 rpm	
Engine speed, working/transport	2200 rpm	2200 rpm	

#### CO<sub>2</sub>-emission

CO<sub>2</sub>-emissions measured according to applicable test cycle in Regulation (EU) 2016/1628.

Manufacturer/Model		Test-cycle	CO <sub>2</sub> -emission (g/kWh)
Kubota V3307-CR-TE5B	Stage V	NRTC	857.6
Kubota V3307-CR-TE5B	Stage V	NRSC	799.2

NRTC: Non-road transient test cycles.

NRSC: Non-road steady-state test cycles

#### Electrical system

Battery	12V 100Ah
Alternator	12V 70A
Fuses	See the Electrical system section - fuses

#### Tire

#### Tire dimensions

#### Tire pressure

Std-type	12,5-20	200 kPa (2,0kp/cm <sup>2</sup> ) (29 psi).
Tractor type	12,5-20	200 kPa (2,0kp/cm <sup>2</sup> ) (29 psi).



**The tires can as an option be filled with fluid (extra weight up to 85 kg/tire, 187 lbs/tire). When servicing, bear this extra weight in mind.**



### Tightening torque

Tightening torque in Nm for oiled or dry bolts tightened with a torque wrench.

Metric coarse screw thread, bright galvanized (fzb):

#### STRENGTH CLASS:

M - thread	8.8, Oiled	8.8, Dry	10.9, Oiled	10.9, Dry	12.9, Oiled	12.9, Dry
<b>M6</b>	8,4	9,4	12	13,4	14,6	16,3
<b>M8</b>	21	23	28	32	34	38
<b>M10</b>	40	45	56	62	68	76
<b>M12</b>	70	78	98	110	117	131
<b>M14</b>	110	123	156	174	187	208
<b>M16</b>	169	190	240	270	290	320
<b>M20</b>	330	370	470	520	560	620
<b>M22</b>	446	497	626	699	752	839
<b>M24</b>	570	640	800	900	960	1080
<b>M30</b>	1130	1260	1580	1770	1900	2100

Metric coarse thread, zinc-treated (Dacromet/GEOMET):

#### STRENGTH CLASS:

M - thread	10.9, Oiled	10.9, Dry	12.9, Oiled	12.9, Dry
<b>M6</b>	12,0	15,0	14,6	18,3
<b>M8</b>	28	36	34	43
<b>M10</b>	56	70	68	86
<b>M12</b>	98	124	117	147
<b>M14</b>	156	196	187	234
<b>M16</b>	240	304	290	360
<b>M20</b>	470	585	560	698
<b>M22</b>	626	786	752	944
<b>M24</b>	800	1010	960	1215
<b>M30</b>	1580	1990	1900	2360



ROPS-bolts which are to be torque tightened must be dry.

**ROPS - bolts**

Bolt dimensions :	M16 (4700500082)
Strength class :	8.8
Tightening torque :	190 Nm

**Hydraulic system**

<b>Opening pressure</b>	<b>MPa</b>
Drive system	41,5
Supply system	2,0
Vibration system	22,7
Control systems	10,0

<b>Release pressure</b>	<b>MPa</b>
Brake release	1.5

## **Machine description**

### **Diesel engine**

The machine is equipped with a four-cylinder, water-cooled diesel engine with direct injection.

The engine has an overlying camshaft and the cylinder head is shared by all the cylinders.

The engine is also equipped with a system for after-treatment of exhaust fumes (DPF Diesel Particle Filter).

### **Exhaust after-treatment system**

To minimize particles and hydrocarbons, the engine is fitted with a diesel particle filter, as well as a control unit for after-treatment of exhaust fumes. The diesel particle filter incorporates active burnout.

When the engine is running, particles are collected in the DPF, and the particles have to be burned away in order to clean the filter.

During the burnout/regeneration process, the exhaust gas temperature increases significantly above the normal temperature in the exhaust pipe.

### **Electrical system**

The machine has the following control units (ECU, Electronic Control Unit) and electronic units.

- Main ECU (for the machine)
- Diesel engine control unit (ECM)

### **Propulsion system/Transmission**

The propulsion system is a hydrostatic system with a hydraulic pump supplying two motors connected in parallel, one for the rear axle and one for the drum.

The speed of the machine is proportional to the angle of the control lever (the deflection of the forward/reverse lever regulates the speed). A flow divider is available as an option.

### **Brake system**

The brake system comprises a service brake, secondary brake and parking brake. The service brake system produces retardation of the propulsion system, i.e. hydrostatic braking.

### **Secondary/Parking brake**

The secondary and parking brake system consists of sprung multiple disc brakes in the rear axle and the drum drive, which are released by hydraulic pressure.

### Steering system

The control system is a mechanical-hydraulic system of the load-sensing type. The control valve on the steering column distributes the flow to the control cylinder at the articulation. The steering angle is proportional to the deflection of the steering wheel.

### Vibration system

The vibration system is a hydrostatic system in which a hydraulic motor drives the eccentric shaft, which generates the drum's vibrations.

The amplitude is determined by the direction of rotation of the hydraulic motor.

### FOPS and ROPS

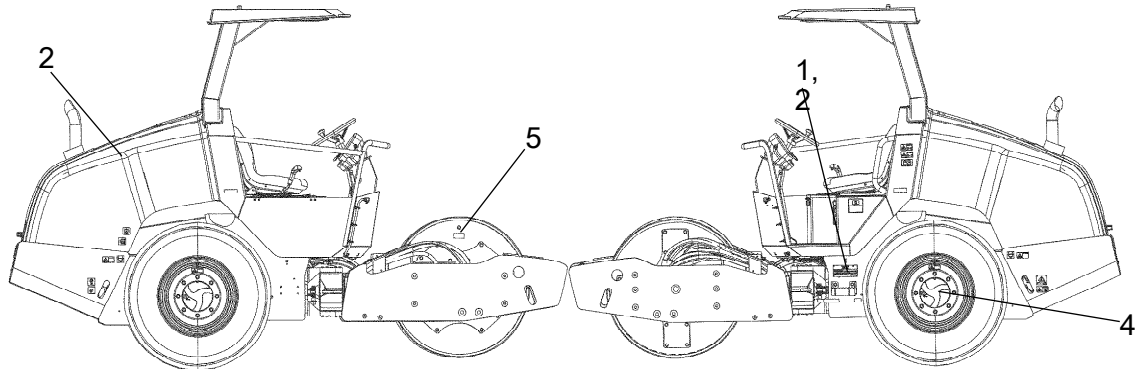
FOPS is the abbreviation for "Falling Object Protective Structure" (roof protection) and ROPS is the abbreviation for "Roll Over Protective Structure".

If any part of the protective construction on the cab or FOPS/ROPS structure reveals plastic deformation or cracking, the FOPS/ROPS structure must be replaced immediately.

Never undertake unauthorised modifications on the FOPS/ROPS structure without first having discussed the modification with Dynapac's production unit. Dynapac will resolve whether the modification would invalidate approval in line with FOPS/ROPS standards.

## Identification

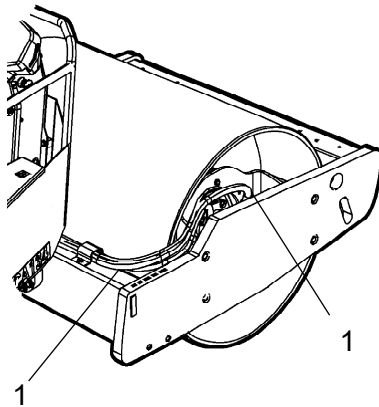
### Product and component plates



1. Product plate - Product Identification Number (PIN), model/type designation
2. Engine plate - Type description, product and serial numbers
4. Component plate, rear axle - Product and serial numbers
5. Component plate, drum - Product and serial numbers

### Product identification number on the frame

The machine PIN (product identification number) (1) is punched on the right edge of the front frame or the upper edge of the right frameside.



**Fig. Front frame**  
**1. PIN**

## Machine plate

The machine type plate (1) is attached to the front left side of the frame, beside the steering joint.

The plate specifies the manufacturer's name and address, the type of machine, the PIN product identification number (serial number), service weight, engine power and year of manufacture. (If the machine is delivered outside the EU there are no CE markings, and on some machines the year of manufacture may not be specified.)

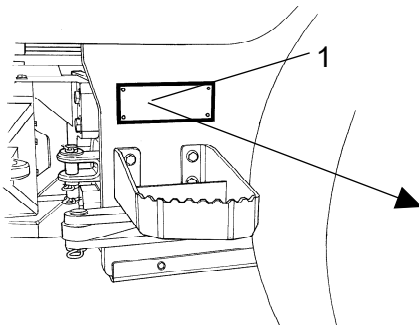





Fig. Operator platform  
1. Machine plate

					
Dynapac Compaction Equipment AB Box 504, SE-371 23 Karlskrona Sweden					
Product Identification Number		XXXXXXXXXXXXXXXXXX			
Designation	Type	Rated Power	Max axle load front / rear		
XXXXXX	XXXXXX	XXX kW	XXXX/XXXX kg		
Gross machinery mass		Operating mass	Max ballast	[Date of Mfg]	
XXXX kg		XXXX kg	XXXX kg	XXXX	
Made in Sweden					
<small>4811 0001 33</small>					

Please state the machine's PIN when ordering spares.

## Explanation of 17PIN serial number

- A= Manufacturer
- B= Family/Model
- C= Check letter
- F= Serial number

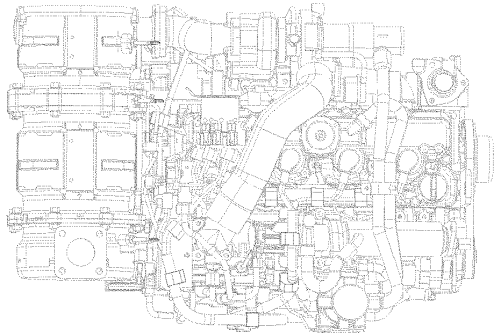
100	00123	V	x	A	123456
A	B	C	F		

**Engine plates**

The engine's type plate (1) is located on top of the cylinder head cover.

The plate specifies the type of engine, its serial number and the engine specification.

**Please specify the engine serial number when ordering spares. Refer also to the engine manual.**



**Fig. Engine**  
**1. Type plate**

TYPE :	#####
FAMILY :	#####
APPROVAL NUMBER:	###/###/#####
<b>Kubota</b> KUBOTA Corporation	
	####

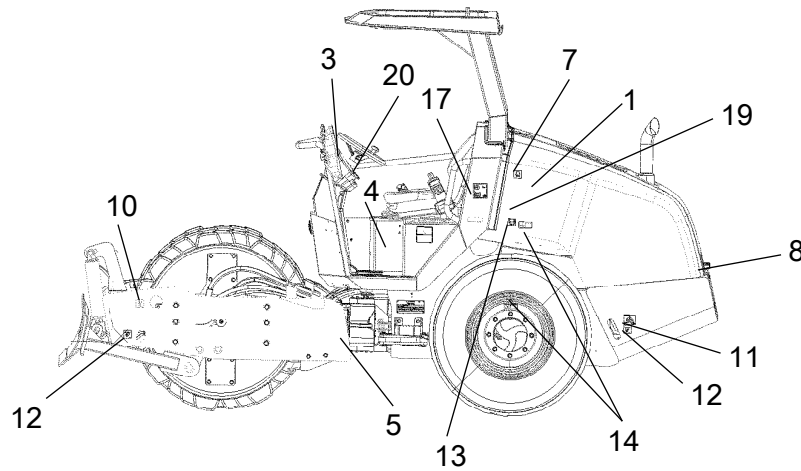
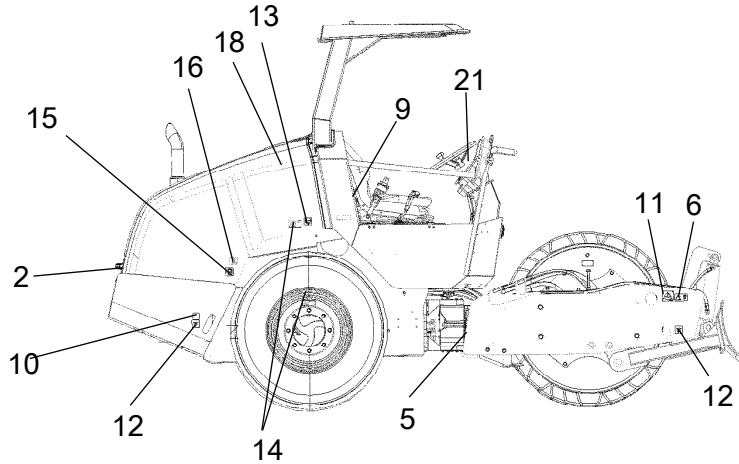
EMISSION CONTROL INFORMATION <span style="float: right;">/</span>	
THIS ENGINE MEETS 2012 ##### EMISSION REGULATIONS FOR U.S. EPA AND CALIFORNIA NONROAD ENGINES.	
<b>Kubota</b> KUBOTA Corporation	
MODEL :	##### ENGINE DISP. : #####
FAMILY :	C #####
POWER :	## kW / ### rpm CATEGORY: ## - ## kW
VALVE CLEARANCE (COLD):	IN ## mm EX ## mm
EDS:	### #####
ULTRA LOW SULFUR DIESEL FUEL ONLY	
DEL. ASSY:	#####





Machine description- Decals

Location - decals



1. Diesel fuel	4811000345	8. Warning, Hot surfaces	4700903424	15. Hydraulic fluid level	4700272373
2. Warning, Rotating engine components	4700903423	9. Battery master switch	4700904835	Biological hydraulic fluid	4700792772
3. Warning, Read instruction manual	4700903459	10. Lift point	4700357587	Sound power level	4700791273
4. Handbook compartment	4700903425	11. Hoisting plate	4700904870	Warning, Starting gas	4700791642
5. Warning, Crush zone	4700903422	12. Tie down point	4700382751	19. Fuel with a low sulphur content	4811000344
6. Warning, Locking	4700908229	13. Tire pressure	4700355983	20. Starting instructions	4812115918
7. Coolant	4700388449	Warning, Ballasted tires	4700903985	21. Warning lamps	4812117993

Location - decals, CALIFORNIA

Proposition 65

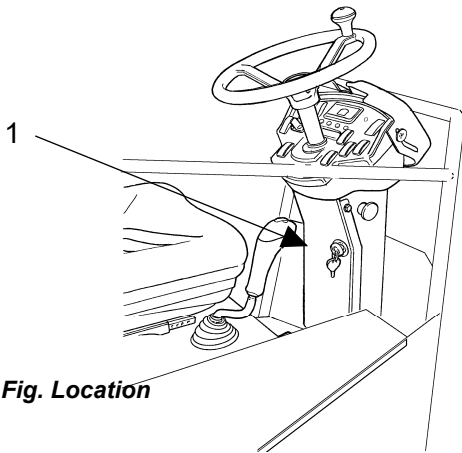
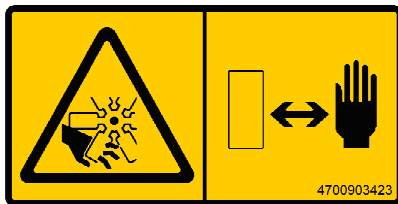


Fig. Location

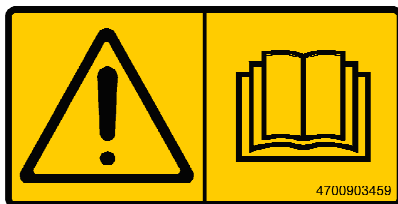
- 1. Warning, CALIFORNIA Proposition 65 4812129673

Safety decals

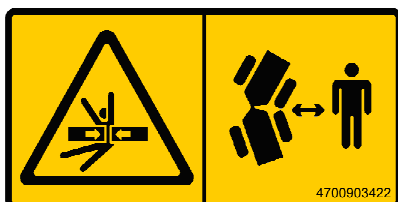
Always make sure that all safety decals are completely legible, and remove dirt or order new decals if they have become illegible. Use the part number specified on each decal.



- 4700903423**  
Warning - Rotating engine components.  
Keep your hands at a safe distance.



- 4700903459**  
Warning - Instruction manual  
The operator must read the safety, operation and maintenance instructions before operating the machine.



- 4700903422**  
Warning - Crush zone, articulation/drum.  
Maintain a safe distance from the crush zone.

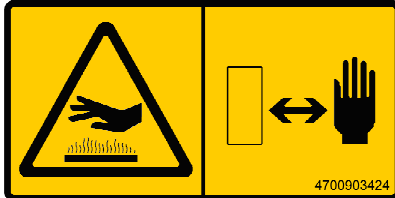


**4700908229**

**Warning - Risk of crushing**

The articulation must be locked when lifting.

Read the instruction manual.



**4700903424**

**Warning - Hot surfaces in the engine compartment.**

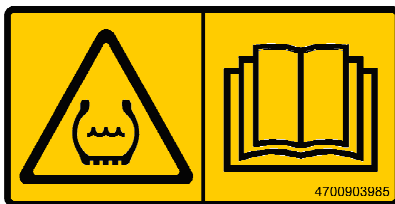
Keep your hands at a safe distance.



**4700791642**

**Warning - Starting gas**

Starting gas is not to be used.



**4700903985**

**Warning - Ballasted tire.**

Read the instruction manual.

More information in section in Technical specifications.

4812129673  
Warning

CALIFORNIA - Proposition 65



# WARNING

Breathing diesel engine exhaust exposes you to chemicals known to the State of California to cause cancer and birth defects or other reproductive harm.

- Always start and operate the engine in a well-ventilated area.
- If in an enclosed area, vent the exhaust to the outside.
- Do not modify or tamper with the exhaust system.
- Do not idle the engine except as necessary.

For more information go to  
[www.P65warnings.ca.gov/diesel](http://www.P65warnings.ca.gov/diesel)

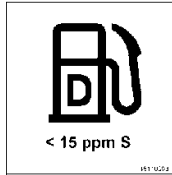
4812129673

Info decals

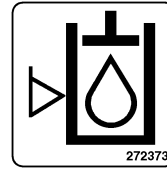
**Fuel with a low sulphur content**



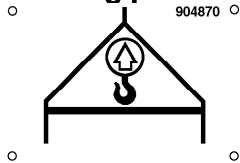
**Diesel fuel**



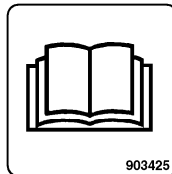
**Hydraulic fluid level**



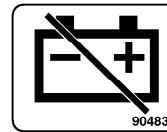
**Hoisting plate**



**Handbook compartment**



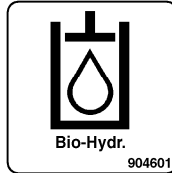
**Master switch**



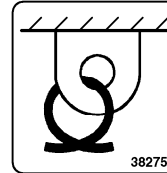
**Hydraulic fluid**



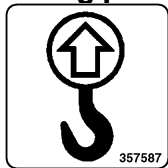
**Biological hydraulic fluid**



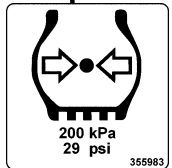
**Tie down point**



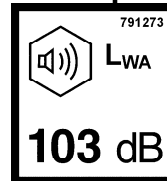
**Lifting point**



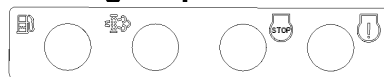
**Tire pressure**



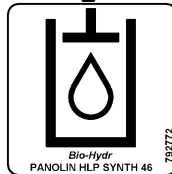
**Sound power level**



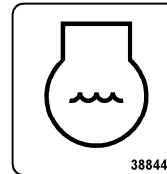
**Warning lamps**



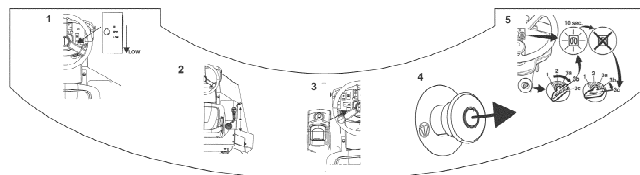
**Biological hydraulic fluid**



**Coolant**

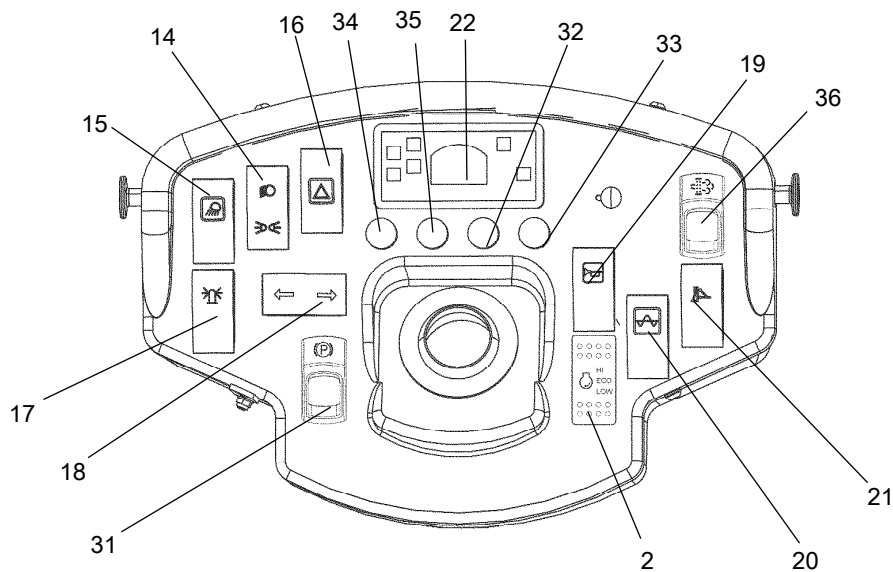


**Starting instructions**



## Instruments/Controls

### Locations - Instruments and controls

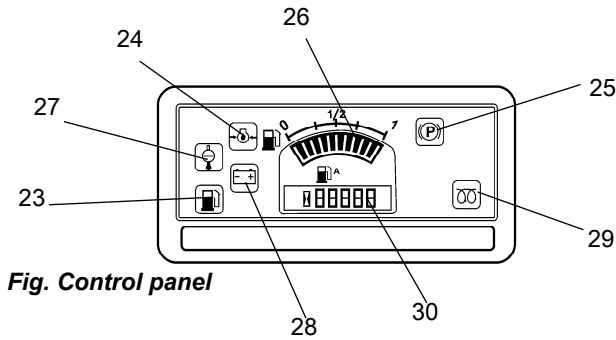


**Fig. Instruments and control panel**

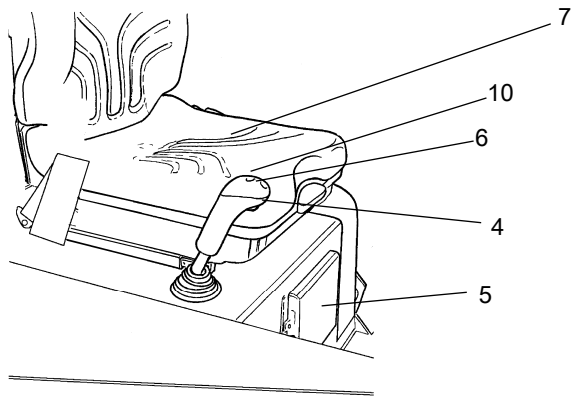
- |     |                           |     |  |
|-----|---------------------------|-----|--|
| 2.  | Speed selector, LO/ECO/HI | 20. | Vibration ON/OFF                                   |
| 14. | Driving lights *          | 21. | Strike-off blade *                                 |
| 15. | Working lights *          | 22. | Control panel                                      |
| 16. | Hazard lights *           | 31. | Parking brake On/Off                               |
| 17. | Rotating beacon *         | 32. | Motor diagnostics control light serious fault      |
| 18. | Direction indicator *     | 33. | Motor diagnostics control light less serious fault |
| 19. | Horn                      | 34. | Control lamp, water separator                      |
|     |                           | 35. | Control lamp, parked regen                         |
|     |                           | 36. | Switch, parked regen                               |

\*) Depending on machine equipment status.

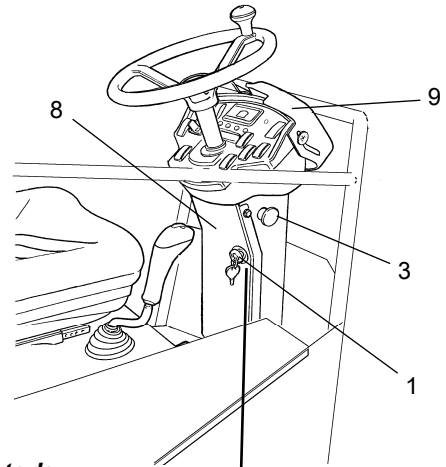
**Locations - Control panel and controls**



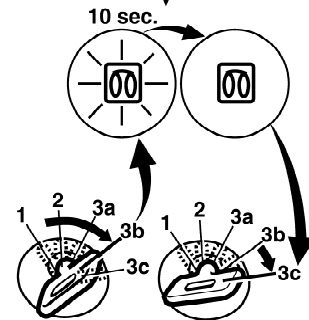
**Fig. Control panel**



**Fig. Operator position**


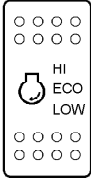







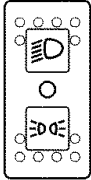


**Fig. Operator's station**



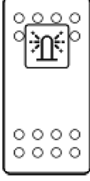

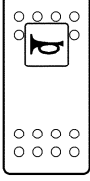

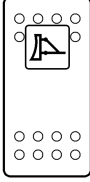













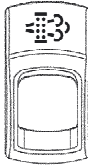
- |    |                       |    |                           |
|----|-----------------------|----|---------------------------|
| 1  | Starter switch        | 23 | Low fuel level            |
| 3  | Emergency stop        | 24 | Oil pressure, engine      |
| 4  | Vibration On/Off      | 25 | Parking brake             |
| 5  | Handbook compartment  | 26 | Fuel level                |
| 6  | Forward/reverse lever | 27 | Water temperature, engine |
| 7  | Seat switch           | 28 | Battery/charging          |
| 8  | Fuse box              | 29 | Glow plug                 |
| 9  | Instrument cover      | 30 | Hourmeter                 |
| 10 | Strike-off blade      |    |                           |

### Function description

No	Designation	Symbol	Function
1.	Starter switch		<p>Positions 1-2: Shut off position, key can be removed.</p> <p>Position 3a: All instruments and electric controls are supplied with power.</p> <p>Position 3b: Glowing. Hold the starter switch in this position until the lamp goes out. The starter motor is activated in the next position.</p> <p>Position 3c: Starter motor activation.</p>
2.	Electronic speed control regulator		<p>Three-position switch for idling (LO), fuel economy (ECO) and working speed (HI). <b>NOTE:</b>The lever must be in neutral (LO) when starting the machine. The engine also runs at low speed when stationary for more than about 10 seconds if the F&amp;R lever is in neutral. If the F&amp;B lever is moved out of neutral, the speed returns to the set speed again.</p>
3.	Emergency stop		<p>When pressed, the emergency stop is activated. The brake is applied and the engine stops. Brace yourself for a sudden stop.</p>
4.	Vibration On/Off. Switch		<p>Press once and release to switch vibration on. Press again to switch the vibration off.</p>
5.	Handbook compartment		<p>Pull up and open the top of the compartment for access to handbooks.</p>
6.	Forward/Reverse lever		<p>The lever must be in neutral to start the diesel engine. The engine cannot be started if the lever is in any other position.</p> <p>The forward/reverse lever controls both the roller's driving direction and speed. When the lever is moved forward, the roller moves forward etc. The roller's speed is proportional to the distance the lever is from the neutral position. The further the lever is from the neutral position, the higher the speed.</p>
7.	Seat switch		<p>Remain seated at all times when operating the roller. If the operator stands up during operation, a buzzer sounds. After 3 seconds the brakes are activated and the engine stops.</p>
8.	Fuse box (on control column)		<p>Contains fuses for the electrical system. See under the heading 'Electrical system' for a description of fuse functions.</p>
9.	Instrument cover		<p>Lowered over the instrument plate to protect the instruments from the weather and sabotage. Lockable</p>
14.	Road lights, switch		<p>Where the upper position is depressed, the road lights are on. Where the lower position is, depressed the parking lights are on.</p>



No	Designation	Symbol	Function
15.	Working lights, switch		When depressed, the working lights are on
16.	Hazard warning lights, switch		Where depressed, the hazard warning lights are on
17.	Hazard beacon, switch		Where depressed, the hazard beacon is on
18.	Direction indicators, switch		When depressed to the left, the left direction indicators are on etc. In the middle position the function is shut off.
19.	Horn, switch		Press to sound the horn.
20.	Vibration, switch		Activates the vibration together with the switch in the forward/reverse lever.
21.	Strike-off blade, On/Off, switch		When pressed, the strike-off blade is activated. Controls the position of the strike-off blade.
22.	Control panel		
23.	Warning lamp, low fuel level		The lamp comes on when the fuel level in the tank is low.
24.	Warning lamp, oil pressure		This lamp lights if the lubricating pressure in the engine is too low. Stop the engine immediately and locate the fault.
25.	Warning lamp, parking brake		The lamp lights when the parking brake is activated.
26.	Fuel level		Shows the fuel level in the diesel tank.
27.	Warning lamp, water temperature		The light comes on if the water temperature is too high.
28.	Warning lamp, battery charging		If the lamp lights while the engine is running the alternator is not charging. Stop the engine and locate the fault.

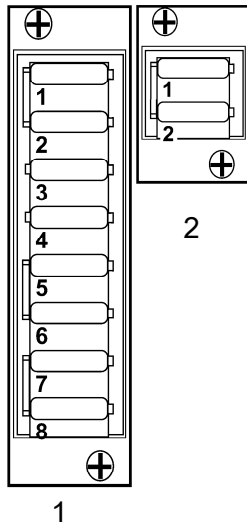
No	Designation	Symbol	Function
29.	Warning lamp, glow plug		The lamp must go out before the starter switch is moved to position 3c for activation of the starter motor.
30.	Hourmeter		Shows the number of hours the engine has run.
31.	Parking brake On/Off, switch		To activate the brakes, press the top of the switch to change the position of the lever. To disengage the brakes, press down the red part at the same time as the switch, and change the position of the lever. NOTE: When starting the machine, the parking brake must be activated.
32.	Motor diagnostics		Control lamp red. Serious fault: Turn the motor off at once! Attend to before restarting.
33.	Motor diagnostics		Control lamp yellow. Less serious fault: Attend to as soon as possible.
34.	Water separator		Yellow control lamp. If the lamp goes on this means that there is water in the tank. Stop the roller and drain the fuel filter.
35.	Regen parked		Yellow control lamp. If the lamp flashes, start a parked regen.
36.	Regen parked, Switch		Parked regen is activated in pressed mode. If the indicator in the switch flashes, start a parked regen.

## Electrical system

### Fuses

The figure shows the position of the fuses.

The table below gives fuse amperage and function. All fuses are flat pin fuses.



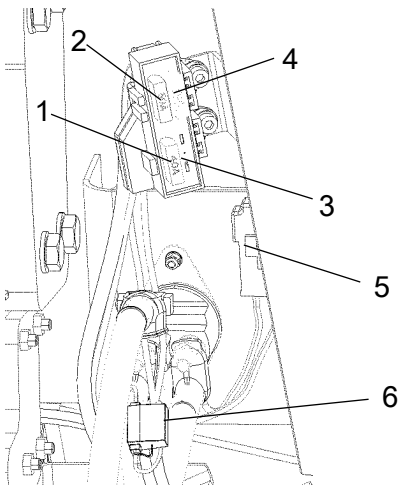
**Fig. Fuse boxes**  
 1. Upper  
 2. Lower

Fuse box, Upper		Fuse box, Lower	
1.	Emergency stop, ECU, Backup alarm, Neutral position, Seat switch, Vibration	15A	1. Traffic lights 20A
2.	Horn, Summer, Instrument panel	10A	2. Position lights 10A
3.	Hazard beacon, Strike off blade	10A	
4.	Working lights	20A	
5.	Engine ECU	5A	
6.	Alternator, Indication, Preheater	5A	
7.	EGR valve	5A	
8.	Reserve		

### Main fuses

There is one main fuse (2). It is located behind the battery disconnecter, on the right side inside the engine hood.

The fuse is of the flat pin type.



**Fig. Engine compartment**

- 1. Fuse, starter relay (40A)(F4.4)
- 2. Main fuse (50A) (F4.1)
- 3. Reserve
- 4. Fuse, preheating relay (80A) (F4.2)
- 5. Fuse, engine ECU (20A) (F8)
- 6. Fuse, 12V socket (10A) (F5)

Relays on machine

Control column

- |    |     |                 |
|----|-----|-----------------|
| 1. | K9  | Position lights |
| 2. | K10 | Stop lights     |

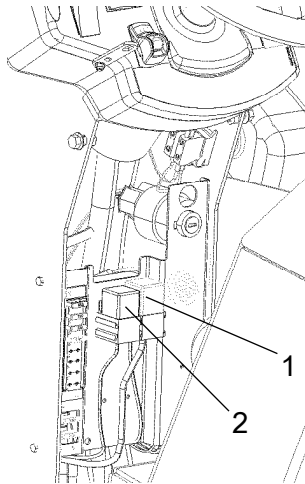


Fig. Relays Control column

Engine room

- |    |     |                        |
|----|-----|------------------------|
| 1. | K1  | Starting               |
| 2. | K2  | ECU                    |
| 3. | K5  | Preheating             |
| 4. | K24 | Preheating /<br>Lights |

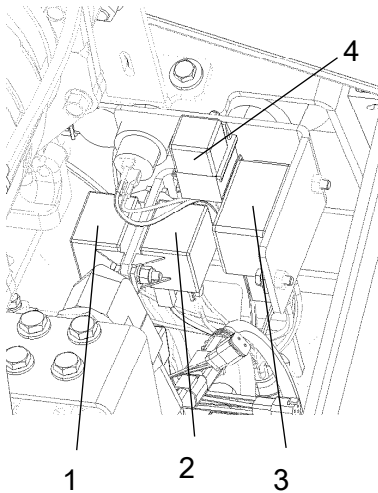
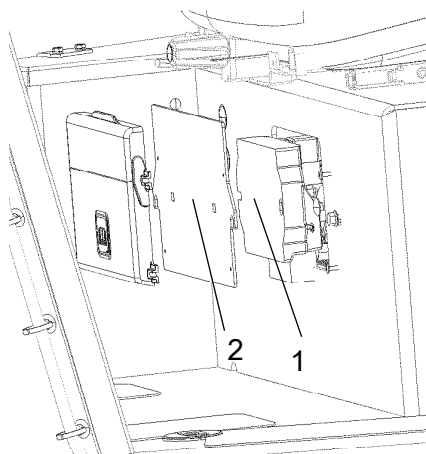


Fig. Relays Engine room



The control unit (ECU) (1) is located behind the cover (2) under the operator seat.

This control unit looks after the electrical drive control, including vibration, start-stop.

**Fig. Operator station**  
**1. Control unit (ECU)**  
**2. Cover**

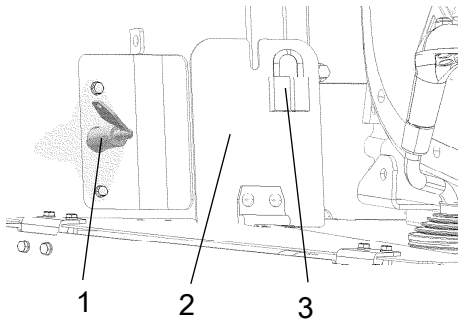
## Operation

### Before starting

#### Master switch - Switching on

Remember to carry out daily maintenance. Refer to the maintenance instructions.

The master switch is located on the right side of the operator platform. Turn the key (1) to the On position. The roller is now supplied with power.



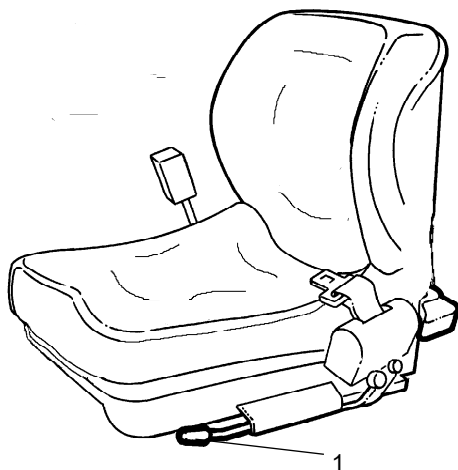
**Fig. Master switch**

- 1. Key
- 2. Cover
- 3. Padlock

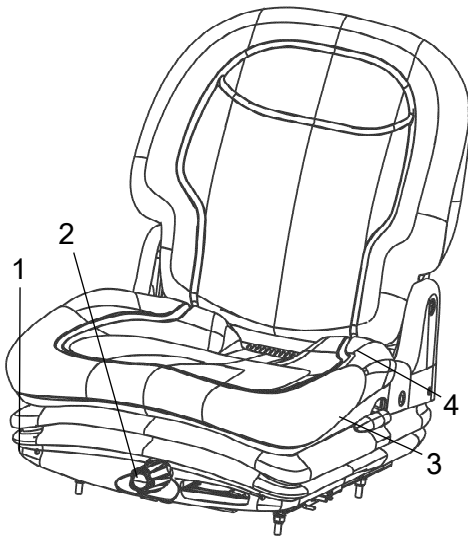
#### Operator's seat - Adjusting

Adjust the operator's seat so that the position is comfortable and so that the controls are within easy reach.

The seat can be adjusted lengthways (1).



**Fig. Operator's seat**  
1. Length adjustment



**Fig. Driver seat**  
1. Lock lever - Length adjustment  
2. Weight adjustment  
3. Back support angle  
4. Seat belt

### Driver seat (Equipment status) - Adjustment

Adjust the operator's seat so that the position is comfortable and so that the controls are within easy reach.

The seat can be adjusted as follows.

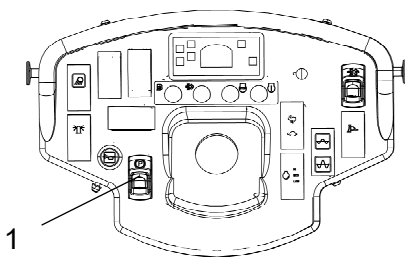
- Length adjustment (1)
- Weight adjustment (2)
- Back support angle (3)



**Always make sure that the seat is secure before beginning operation.**



**Do not forget to use the seat belt (4).**



**Fig. Control panel**  
1. Parking brake

### Parking brake



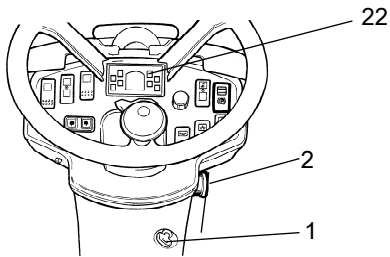
**Ensure that the parking brake (1) is definitely switched on.**

Brake is always activated in Neutral position.  
(automatic 1.5 sec.)

**The parking brake must be activated to start the machine!**



## Instruments and lamps - Checking



**Fig. Instrument panel**  
**1. Starter switch**  
**2. Emergency stop**  
**22. Warning panel**



**Make sure that the emergency stop (2) is pulled out. When the roller is in neutral or there is no load on the operator seat, the automatic brake function is engaged.**

Pull out the emergency stop (2).

Turn the switch (1) to position 3a.

Check that the warning lamps in the warning panel (22) come on.

## Interlock

The roller is equipped with Interlock.

The diesel engine will switch off after 4 seconds if the operator gets off the seat when going forwards/backwards.

If the control is in neutral when the operator stands up a buzzer will go on until the parking brake is activated.

If the parking brake is activated, the diesel engine will not stop if the forward/reverse lever is moved out of neutral.

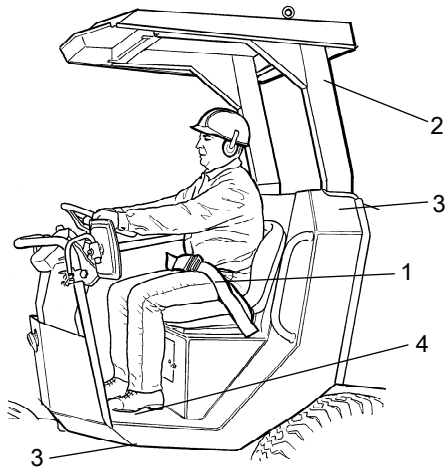
The diesel engine will switch off immediately if for any reason the forward/reverse lever is moved out of neutral when the operator is not sitting down and the parking brake has not been activated.



**Sit down for all operations!**

### Operator position

If a ROPS (2) (Roll Over Protective Structure) is fitted on the roller, always wear the seat belt (1) provided and wear a protective helmet.



**Fig. Driver's seat**  
1. Seat belt  
2. ROPS  
3. Rubber element  
4. Anti-slip



**Replace the seat belt (1) if it shows signs of wear or has been subjected to high levels of force.**



**Check that the rubber elements (3) on the platform are intact. Worn elements will impair comfort.**

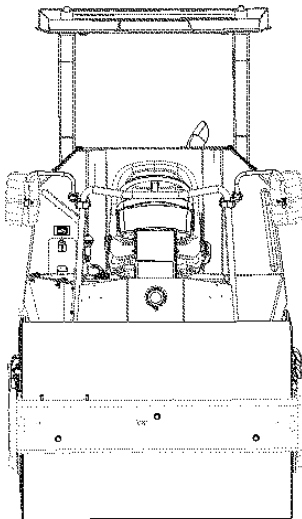


**Ensure that the anti-slip (4) on the platform is in good condition. Replace where anti-slip friction is poor.**

### View

Before starting, make sure that the view forwards and backwards is unobstructed.

The rear view mirrors (depending on roller equipment status) should be adjusted for a good rear view.



**Fig. view**

## Starting

### Starting the engine

Make sure that the emergency stop (3) is pulled out and the parking brake (31) is activated.

Set the forward/reverse lever (6) in neutral. The engine can only be started when the lever is in neutral.

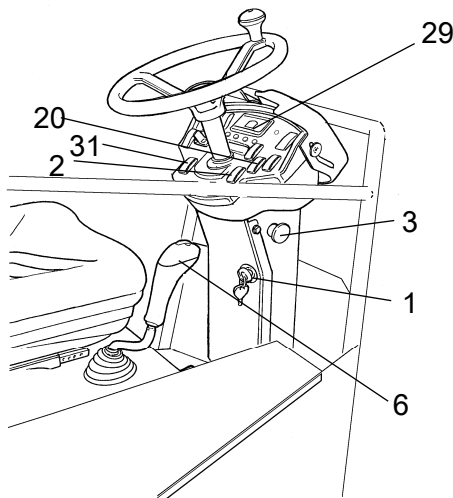
Turn the vibration switch (20) to the Off position (position O).

In the event of high external temperature, set the speed control (2) in idling position: Low.

Preheating: Turn the key to position II. When the glow lamp (29) goes off, after about 10 seconds, turn the starter switch (1) to position 3c. Release the starter as soon as the engine has started.



Do not run the starter motor for too long. If the engine does not start, wait a minute or so before trying again.



**Fig. Control panel**

- 1. Starter switch**
- 2. Engine speed control**
- 3. Emergency brake**
- 6. Forward/Reverse lever**
- 20. Vibration switch**
- 29. Glow lamp**
- 31. Parking brake**

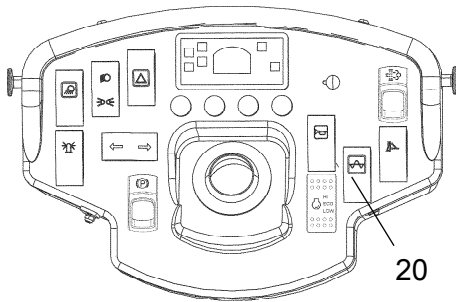


Fig. Instrument panel  
20. Vibration switch

Check while warming the engine that the warning lamps for the oil pressure (24) and charging (28) go out.

The warning lamp (25) should remain on.



**When starting and driving a machine that is cold, remember that the hydraulic fluid is also cold and that braking distances can be longer than normal until the machine reaches the working temperature.**



**Ensure that there is good ventilation (air extraction) if the engine is run indoors. Risk of carbon monoxide poisoning.**

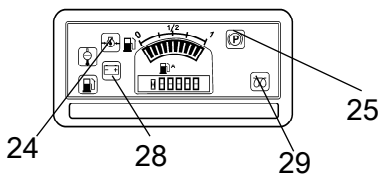

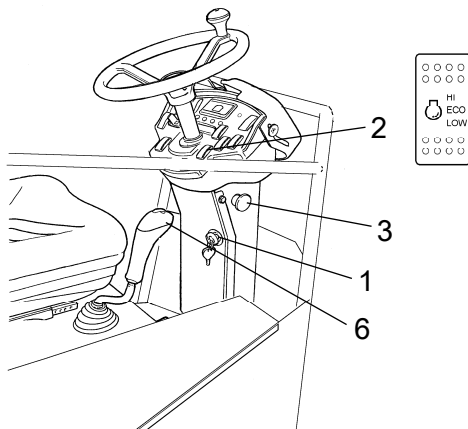


Fig. Control panel  
28. Charging lamp  
24. Oil pressure lamp  
25. Brake lamp  
29. Glow plug lamp

## Driving

### Operating the roller

 **Under no circumstances is the machine to be operated from the ground. The operator must be seated inside the machine during all operation.**



**Fig. Instrument panel**

- 1. Starter switch**
- 2. Engine speed control**
- 3. Emergency stop**
- 6. Forward/Reverse lever**


Set the speed control (2) in working position: High or Eco.

Check that the steering is working correctly by turning the steering wheel once to the right and once to the left while the roller is stationary.

 **Make sure that the area in front of and behind the roller is clear.**

Carefully move the forward/reverse lever (6) forwards or backwards, depending on which direction of travel is required.

The speed increases as the lever is moved away from the neutral position.

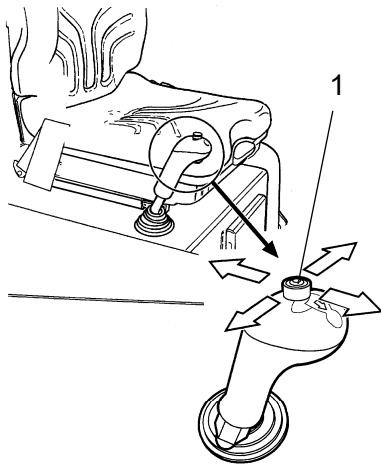
 **Test the emergency stop by pressing the emergency stop button (3) while the roller is moving slowly forward. Brace yourself for a sudden stop. The engine will be switched off and the brakes activated.**

Check while driving that the warning lamps have not gone on.

### Operation of strike-off blade (Equipment status)



**Before driving, make certain that the blade is in its uppermost position (raised). Inspect the condition of the ground before using the blade.**



**Fig. Forward/reverse lever  
1. Joystick, strike-off blade**

The joystick (1) has five positions.

Middle - Neutral.

Back - Lifting of blade.

Forward - Lowering of blade.

Tilting - Right/Left (Equipment status)

Lower the blade to the ground before leaving or parking the roller.



**Use the blade only when driving FORWARD.**

### Interlock/Emergency stop/Parking brake - Check



**The interlock, emergency stop and parking brake must be checked daily before operating. A function check of the interlock and emergency stop requires a restart.**



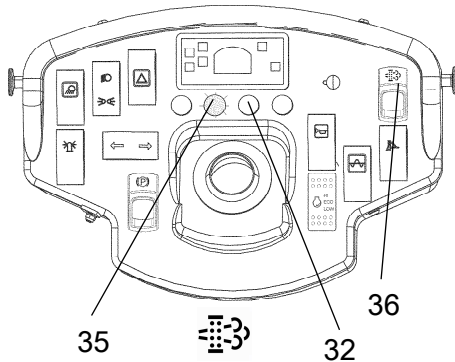
**The interlock function is checked by the operator standing up from the seat when the roller is moving very slowly forwards/backwards. (Check in both directions). Hold the steering wheel firmly and brace yourself for a sudden stop. A buzzer goes on and after 4 seconds the engine switches off and the brakes are activated.**



**Check the function of the emergency stop by pressing the emergency stop when the roller is moving slowly forwards/backwards. (Check in both directions). Hold the steering wheel firmly and brace yourself for a sudden stop. The engine switches off and the brakes are activated.**



**Check the function of the parking brake by activating the parking brake when the roller is moving very slowly forwards/backwards. (Check in both directions). Hold the steering wheel and brace yourself for a sudden stop when the brakes are activated. The engine does not switch off.**



**Fig. Control panel**  
**32. Control lamp, serious fault**  
**35. Control lamp, parked burnout**  
**36. Switch for parked regen of DPF filter**

## Burnout of DPF filter

The machine is equipped with a diesel particle filter (DPF filter).

The diesel engine does an automatic burnout of carbon when necessary and no indication is shown during normal operation.

If the machine is run frequently with partial load, starting and stopping, and at low temperatures etc., a **parked** regen may need to be done.

This is indicated when the lamp for **Parked Regen Requested** (35) starts flashing parallel to the switch (36).

The operator should park the machine at a suitable place and allow the engine to run.

The parking brake should be activated, the machine should be stationary, and the control lever should be in neutral.

The engine should be warm.

To start the parked regen, press the switch for **Parked Regen Requested** (36).

This is done by moving up the yellow lock and pressing the switch. The switch will spring back afterwards.

The speed of the engine increases and the lamp stops flashing but stays on, **Parked Regen Occuring** (35).

The regen of the DPF filter takes about 20 minutes, after which the engine returns to low speed and the lamp goes off.

When the regen is finished and if the machine is going to be used again, disable the parking brake.

The machine can now be used.

If it is not possible to do a parked regen, because the place is not suitable or because the working conditions will not permit this, do as follows:

- Drive the roller as soon as possible to a suitable place.
- Park the roller, enable the parking brake and carry out a parked regen.



**If the yellow flashing indicators on parked regen (35, 36) are ignored, error codes will be displayed and the engine power will be reduced. If the indicators continue to be ignored the red control lamp (32) will go on. Switch off the engine immediately, enable the parking brake and contact a service technician at once.**



**The free space over the roller must not be less than the height of the ROPSens. Temperatures of up to 350°C (662°F) can be generated at the exhaust pipe during a regen of the DPF filter.**



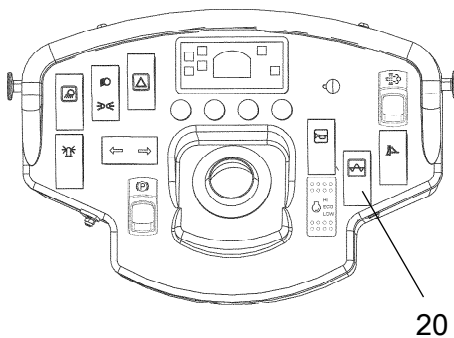
**The engine hood should be kept closed while the regen is in progress.**

## Vibration

### Vibration On/Off

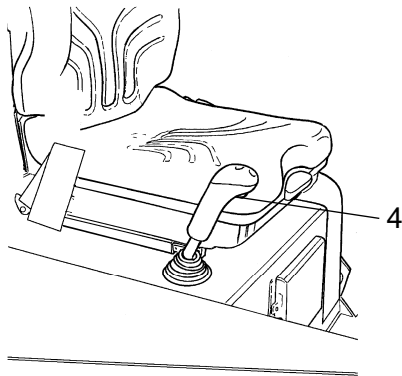
Activation/deactivation of the vibration is selected with the switch (20).

The operator must activate the vibration via the switch (4) on the underside of the forward/reverse handle. See illustration below.



**Fig. Instrument panel  
20. Vibration switch.**





**Fig. Forward/Reverse lever**  
4. Switch, vibration On/Off

## Vibration - Activation



Never activate vibration when the roller is stationary. This can damage both the surface and the machine.

Engage and disengage vibration using the switch (4) on the underside of the forward/reverse lever.

Always switch off vibration before the roller comes to a standstill.

## Braking

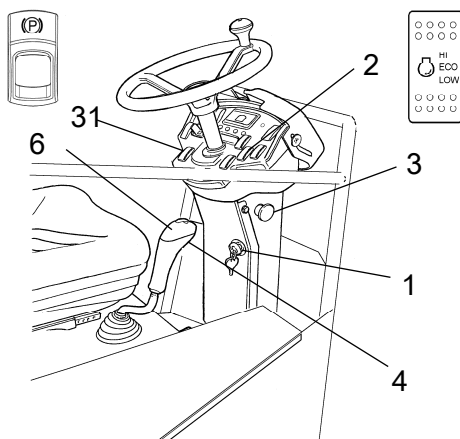
### Normal braking

Press the switch (4) to switch off the vibration.

Move the forward/reverse lever (6) to the neutral position to stop the roller.

Set the speed control (2) to idling position: Low.

Set the parking brake switch (31) in the On position.



**Fig. Instrument panel**

- 1. Key
- 2. Engine speed control
- 3. Emergency stop
- 4. Vibration On/Off
- 6. Forward/reverse lever
- 31. Parking brake



**Always use the parking brake (31) when the machine is stationary on a sloping surface.**



**When starting and driving a machine that is cold, remember that the hydraulic fluid is also cold and that braking distances can be longer than normal until the machine reaches the working temperature.**

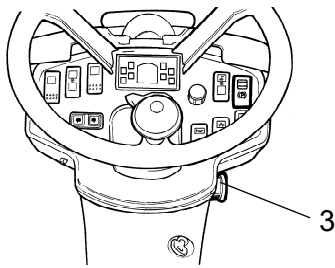


Fig. Instrument panel  
3. Emergency stop

### Emergency braking

Braking is normally activated using the forward/reverse lever. The hydrostatic transmission brakes the roller when the lever is moved towards the neutral position.

There is also a brake in the drum motor and rear axle that acts as an emergency brake during operation.



**For emergency braking, press the emergency stop (3), hold the steering wheel firmly and be prepared for a sudden stop. The brakes are applied and the engine stops.**

After emergency braking, return the forward/reverse lever to neutral and pull out the emergency stop (3).

Enable the parking brake (31) and set the speed control (2) to Low.

The roller is equipped with an Interlock and therefore the operator must sit in the seat to start the engine.

### Switching off

Check instruments and warning lamps to see if any faults are indicated. Switch off all lights and other electrical functions.

Turn the starter switch (1) to the left to switched off position 1. At the end of the shift, lower the instrument cover (22) and lock it.

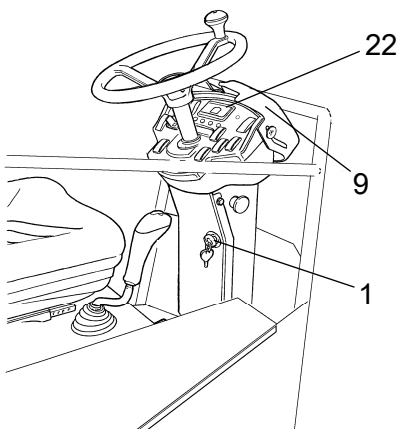


Fig. Instrument panel  
1. Starter switch  
9. Instrument guard  
22. Panel for warning lamps

## Parking

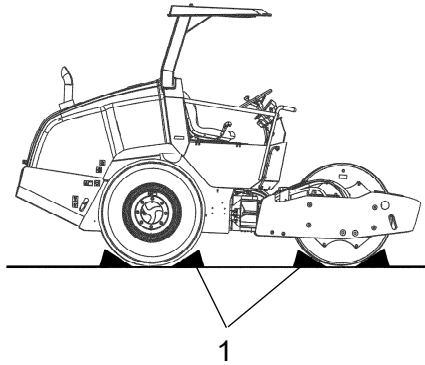
### Chocking the drums



**Never leave the roller when the engine is running without enabling the parking brake.**



**Make sure that the roller is parked in a safe place with respect to other road users. Chock the drums if the roller is parked on sloping ground.**

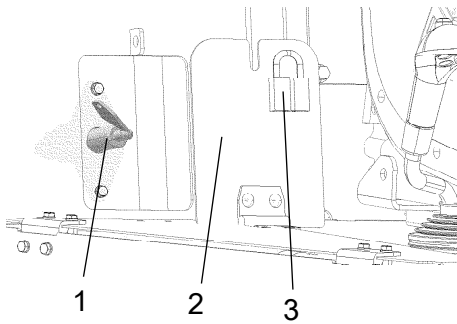


**Fig. Arrangement**  
**1. Chock**

### Master switch

Before leaving the roller for the day, switch the master switch (1) to the disconnected position and remove the handle.

This will prevent the battery discharging and will also make it difficult for unauthorized persons to start and operate the machine. Lock also the cover for the master switch.

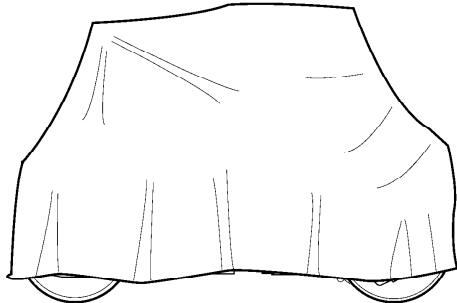


**Fig. Master switch**  
**1. Key**  
**2. Cover**  
**3. Padlock**



## Long-term parking

 The following instructions should be followed when long term parking (more than one month).



**Fig. Roller weather protection**

These measures apply when parking for a period of up to 6 months.

Before re-commissioning the roller, the points marked with an asterisk \* must be returned to the pre-storage state.

Wash the machine and touch up the paint finish to avoid rusting.

Treat exposed parts with anti-rust agent, lubricate the machine thoroughly and apply grease to unpainted surfaces.

### Engine

\* Refer to the manufacturer's instructions in the engine manual that is supplied with the roller.

### Battery

\* Remove the battery from the machine, clean, grease the cable connectors (terminals) and trickle charge the battery once a month. The battery is otherwise maintenance free.

### Air cleaner, exhaust pipe

\* Cover the air cleaner (see under the heading 'Every 50 hours of operation' or 'Every 1000 hours of operation') or its opening with plastic or tape. Also cover the exhaust pipe opening. This is to avoid moisture entering the engine.

### Fuel tank

Fill the fuel tank completely full to prevent condensation.

### Hydraulic reservoir

Fill the hydraulic reservoir to the uppermost level mark (see under the heading 'Every 10 hours of operation.')

### Tires

Check that the tire pressure is 200 kPa (2,0 kp/cm<sup>2</sup>).

### **Hoods, tarpaulin**

\* Lower the instrument cover over the instrument panel.

\* Cover the entire roller with a tarpaulin. A gap must be left between the tarpaulin and the ground.

\* If possible, store the roller indoors and ideally in a building where the temperature is constant.

### **Steering cylinder, hinges, etc.**

Grease the steering cylinder piston with conservation grease.

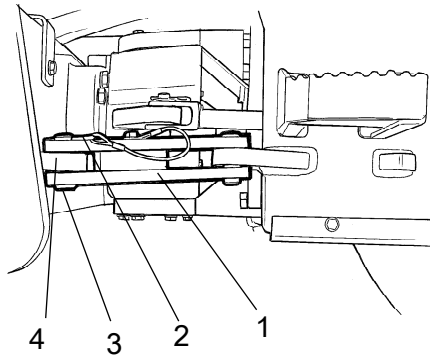
Grease the hinges on the doors to the engine compartment. Grease both ends of the forward/reverse control (bright parts) (see under the heading 'Every 500 hours of operation').

## Miscellaneous

### Lifting

#### Locking the articulation

 **Articulation must be locked to prevent inadvertent turning before lifting the roller.**



**Fig. Articulation in the locked position**

1. Locking arm
2. Locking pin
3. Locking stud
4. Locking lug

Weight: refer to the hoisting plate on the roller


Turn the steering wheel to the straight ahead position. Enable the parking brake (31).


Pull out the locking pin (2) fitted with a wire, and pull up the stud (3).

Fold out the locking arm (1) and place it over the locking lug (4) on the drum frame.

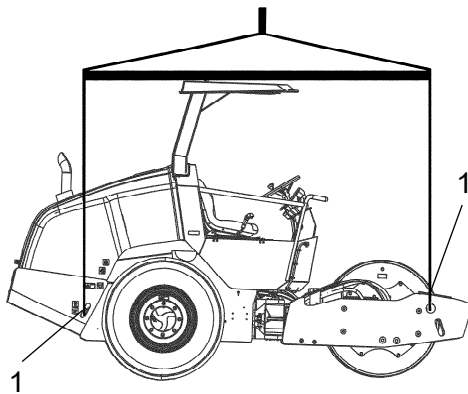
Fit the locking stub (3) in the holes through the locking arm (1) and locking lug (4) and secure the stud in position with the locking pin (2).

#### Lifting the roller

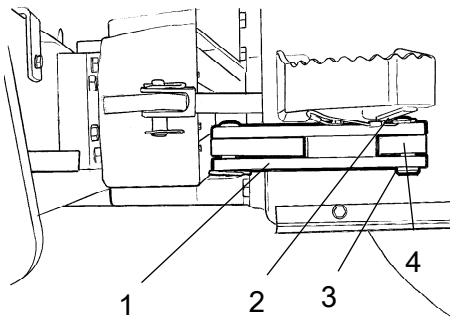
 **The machine's gross weight is specified on the hoisting plate (1). Refer also to the Technical specifications.**

 Lifting equipment such as chains, steel wires, straps and lifting hooks must be dimensioned in accordance with the relevant safety regulations for the lifting equipment.

 **Stand well clear of the hoisted machine! Make sure that the lifting hooks are properly secured.**



**Fig. Roller prepared for lifting**  
1. Hoisting plate



**Fig. Articulation in the open position**

- 1. Locking arm
- 2. Locking pin
- 3. Locking stud
- 4. Locking lug

### Unlocking the articulation



Remember to unlock the articulation before operating.

Fold the locking arm (3) back and secure it in the locking lug (4) with the stud (3). Insert the locking pin (2) fitted with a wire, to secure the stud (3). The locking lug (4) is located on the tractor frame.

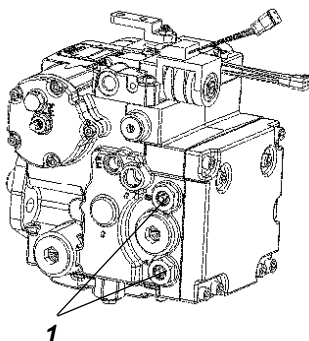
### Towing

The roller can be moved up to 300 meters (1,000 ft) using the instructions below.

#### Short distance towing with switched off engine



**Check the wheels to prevent the roller from moving when the brakes are hydraulically disengaged.**



**Fig. Propulsion pump**  
1. By-pass piston

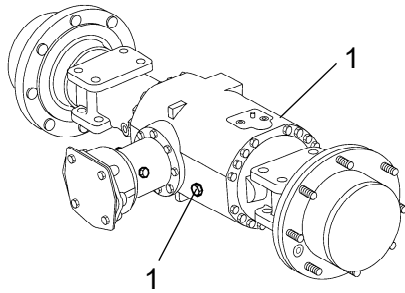
Open the hood and make sure that the propulsion pump is accessible.

On the pump there are two by-pass pistons (1), which should be pressed in to set the system in by-pass mode.

This function enables a machine to be moved without the drive shaft on the propulsion pump rotating.

The by-pass pistons (1) are automatically reset when the engine is started and the feed pressure builds up.

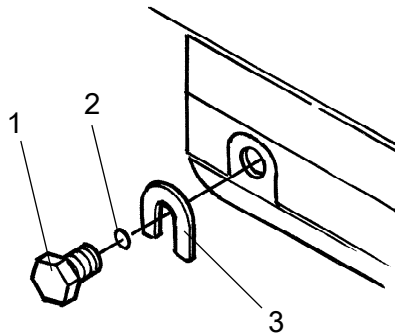




**Fig. Rear axle**  
1. Brake release screw (2).

### Rear axle brake

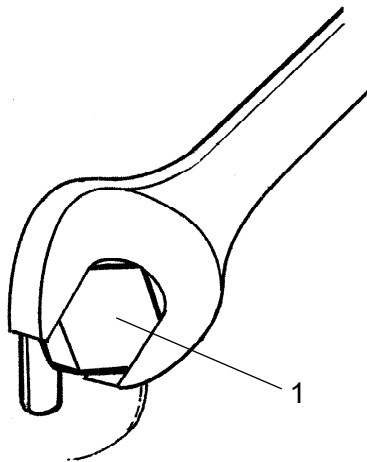
The two brake release screws (1) are located on the front and back of the rear axle.



**Fig. Brake disengagement**  
1. Brake release screw  
2. O-ring  
3. Stop washer

### Brake disengagement

Unscrew the brake release screws (1) and remove the stop washers (3). The screws must not be completely removed, only unscrewed enough to remove the washers.



**Fig. Brake disengagement**  
1. Brake release screw

Now tighten the brake release screws (1) alternately until they are fully screwed in.

The brake is now disengaged.

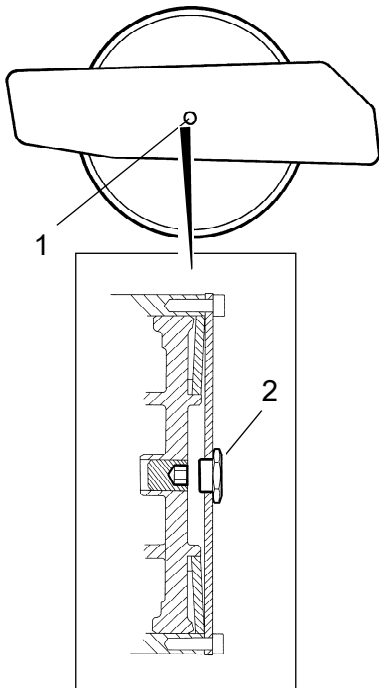


Reset the drum motor brake after towing.

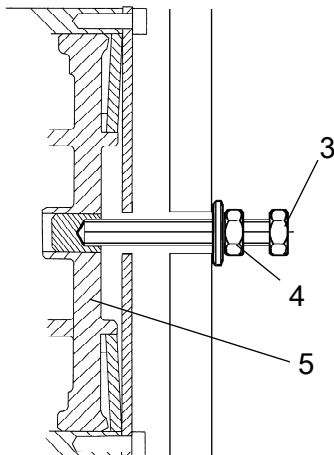
## Releasing the drum brake

### Drum motor brake

Remove the drum brake centre plug (2), which is accessible through the centre hole (1) in the left frame side.



**Fig. Left frame side**  
1. Center hole  
2. Center plug



**Fig. Cross-section of brake housing**  
3. Bolt  
4. Nut  
5. Brake piston


Screw in the bolt (3) all the way as shown in the figure. Now screw in the nut (4) so that it is flush with the washer, and then an additional 0,75 - 1 turns, holding the screw in place (3).

The brakes are now released and the machine can be towed.



Reset the drum motor brake after towing.

### Towing the roller

 **When towing/recovering, the roller must be braked by the towing vehicle. A towing bar must be used as the roller has no brakes.**

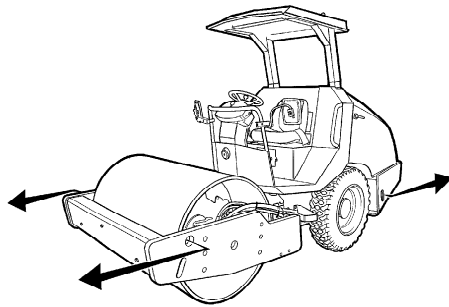




Fig. Towing

 The roller must be towed slowly, max. 3 kp/h (2 mph) and only towed short distances, max. 300 m (330 yards).

When towing/retrieving a machine, the towing device must be connected to both lifting holes. The pulling force must act longitudinally on the machine as illustrated. Maximum gross pulling force 70 kN (15740 lbf).

 Reset the towing procedures described on the previous pages.

### Transport

Tie-down and secure the machine according to the Cargo Securing Certificate for the specific machine if this is available and applicable.

If not, tie down and secure the machine according to the cargo securing rules that are valid for the country where the transport takes place.

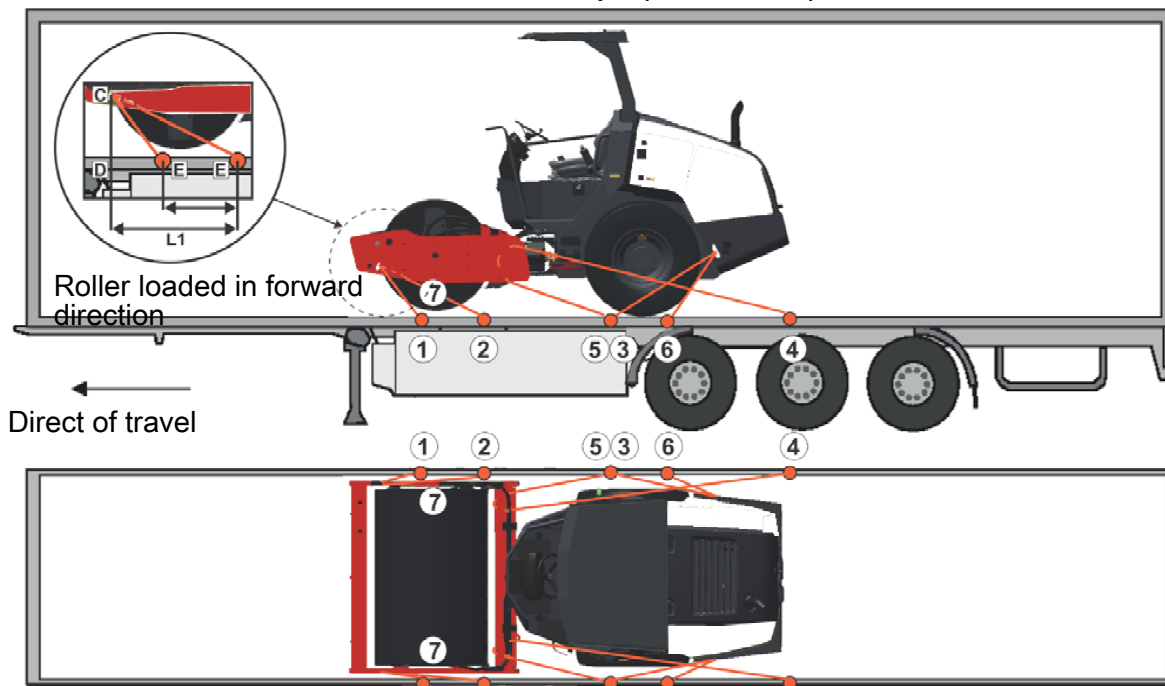
 **Never lash over the machine's articulated joint, nor over the machine's operator platform.**

Before securing the machine ensure that :

- the parking brake is applied and in good working condition
- the articulated joint is in closed position
- the machine is centered laterally on the platform
- the lashings are in good condition and fulfills the corresponding rules for transport securing.

### Securing CA1300 for loading

Securing the CA1300D/PD vibratory roller from Dynapac for transport.



- 1 - 2 = double lashings, i.e. one lashing with two parts secured to two different lashing mounts,
- 3 - 4 symmetrically located on the right and left sides.
- 5 - 6
- 7 = rubber

The lashings' permitted distance interval in meters		
(1 - 6: Double lashings, LC at least 1.7 tonnes (1700 daN), S <sub>TF</sub> 300 kg (300daN))		
Double L <sub>1</sub> - L <sub>2</sub>	Double L <sub>3</sub> - L <sub>4</sub>	Double L <sub>5</sub> - L <sub>6</sub>
1,2 - 3,0	1,1 - 3,0	0,3 - 3,0

The distance  $L_1$  above is between points **D** and **E**. **D** is the projected point directly at right angles laterally in relation to the edge of the platform from the lashing mount **C** on the roller. **E** is the lashing mount at the edge of the platform.  $L_2 - L_3$  have a corresponding relationship.

**Load carrier**

- When loaded, the vibratory roller is centered laterally on the platform ( $\pm 5$  cm).
- The parking brake is applied and in good working condition, and the articulated joint lock is closed.
- The drum is placed on a rubber liner, so that the static friction between the surfaces is at least 0.6.
- The contact surfaces must be clean, wet or dry, and free from frost, ice and snow.
- The lashing mounts on the load carrier have LC/MSL at least 2 tonnes.

**Lashings**

- The lashings comprise a lashing strap or chain with a permitted load (LC/MSL) of at least 1.7 tonnes (1,700 daN) and a pre-tension  $S_{TF}$  of at least 300 kg (300 daN). The lashings are re-tightened as required.
- Each of lashings 1-3 is either a double or two single lashings. A double lashing runs in a sling through a lashing point or around a machine part and down into two different mounts on the platform.
- Lashings in the same direction are placed in different lashing mounts on the trailer. Lashings that are pulled in opposite directions may be placed in the same lashing mount, however.
- The lashings are as short as possible.
- The lashing hooks must not lose grip if the lashings become slack.
- The lashings are protected against sharp edges and corners.
- The lashings are located symmetrically in pairs on the right and left sides.



### Operating instructions - Summary



1. **Follow the SAFETY INSTRUCTIONS specified in the Safety Manual.**
2. Make sure that all instructions in the MAINTENANCE section are followed.
3. Turn the master switch to the ON position.
4. Move the forward/reverse lever to the NEUTRAL position.
5. Set the vibration switch in position 0.
6. Set the engine speed control to idle (800 rpm).
7. Set the emergency stop in the pulled out position.
8. Start the engine and allow it to warm up.
9. Set the engine speed control to the operating position (2200 rpm).



10. **Drive the roller. Operate the forward/reverse lever with care.**



11. **Test the brakes. Remember that the braking distance will be longer if the roller is cold.**

12. Use vibration only when the roller is in motion.



13. **IN AN EMERGENCY:**
  - Press the emergency stop
  - Hold the steering wheel firmly.
  - Brace yourself for a sudden stop.
14. When parking:
  - Press the emergency stop.
  - Chock the drum and wheels.
15. When lifting: - Refer to the relevant section in the Instruction Manual.
16. When towing: - Refer to the relevant section in the Instruction Manual.
17. When transporting: - Refer to the relevant section in the Instruction Manual.
18. When recovering - Refer to the relevant section in the Instruction Manual.





### Preventive maintenance

Complete maintenance is necessary for the machine to function satisfactorily and at the lowest possible cost.

The Maintenance section includes the periodic maintenance that must be carried out on the machine.

The recommended maintenance intervals assume that the machine is used in a normal environment and working conditions.

### Acceptance and delivery inspection

The machine is tested and adjusted before it leaves the factory.

On arrival, before delivery to the customer, delivery inspection must be conducted as per the check list in the warranty document.

Any transport damage must be reported immediately to the transport company, as this is not covered by the product warranty.

### Warranty

The warranty is only valid if the stipulated delivery inspection and the separate service inspection have been completed as per the warranty document, and when the machine has been registered for starting under the warranty.

The warranty is not valid if damage has been caused by inadequate service, incorrect use of the machine, the use of lubricants and hydraulic fluids other than those specified in the manual, or if any other adjustments have been made without the requisite authorisation.



### Maintenance - Lubricants and symbols

#### Fluid volumes

Rear axle		
- Differential	4,5 liters	4,2 qts
- Planetary gear	0,9 liters/side	0,95 qts/side
- Pinion housing	0,3 liters	0,32 qts
Drum	6.5 liters	6.8 qts
Hydraulic reservoir	32,0 liters	8,4 gal
Oil in hydraulic system	42.0 liters	11.1 gal
Lubrication oil, diesel engine	11.2 liters	11.8 qts
Coolant, diesel engine	10.0 liters	10.5 qts
















Always use high-quality lubricants and the amounts recommended. Too much grease or oil can cause overheating, resulting in rapid wear.

	ENGINE OIL	Air temperature -15°C - +50°C (5°F-122°F)	<b>Dynapac Engine Oil 200</b>	P/N 4812161855 (5 liters) P/N 4812161856 (20 liters)
	HYDRAULIC FLUID	Air temperature -15°C - +50°C (5°F-104°F)	<b>Dynapac Hydraulic 300</b>	P/N 4812161868 (20 liters) P/N 4812161869 (209 liters)
		Air temperature over +50°C (104°F)	Shell Tellus S2 V100	
	BIOLOGICAL HYDRAULIC FLUID, PANOLIN	When it leaves the factory, the machine may be filled with biologically degradable fluid. The same type of fluid must be used when changing or topping up.	PANOLIN HLP Synth 46 (www.panolin.com)	
	BIOLOGICAL HYDRAULIC FLUID	When it leaves the factory, the machine may be filled with biologically degradable fluid. The same type of fluid must be used when changing or topping up.	BP Biohyd SE-S46	
	DRUM OIL	Air temp. -15°C - +40°C (5°F-104°F)	<b>Dynapac Gear oil 300</b>	P/N 4812161883 (5 liters), P/N 4812161884 (20 liters)
		Air temp. 0°C (32°F) - above +40°C (104°F)	Shell Spirax AX 85W/140, API GL-5	
	GREASE		for the articulated joint.	<b>Dynapac Roller Grease</b> (0.4 kg), P/N 4812030096
			Shell Retinax LX2 for other grease points.	
	FUEL	See engine manual.	-	-
	TRANSMISSION OIL	Air temperature -15°C - +40°C (5°F-104°F)	<b>Dynapac Gear oil 300</b>	P/N 4812161883 (5 liters), P/N 4812161884 (20 liters)
		Air temperature 0°C (32°F) - above +40°C (104°F)	Shell Spirax AX 85W/140, API GL-5	
	COOLANT	Anti-freeze protection down to about -37°C (-34.6°F)	<b>Dynapac Coolant 100</b> (mixed 50/50 with water)	P/N 4812161854 (20 liters)



Other fuel and lubricants are required when operating in areas with extremely high or extremely low ambient temperatures. See the 'Special instructions' chapter, or consult Dynapac.

### Maintenance symbols

	Engine, oil level		Tyre pressure
	Engine, oil filter		Air filter
	Hydraulic reservoir, level		Battery
	Hydraulic fluid, filter		Recycling
	Transmission, oil level		Fuel filter
	Drum, oil level		Coolant, level
	Oil for lubrication		



Maintenance - Maintenance schedule

Service and maintenance points

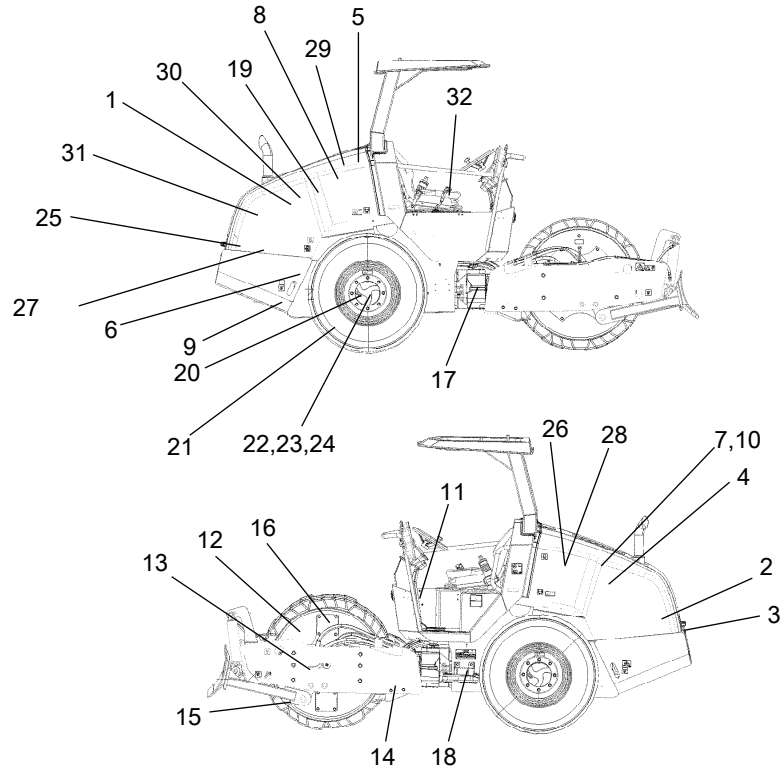


Fig. Service and maintenance points

- |  |  |                               |
|--|--|-------------------------------|
| 1. Radiator grille                     | 14. Scraper                                    | 27. Engine suspension, 4 pcs. |
| 2. Oil level, diesel engine            | 15. Drum oil, level plug, 1 pc.                | 28. Diesel fuel, filler       |
| 3. Fuel filter                         | 16. Rubber elements and fastening screws       | 29. Battery                   |
| 4. Air filter                          | 17. Steering joint                             | 30. Radiator                  |
| 5. Engine cover, hinges                | 18. Steering cylinder, 1 pc.                   | 31. Drive belt, alternator    |
| 6. Hydraulic reservoir, sight glass    | 19. Flywheel casing, hydraulic pumps           | 32. Forward/reverse lever     |
| 7. Bleeding filter                     | 20. Wheel nuts                                 |                               |
| 8. Hydraulic filter, 1 pcs.            | 21. Tires, pressure                            |                               |
| 9. Drainage, hydraulic fluid reservoir | 22. Rear axle, differential and pinion housing |                               |
| 10. Hydraulic fluid, filling           | 23. Rear axle, planetary gears, 2 pcs.         |                               |
| 11. Fuse box                           | 24. Rear axle suspension, 2 sides              |                               |
| 12. Drum oil, filling                  | 25. Oil filter, diesel engine                  |                               |
| 13. Drum motor                         | 26. Cleaning, fuel tank                        |                               |

### General

Periodic maintenance should be carried out after the number of hours specified. Use the daily, weekly etc. periods where number of hours cannot be used.



Remove all dirt before filling, when checking oils and fuel and when lubricating using oil or grease.



The manufacturer's instructions found in the engine manual also apply.

Specific maintenance and checks on diesel engines must be carried out by the engine supplier's certified personnel.

### Every 10 hours of operation (Daily)

Refer to the contents to find the page number of the sections referred to !

Pos. in fig	Action	Comment
	<b>Before starting up for the first time on that day</b>	
1	Check for free circulation of cooling air	
30	Check coolant level	
2	Check the engine oil level	Refer to the engine manual
28	Refuel	
6	Check fluid level in hydraulic reservoir	
	Test the brakes	
	Check the drive belt	Refer to the Instruction manual for the engine

### After the FIRST 50 hours of operation

Refer to the contents to find the page number of the sections referred to !

Pos. in fig	Action	Comment
2	Change the engine oil and oil filter	Refer to the engine manual
3	Change the fuel filter	Refer to the engine manual
8	Change the hydraulic fluid filter	



### Every 50 hours of operation (Weekly)

Refer to the contents to find the page number of the sections referred to!

Pos. in fig	Action	Comment
14	Check the scraper setting	
20	Check the wheel-nuts are tightened	
21	Check the tire pressure	
4	Check the air cleaner	Replace as required
	Check that hoses and couplings are not leaking	
3	Draining the fuel prefilter	Performed if the control lamp for the water separator lights on the instrument panel.

### Every 250 / 750 / 1250 / 1750 hours of operation

Refer to the contents to find the page number of the sections referred to !

Pos. in fig	Action	Comment
23	Check oil level in rear axle/planetary gearing	
22	Check the oil level in the rear axle pinion housing	
15	Check the oil level in the drum	
30	Clean coolers	
	Adjust the engine drive belt	Refer to the engine manual
	Check the air intake hoses	
16	Check rubber elements and bolted joints	
29	Check battery	

### Every 500 hours of operation

Refer to the contents to find the page number of the sections referred to !

Pos. in fig	Action	Comment
23	Check oil level in rear axle/planetary gearing	
22	Check oil level in the rear axle pinion housing	
15	Check oil level in the drum	
30	Clean coolers	
16	Check rubber elements and bolted joints	
29	Check battery	
3	Replace fuel filter	Refer to the engine manual
25	Change the engine oil and oil filter	Refer to the engine manual
31	Adjust the belt tension for the drive system	Refer to the engine manual
	Replace the belt for the drive system	Refer to the engine manual
32	Lubricate controls and joints	
7	Check air cleaner on hydraulic reservoir	

### Every 1000 hours of operation

Refer to the contents to find the page number of the sections referred to !

Pos. in fig	Action	Comment
15	Check oil level in the drum	
30	Check coolers	
	Change drive belt	Refer to the engine manual
	Valve adjustment, engine	Refer to the engine manual
16	Check rubber elements and bolted joints	
29	Check battery	
3	Replace fuel filter	Se även motorns instruktionsbok
32	Lubricate controls and joints	
25	Change the engine oil and oil filter	Se även motorns instruktionsbok
7	Check air cleaner on hydraulic reservoir	
31	Check the belt tension for the drive system	Refer to the engine manual
8	Change hydraulic fluid filter	
9	Drain the condensate from hydraulic reservoir	
26	Drain condensate from fuel tank	
22	Change oil in rear axle differential	
22	Change the oil in the rear axle pinion housing	
23	Change oil in the rear axle planetary gearing	

## Maintenance - Maintenance schedule

### Every 1500 hours of operation

Refer to the contents to find the page number of the sections referred to !

Pos. in fig	Action	Comment
23	Check oil level in rear axle/planetary gearing	
22	Check oil level in the rear axle pinion housing	
15	Check the oil level in the drum	
30	Clean coolers	
	Cleaning the water separator	
16	Check rubber elements and bolted joints	
29	Check battery	
3	Replace fuel filter	Also refer to the engine manual
32	Lubricate controls and joints	
25	Change the engine oil and oil filter	Also refer to the engine manual
7	Check air cleaner on hydraulic reservoir	
31	Adjust the belt tension for the drive system	Refer to the engine manual
31	Replace the belt for the drive system	Refer to the engine manual
33	Change oil separator element	Also refer to the engine manual

### Every 2000 hours of operation

Refer to the contents to find the page number of the sections referred to !

Pos. in fig	Action	Comment
30	Clean coolers	
20, 24	Check bolted joints	The above applies to new or reconditioned components only
16	Check rubber elements and bolted joints	
29	Check battery	
3	Replace fuel filter	Refer to the engine manual
32	Lubricate controls and joints	
25	Change the engine oil and oil filter	Refer to the engine manual
7	Check air cleaner on hydraulic reservoir	
31	Check the belt tension for the drive system	Refer to the engine manual
	Change the belt for the drive system	Refer to the engine manual
8	Change hydraulic oil filter	
9	Drain the condensate from hydraulic reservoir	
26	Drain the condensate from fuel tank	
22	Change oil in rear axle differential	
22	Change oil in the rear axle pinion housing	
23	Change oil in the rear axle planetary gearing	
9	Change the hydraulic fluid	
12	Change the oil in the drum	
17	Check the steering joint	

## Service - Checklist

Pos	Action	Frequency										NOTE					
		After the first 10 hours of operation (Daily)	Every 50 hours of operation (Weekly)	Every 250 hours of operation	Every 500 hours of operation	Every 750 hours of operation	Every 1000 hours of operation	Every 1250 hours of operation	Every 1500 hours of operation	Every 1750 hours of operation	Every 2000 hours of operation		Every 24 months				
1	Check for free circulation of cooling air	<input type="checkbox"/>															
30	Check/Change coolant level	<input type="checkbox"/>															Refer to the engine manual
2	Check the engine oil level	<input type="checkbox"/>															Refer to the engine manual
28	Refuel	<input type="checkbox"/>															
6/9	Check/Change fluid level in hydraulic reservoir	<input type="checkbox"/>															
	Test the brakes	<input type="checkbox"/>															
2/25	Change the engine oil and oil filter	<input checked="" type="checkbox"/>															Refer to the engine manual
3	Replace the fuel filter	<input checked="" type="checkbox"/>															Refer to the engine manual
8	Change the hydraulic fluid filter	<input checked="" type="checkbox"/>															
	Check that hoses and couplings are not leaking	<input type="checkbox"/>															
14	Check the scraper setting	<input type="checkbox"/>															
4	Inspect/clean the filter element in the air cleaner	<input type="checkbox"/>															
20	Check the wheel-nuts are tightened	<input type="checkbox"/>															
21	Check the tire pressure	<input type="checkbox"/>															
23/22	Check the oil level /Change the oil in rear axle/plane:ary gears	<input type="checkbox"/>	<input type="checkbox"/>	<input type="checkbox"/>	<input type="checkbox"/>	<input type="checkbox"/>	<input type="checkbox"/>	<input type="checkbox"/>	<input type="checkbox"/>	<input type="checkbox"/>	<input type="checkbox"/>	<input type="checkbox"/>	<input type="checkbox"/>	<input type="checkbox"/>	<input type="checkbox"/>		Replace as required
22	Check the oil level/Change the oil in the rear axle pinion housing	<input type="checkbox"/>	<input type="checkbox"/>	<input type="checkbox"/>	<input type="checkbox"/>	<input type="checkbox"/>	<input type="checkbox"/>	<input type="checkbox"/>	<input type="checkbox"/>	<input type="checkbox"/>	<input type="checkbox"/>	<input type="checkbox"/>	<input type="checkbox"/>	<input type="checkbox"/>	<input type="checkbox"/>		
15/12	Check the oil level/Change the oil in the drum	<input type="checkbox"/>	<input type="checkbox"/>	<input type="checkbox"/>	<input type="checkbox"/>	<input type="checkbox"/>	<input type="checkbox"/>	<input type="checkbox"/>	<input type="checkbox"/>	<input type="checkbox"/>	<input type="checkbox"/>	<input type="checkbox"/>	<input type="checkbox"/>	<input type="checkbox"/>	<input type="checkbox"/>		
30	Clean the coolers	<input type="checkbox"/>															
	Adjust the engine drive belt	<input type="checkbox"/>															
	Check the air intake hoses	<input type="checkbox"/>															
16	Check rubber elements and bolted joints	<input type="checkbox"/>															
29	Check battery	<input type="checkbox"/>															
32	Lubricate controls and joints	<input type="checkbox"/>															
7	Check/Change bleeder filter on hydraulic reservoir	<input type="checkbox"/>															
31	Check/Change belt tension/drive belt - system	<input type="checkbox"/>															Refer to the engine manual
	Cleaning the water separator	<input type="checkbox"/>															
9	Drain the condensate from hydraulic reservoir	<input type="checkbox"/>															
26	Drain condensate from fuel tank	<input type="checkbox"/>															
22	Change oil in rear axle differential	<input type="checkbox"/>															
	Change drive belt	<input type="checkbox"/>															
	Valve adjustment, engine	<input type="checkbox"/>															
	Change oil separator element	<input type="checkbox"/>															
17	Check the steering joint	<input type="checkbox"/>															

Check     Change

## Maintenance, 10h

Every 10 hours of operation (Daily)



**Park the roller on a level surface.  
The engine must be switched off and the parking brake activated when checking or adjusting the roller, unless otherwise specified.**

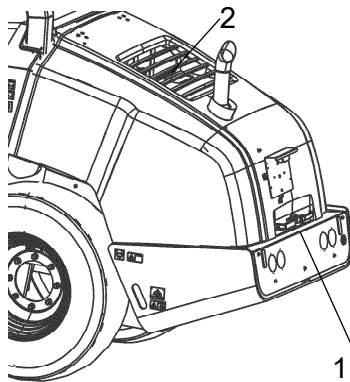
### Air circulation - Check

Ensure that the engine has free circulation of cooling air through the protective grille (2) in the hood.

To open the engine hood, turn the locking arm (1) upward. Raise the hood to its fully open position, checking that the red safety catch on the right gas spring is latched.



**If the gas-spring for the hood is disengaged and the hood is raised to its upper position - block the hood so that it cannot fall.**



**Fig. Engine hood**  
1. Hood lock  
2. Protective grille

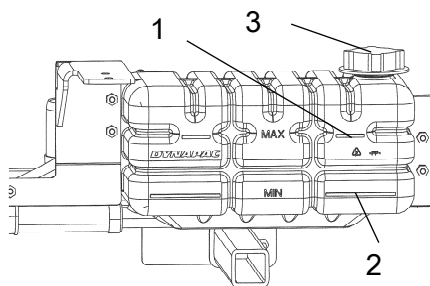


### Coolant level - Check

Check that level of the coolant is between the max. and min. marks.



**Take great caution if the radiator cap must be opened while the engine is hot. Wear protective gloves and goggles.**



**Fig. Water tank**  
1. Max. level  
2. Min. level  
3. Filler cap

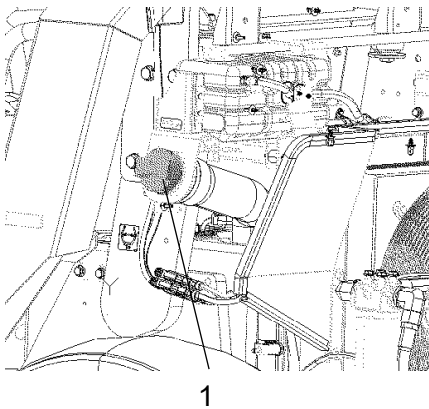
Fill with a mixture of 50% water and 50% anti freeze. See the lubrication specification in these instructions and in the engine manual.



**Flush the system every other year and change the coolant. Make sure also that the air flow through the cooler is unobstructed.**



## Fuel tank - Filling



**Fig. Filling with fuel**  
1. Filler pipe

Refuel daily with diesel fuel up to the lower edge of the filler pipe (1). Follow the engine manufacturer's specification with regard to the quality of diesel fuel.



**Stop the diesel engine. Short-circuit (press) the filler gun against a non-insulated part of the roller before filling, and against the filler pipe (1) while filling.**

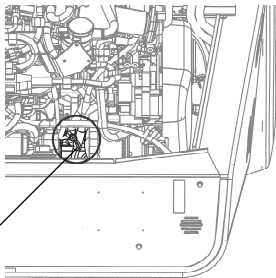


**Never refuel while the engine is running. Do not smoke and avoid spilling fuel.**

The tank holds 117 liters (31.7 gal) of fuel.



## Diesel engine Check oil level



**Fig. Engine compartment**  
1. Dipstick



**Take care not to touch any hot parts of the engine or the radiator when removing the dipstick. Risk for burns.**

The dipstick is located on the right side of the engine.

Pull up the dipstick (1) and check that the oil level is between the upper and lower marks. For further details, refer to the engine's instruction manual.



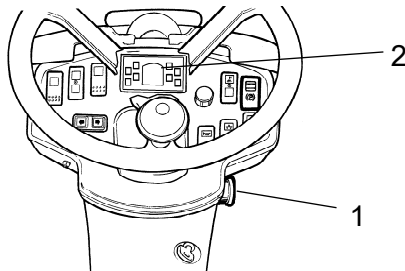
**Brakes - Check**



**Check operation of the brakes as follows:**



**Checking the emergency stop**



**Fig. Instrument panel**  
**1. Emergency stop**  
**2. Parking brake lamp**

Drive the roller slowly forward. Hold the steering wheel firmly and brace yourself for a sudden stop.

Press the emergency stop (1). The roller will stop abruptly and the engine will be switched off.

After testing the brakes, set the forward/reverse lever in neutral.

Pull out the emergency stop (1). Start the engine.

The roller is now ready for operation.

**Refer also to the section in the manual on operation.**

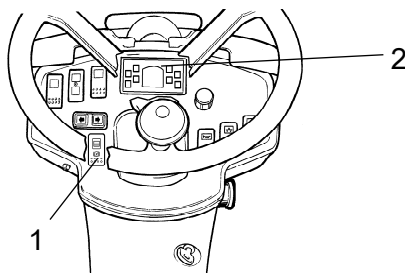
**Brakes - Check**



**Check operation of the brakes as follows:**



**Checking the parking brake**



**Fig. Instrument panel**  
**1. Parking brake**  
**2. Parking brake lamp**

Drive the roller slowly forward. Hold the steering wheel firmly and brace yourself for a sudden stop.

Enable the parking brake (1). The roller should stop immediately with the engine running.

After testing the brakes, set the forward/reverse lever in neutral.

Reset the parking brake (1).

The roller is now ready for operation.

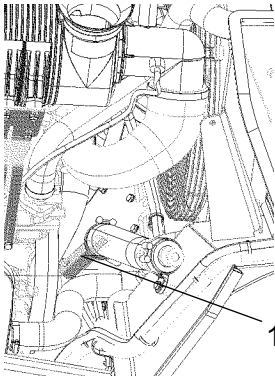
**Refer also to the section in the manual on operation.**



### Hydraulic reservoir - Check fluid level

The sight glass is located on the hydraulic tank in the engine compartment. It is accessible and visible from the right side of the roller.

Place the roller on a flat surface and check the fluid level in the sight glass. If the level is too low, top up with the type of hydraulic fluid specified in the lubricant specification.



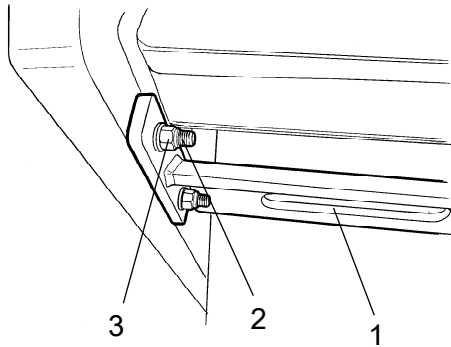
**Fig. Sight glass hydraulic reservoir**  
**1. Sight glass**

### Maintenance - 50h

Every 50 hours of operation (Weekly)



***Park the roller on a level surface.  
The engine must be switched off and the parking brake activated when checking or adjusting the roller, unless otherwise specified.***



**Fig. Scrapers**  
**1. Scraper**  
**2. Screws**  
**3. Nuts**

### Scrapers - Check, adjustment

If necessary, adjust the distance to the drum as follows: the scraper is mounted on the underside of the rear cross beam.

Loosen the four screws (2) on the outside of the drum frame, and the nuts on the inside of the (3) drum frame.

Adjust the scraper (1) to:  
For the D model 20 mm from the roller  
For the PD model to 25 mm between the scraper teeth and the roller.

Tighten the screw (2) and nuts (3).



### Tires - Air pressure - Wheel nuts - Tightening

Check the tire pressures using a pressure gauge.

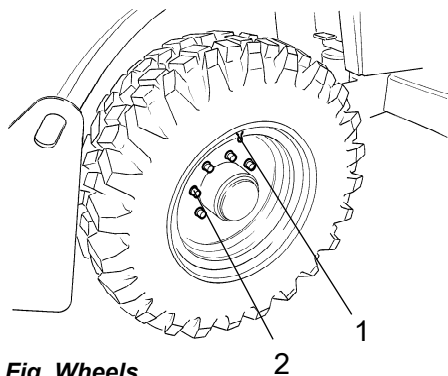
If the tires are filled with fluid, the air valve (1) must be in the "12 o'clock" position during pumping.

Recommended pressure: See Technical Specifications.

Check the tire pressure.



When changing the tires it is important that both of them have the same rolling radius. This is necessary to ensure proper functioning of the limited slip differential in the rear axle.



**Fig. Wheels**  
1. Air valve  
2. Wheel nut

Check the tightening torque on the wheel nuts (2) with 253 Nm (26 kpm).

Check both wheels and all nuts. (This only applies to a new machine or newly fitted wheels).



**Check the safety manual that accompanies the roller before filling the tires with air.**

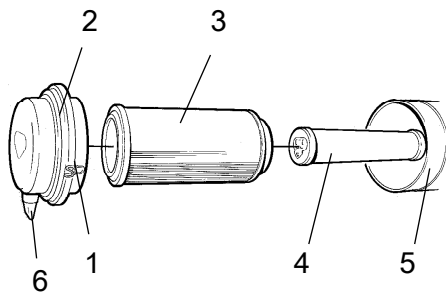


### Air cleaner

#### Check - Replacement of main filter



Replace the air cleaner's main filter when the indicator shows red. The indicator is mounted on the air cleaner's connecting pipe.



**Fig. Air cleaner**  
 1. Clips  
 2. Cover  
 3. Main filter  
 4. Backup filter  
 5. Filter housing  
 6. Dust valve

Release the clips (1), pull off the cover (2), and pull out the main filter (3).

Do not remove the backup filter (4).

Clean the air cleaner if necessary, see section Air cleaner - Cleaning.

When replacing the main filter (3), insert a new filter and refit the air cleaner in the reverse order.

Check the condition of the dust valve (6); replace if necessary.

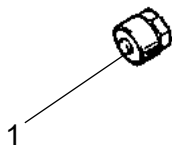
When refitting the cover, make sure that the dust valve is positioned downwards.

### Air filter indicator - Resetting

The air filter indicator is located on the filter, or in its immediate vicinity.

The air filter indicator must be reset after replacing the air filter.

Press the "button" (1) on the top of the indicator to reset.



**Fig. Indicator**  
 1. Button

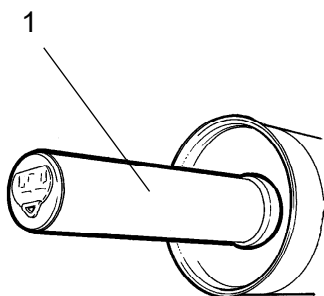


### Backup filter - Change

Change the backup filter with a new filter after every third replacement of the main filter.

To change the backup filter (1), pull the old filter out of its holder, insert a new filter and reassemble the air cleaner in the reverse order.

Clean the air cleaner if necessary, see section Air cleaner - Cleaning.



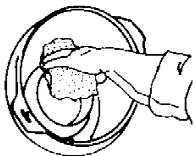
**Fig. Air filter**  
 1. Backup filter



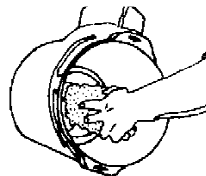
### Air cleaner - Cleaning

Wipe clean the inside of the cover (2) and the filter housing (5). See the previous illustration.

Wipe clean on both sides of the outlet pipe.



Inner edge of outlet pipe.



Outer edge of outlet pipe.

Wipe also both surfaces for the outlet pipe; see adjacent figure.



Check that the hose clamps between the filter housing and the suction hose are tight and that the hoses are intact. Inspect the entire hose system, all the way to the engine.



### Air cleaner - Check hoses and connections

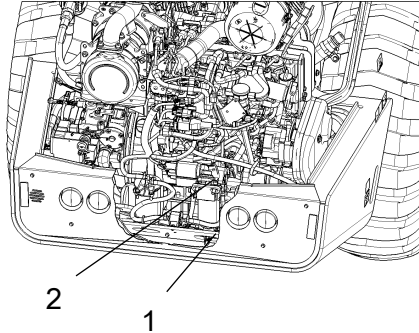


Check that the hose clamps between the filter housing and the suction hose are tight and that the hoses are intact. Inspect the entire hose system, all the way to the engine.

Replace if necessary, as damage to hoses/hose clamps can seriously damage the engine



### Pre-fuel filter - Draining



Unscrew the drain plug (1) at the bottom of the fuel prefilter.

With the aid of the secondary hand-operated pump, make certain that all sediment comes out.

Tighten the drain plug as soon as uncontaminated fuel runs out.

**Figure. Pre-fuel filter**  
**1. Drain plug**  
**2. Hand pump**





### Maintenance measures - 250 h

Every 250/750/1250/1750..... hours of operation (every 3 months)



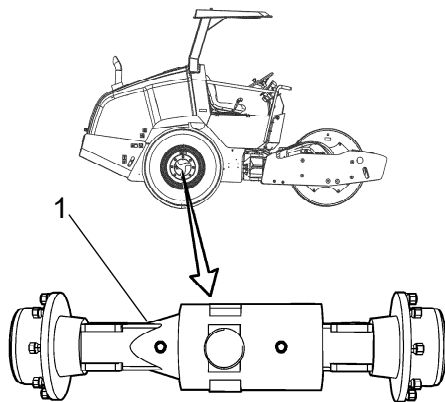
**Park the roller on a level surface. The engine must be switched off and the parking brake activated when checking or adjusting the roller, unless otherwise specified.**



#### Rear axle differential - Check oil level



**Never work under the roller when the engine is running. Park on a level surface. Block the wheels securely.**



**Fig. Level check - differential housing**  
1. Level/Filler plug

Wipe clean and remove the level plug (1) and check that the oil level reaches the lower edge of the plug hole. Top off with oil to the right level if the level is low. Use transmission oil according to the lubricant specification.

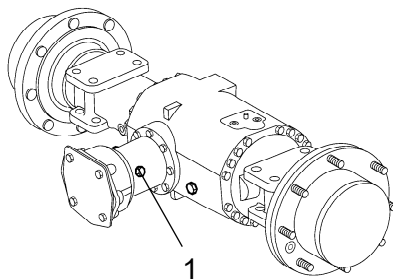
Clean and refit the plug.



#### Rear axle pinion housing - Checking the oil level



**Never work under the roller when the engine is running. Park on a level surface. Block the wheels securely.**



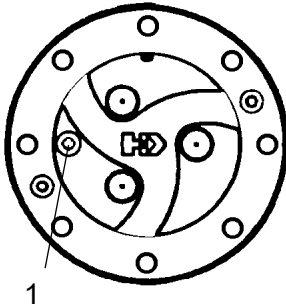
**Fig. Level check - Pinion housing**  
1. Level/Filler plug

Wipe clean and remove the level plug (1) and check that the oil level reaches the lower edge of the plug hole. Top off with oil to the right level if the level is low. Use transmission oil according to the lubricant specification.

Clean and refit the plug.



### Rear axle planetary gears - Check oil level



**Fig. Level check - planetary gear**  
1. Level/Filler plug

Position the roller with the plug in the planetary gear (1) in the "9 o'clock" position.

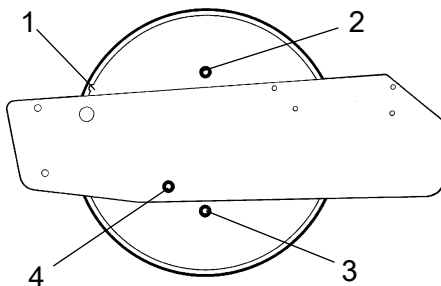
Wipe clean and remove the level plug (1) and check that the oil level reaches the lower edge of the plug hole. Top off with oil to the right level if the level is low. Use transmission oil according to the lubricant specification.

Clean and refit the plug.

Check the fluid level in the same way on the rear axle's other planetary gear.



### Drum - Checking the oil level



**Figure. Drum, left side**  
1. Groove  
2. Filler plug  
3. Drain plug/Magnetic plug  
4. Level plug

Position the roller on a flat surface with the groove (1) on the inside of the drum aligned with the top of the drum frame.

Release the level plug (4) and unscrew until oil starts to run out through the plug hole.

If necessary, release the filler plug (2) and fill with oil until it starts to run out through the level plug (4) hole.

Clean and screw in the level plug (4).

Clean and refit the filler plug (2).

See the lubrication specification for the correct oil grade.



Do not overfill with oil - risk for overheating.



### Coolers Checking - Cleaning

Make sure that the air flow through the coolers (1) and (2) is unobstructed. Dirty coolers are blown clean with compressed air or washed clean using a high-pressure water cleaner.

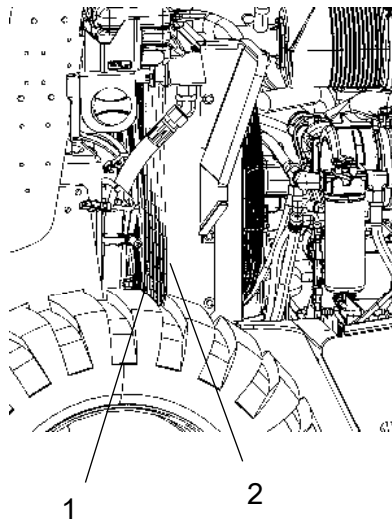
Blow air or direct water through the cooler in the opposite direction to that of the cooling air.



Take care when using a high-pressure water jet. Do not hold the nozzle too near the cooler.



***Wear protective goggles when working with compressed air or high-pressure water jets.***



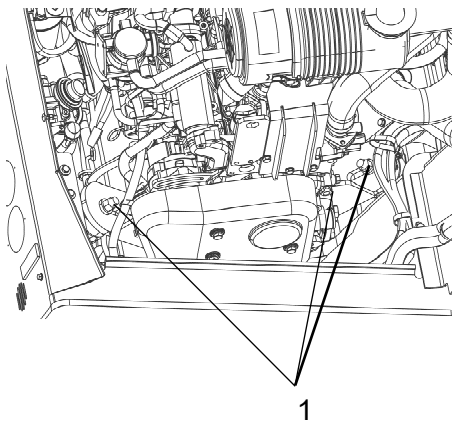
**Fig. Engine compartment**  
1. Water cooler  
2. Hydraulic fluid cooler

### Bolted joints - Checking tightening torque

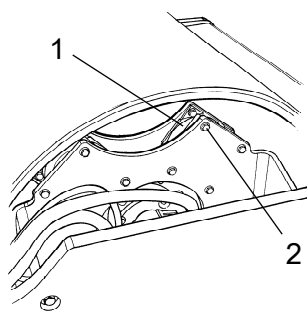
Check that all the bolts for the suspension of the engine and the drive unit are tightened, see under Specifications - tightening torque.

Check the bolted joint between the motor and the pump drive, and that all the hydraulic components are tightened to the set tightening torque.

(The above applies to new or replaced components only).



**Fig. Engine suspension**  
1. Bolted joint



**Fig. Drum, vibration side**  
1. Rubber element  
2. Screws

### Rubber elements and fastening screws - Check

Check all rubber elements (1), replace all of the elements if more than 25% of them on one side of the drum are cracked deeper than 10-15 mm (0.4-0.6 in).

Check using a knife blade or pointed object.

Check also that the screws (2) are tightened.



### Battery - Check condition

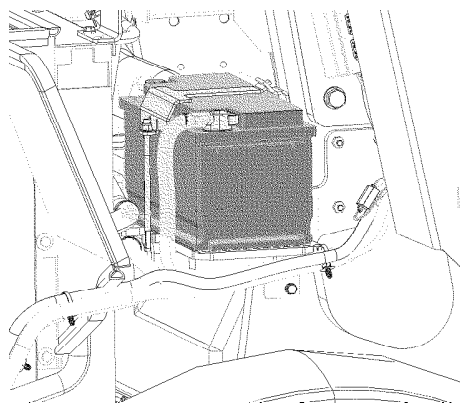
The batteries are sealed and maintenance-free.



***Make sure there is no open flame in the vicinity when checking the electrolyte level. Explosive gas is formed when the alternator charges the battery.***



**When disconnecting the battery, always disconnect the negative cable first. When connecting the battery, always connect the positive cable first.**




**Fig. Battery**


The cable shoes should be clean and tightened. Corroded cable shoes should be cleaned and greased with acid-proof Vaseline.

Wipe the top of the battery.


**Maintenance measures - 500 h**

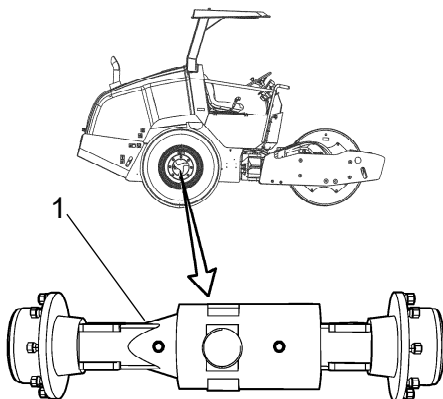
Every 500/1500..... hours of operation (every six months)

 **Park the roller on a level surface. The engine must be switched off and the parking brake activated when checking or adjusting the roller, unless otherwise specified.**

 **Ensure that there is good ventilation (air extraction) if the engine is run indoors. Risk of carbon monoxide poisoning.**

**Rear axle differential - Check oil level**

 **Never work under the roller when the engine is running. Park on a level surface. Block the wheels securely.**



**Fig. Level check - differential housing**  
**1. Level/Filler plug**

Wipe clean and remove the level plug (1) and check that the oil level reaches the lower edge of the plug hole. Top off with oil to the right level if the level is low. Use transmission oil according to the lubricant specification.

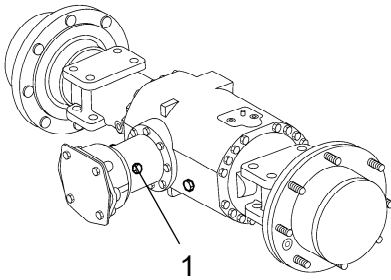
Clean and refit the plug.



### Rear axle pinion housing - Checking the oil level



**Never work under the roller when the engine is running. Park on a level surface. Block the wheels securely.**



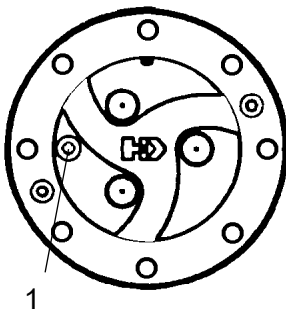
**Fig. Level check - Pinion housing**  
1. Level/Filler plug

Wipe clean and remove the level plug (1) and check that the oil level reaches the lower edge of the plug hole. Top off with oil to the right level if the level is low. Use transmission oil according to the lubricant specification.

Clean and refit the plug.



### Rear axle planetary gears - Check oil level



**Fig. Level check - planetary gear**  
1. Level/Filler plug

Position the roller with the plug in the planetary gear (1) in the "9 o'clock" position.

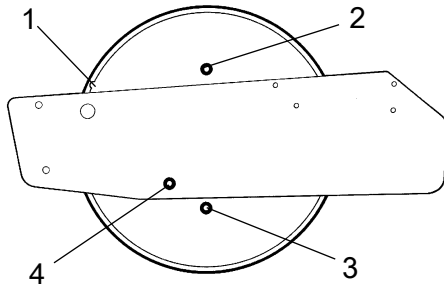
Wipe clean and remove the level plug (1) and check that the oil level reaches the lower edge of the plug hole. Top off with oil to the right level if the level is low. Use transmission oil according to the lubricant specification.

Clean and refit the plug.

Check the fluid level in the same way on the rear axle's other planetary gear.



### Drum - Checking the oil level



**Figure. Drum, left side**

- 1. Groove
- 2. Filler plug
- 3. Drain plug/Magnetic plug
- 4. Level plug

Position the roller on a flat surface with the groove (1) on the inside of the drum aligned with the top of the drum frame.

Release the level plug (4) and unscrew until oil starts to run out through the plug hole.

If necessary, release the filler plug (2) and fill with oil until it starts to run out through the level plug (4) hole.

Clean and screw in the level plug (4).

Clean and refit the filler plug (2).

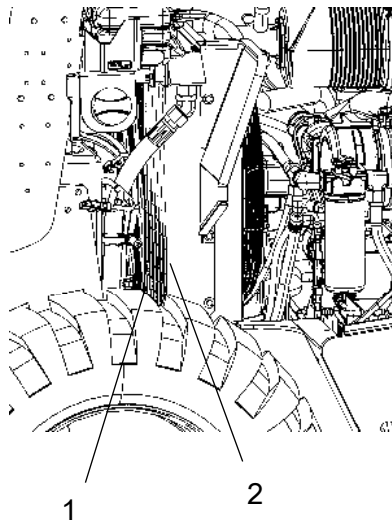
See the lubrication specification for the correct oil grade.



Do not overfill with oil - risk for overheating.



### Coolers Checking - Cleaning



**Fig. Engine compartment**

- 1. Water cooler
- 2. Hydraulic fluid cooler

Make sure that the air flow through the coolers (1) and (2) is unobstructed. Dirty coolers are blown clean with compressed air or washed clean using a high-pressure water cleaner.

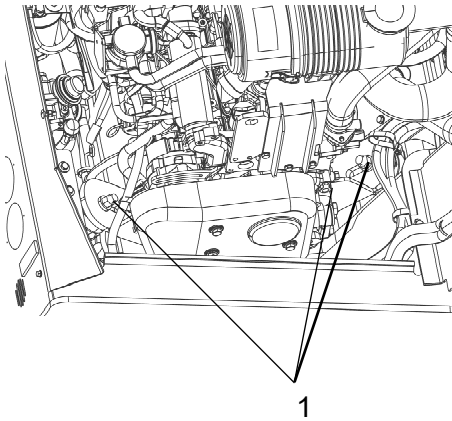
Blow air or direct water through the cooler in the opposite direction to that of the cooling air.



Take care when using a high-pressure water jet. Do not hold the nozzle too near the cooler.



**Wear protective goggles when working with compressed air or high-pressure water jets.**



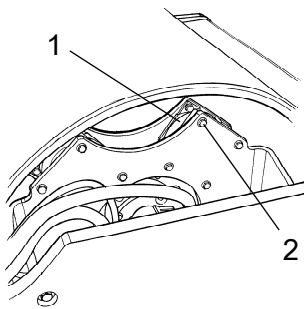
**Fig. Engine suspension**  
**1. Bolted joint**

### **Bolted joints - Checking tightening torque**

Check that all the bolts for the suspension of the engine and the drive unit are tightened, see under Specifications - tightening torque.

Check the bolted joint between the motor and the pump drive, and that all the hydraulic components are tightened to the set tightening torque.

(The above applies to new or replaced components only).



**Fig. Drum, vibration side**  
**1. Rubber element**  
**2. Screws**

### **Rubber elements and fastening screws - Check**

Check all rubber elements (1), replace all of the elements if more than 25% of them on one side of the drum are cracked deeper than 10-15 mm (0.4-0.6 in).

Check using a knife blade or pointed object.

Check also that the screws (2) are tightened.





### Battery - Check condition

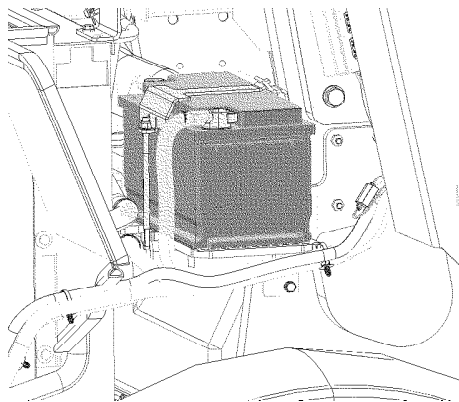
The batteries are sealed and maintenance-free.



**Make sure there is no open flame in the vicinity when checking the electrolyte level. Explosive gas is formed when the alternator charges the battery.**



When disconnecting the battery, always disconnect the negative cable first. When connecting the battery, always connect the positive cable first.



**Fig. Battery**

The cable shoes should be clean and tightened. Corroded cable shoes should be cleaned and greased with acid-proof Vaseline.

Wipe the top of the battery.

### The engine fuel filter - replacement/cleaning

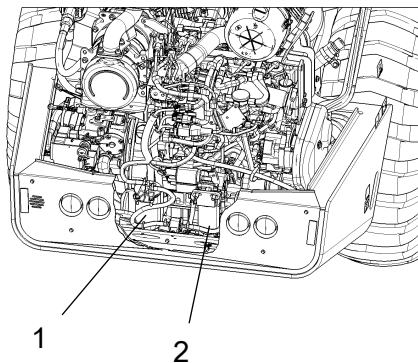


Place a container underneath to collect fuel that runs out when the filter is released.

Screw off the fuel filter (1). The filter is of the disposable type and cannot be cleaned. Hand in to environment-friendly station.



Refer to the engine manual for detailed instructions when replacing the fuel filter.



**Fig. Engine compartment**

1. Fuel filter
2. Fuel prefilter

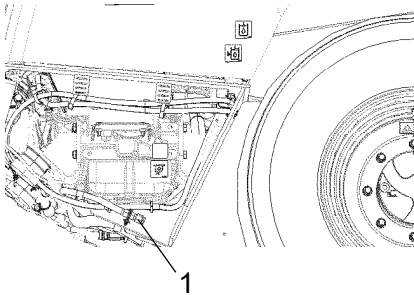
Unscrew the lower part of the fuel prefilter (2) and drain off any water, and then replace the filter unit.

Start the engine and check that the fuel filters are tight.

**N.B.** Under no circumstances may new fuel filters be pre-filled with fuel before assembly due to the demands on the cleanliness of the fuel system. Use the hand pump on the fuel prefilter to fill from the machine's fuel system.

**Diesel engine - Oil- and Filter change**

**Take great care when draining warm fluid and oil.  
Wear protective gloves and goggles.**



**Fig. Right side of engine  
1. Drain plug**

The oil plug (1) is most easily accessible from the underside of the engine, and is fitted with a hose on the tractor frame.

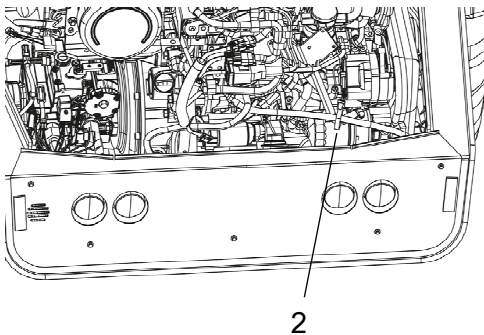
Place a receptacle that holds 15 liters (4 gal) under the drain plug.

Release the hose from its attachment and pull it forward to the tie-down hole.

Loosen the drain plug (1) and drain the oil, when the engine is warm.

Screw back the plug again and refit the hose in its attachment.

Change the engine oil filter (2) at the same time. Refer also to the Instruction Manual for the engine.



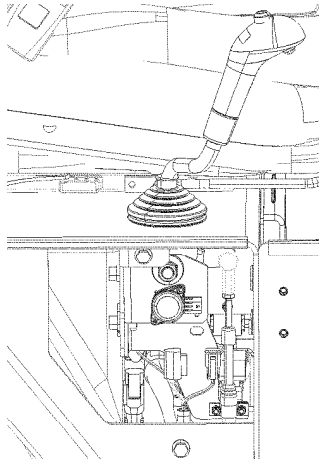
**Fig. Engine compartment  
2. Oil filter**



**Hand in the drained oil and filter to an  
environment-friendly waste disposal station.**



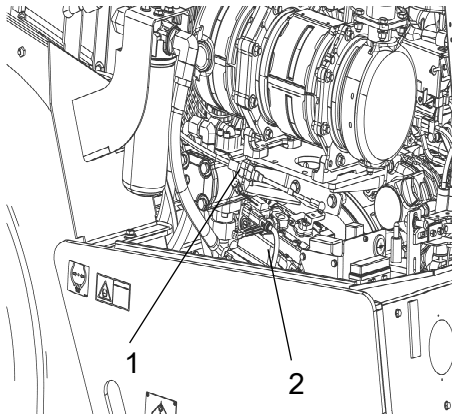
### Forward/Reverse controls and joints - Check and lubrication



**Fig. Forward/reverse lever**

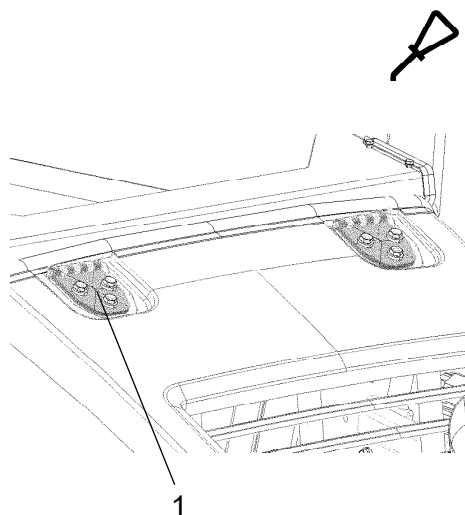
The forward/reverse lever joints are best accessed via the compartment for the manual on the right side of the operator station. Check the friction on the forward/reverse lever. The friction screws should be applied sufficiently hard that the forward/reverse lever remains in the set position during operation. The lever's 0-position is determined by the screw that grips in the groove on the axle between the lever.

If the lever begins to become stiff after prolonged used, lubricate the lever at the control cable with a few drops of oil at each point.



**Fig. Engine compartment**  
1. Forward/Reverse-control cable  
2. Propulsion pump

If the forward/reverse lever still is stiff after the above adjustments, lubricate the other end of the control cable with a few drops of oil. The cable is located on the top of the propulsion pump.



### Controls and moving joints - Lubrication

Lubricate the engine hood hinges (1) with grease, the other joints and controls are lubricated with oil. See lubricant specification.

**Fig. Engine hood**  
**1. Hinge**

**Maintenance - 1000h**

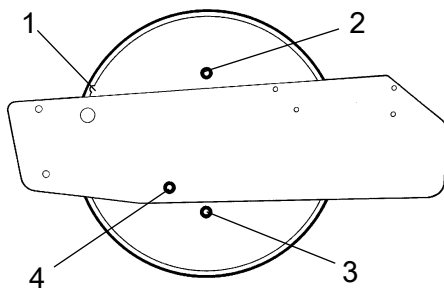
Performed after 1000 operating hours (each year)



**Park the roller on a level surface.  
The engine must be switched off and the parking brake activated when checking or adjusting the roller, unless otherwise specified.**



**Ensure that there is good ventilation (air extraction) if the engine is run indoors. Risk of carbon monoxide poisoning.**

**Drum - Checking the oil level**

**Figure. Drum, left side**

- 1. Groove**
- 2. Filler plug**
- 3. Drain plug/Magnetic plug**
- 4. Level plug**

Position the roller on a flat surface with the groove (1) on the inside of the drum aligned with the top of the drum frame.

Release the level plug (4) and unscrew until oil starts to run out through the plug hole.

If necessary, release the filler plug (2) and fill with oil until it starts to run out through the level plug (4) hole.

Clean and screw in the level plug (4).

Clean and refit the filler plug (2).

See the lubrication specification for the correct oil grade.



**Do not overfill with oil - risk for overheating.**



## Coolers

### Checking - Cleaning

Make sure that the air flow through the coolers (1) and (2) is unobstructed. Dirty coolers are blown clean with compressed air or washed clean using a high-pressure water cleaner.

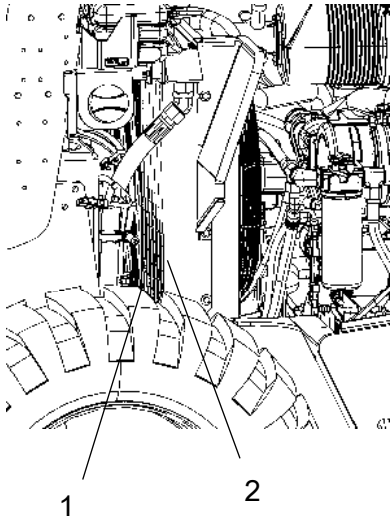
Blow air or direct water through the cooler in the opposite direction to that of the cooling air.



Take care when using a high-pressure water jet. Do not hold the nozzle too near the cooler.



***Wear protective goggles when working with compressed air or high-pressure water jets.***



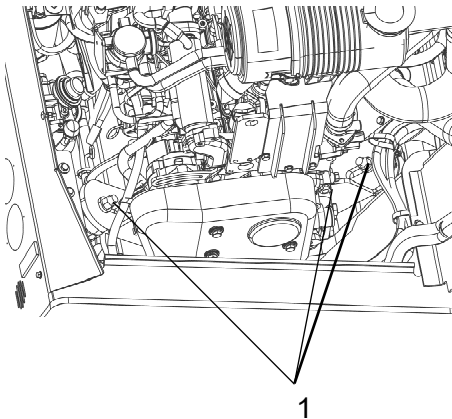
**Fig. Engine compartment**  
1. Water cooler  
2. Hydraulic fluid cooler

## Bolted joints - Checking tightening torque

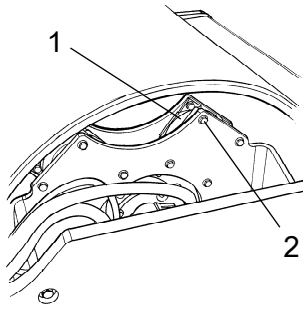
Check that all the bolts for the suspension of the engine and the drive unit are tightened, see under Specifications - tightening torque.

Check the bolted joint between the motor and the pump drive, and that all the hydraulic components are tightened to the set tightening torque.

(The above applies to new or replaced components only).



**Fig. Engine suspension**  
1. Bolted joint



**Fig. Drum, vibration side**  
1. Rubber element  
2. Screws

### Rubber elements and fastening screws - Check

Check all rubber elements (1), replace all of the elements if more than 25% of them on one side of the drum are cracked deeper than 10-15 mm (0.4-0.6 in).

Check using a knife blade or pointed object.

Check also that the screws (2) are tightened.



### Battery - Check condition

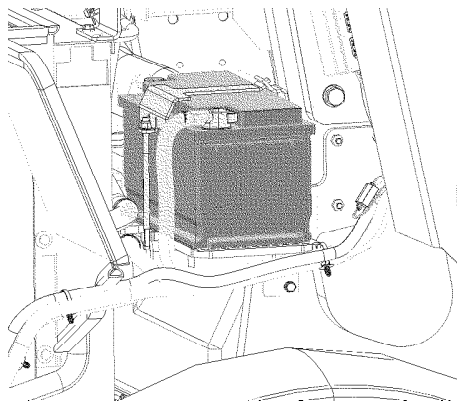
The batteries are sealed and maintenance-free.



***Make sure there is no open flame in the vicinity when checking the electrolyte level. Explosive gas is formed when the alternator charges the battery.***



**When disconnecting the battery, always disconnect the negative cable first. When connecting the battery, always connect the positive cable first.**



**Fig. Battery**

The cable shoes should be clean and tightened. Corroded cable shoes should be cleaned and greased with acid-proof Vaseline.

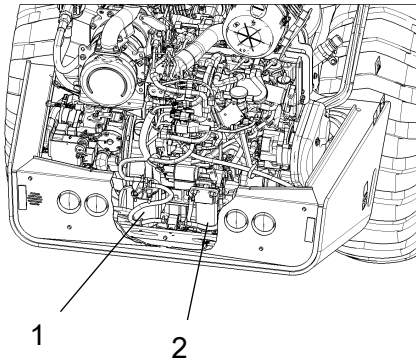
Wipe the top of the battery.



### The engine fuel filter - replacement/cleaning



Place a container underneath to collect fuel that runs out when the filter is released.



**Fig. Engine compartment**  
**1. Fuel filter**  
**2. Fuel prefilter**



Refer to the engine manual for detailed instructions when replacing the fuel filter.

Unscrew the lower part of the fuel prefilter (2) and drain off any water, and then replace the filter unit.

Start the engine and check that the fuel filters are tight.

**N.B.** Under no circumstances may new fuel filters be pre-filled with fuel before assembly due to the demands on the cleanliness of the fuel system. Use the hand pump on the fuel prefilter to fill from the machine's fuel system.

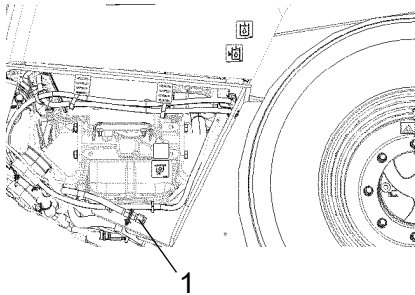




## Diesel engine - Oil- and Filter change



**Take great care when draining warm fluid and oil.  
Wear protective gloves and goggles.**



**Fig. Right side of engine  
1. Drain plug**

The oil plug (1) is most easily accessible from the underside of the engine, and is fitted with a hose on the tractor frame.

Place a receptacle that holds 15 liters (4 gal) under the drain plug.

Release the hose from its attachment and pull it forward to the tie-down hole.

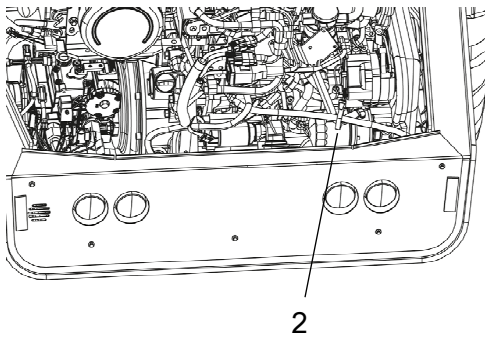
Loosen the drain plug (1) and drain the oil, when the engine is warm.

Screw back the plug again and refit the hose in its attachment.

Change the engine oil filter (2) at the same time. Refer also to the Instruction Manual for the engine.



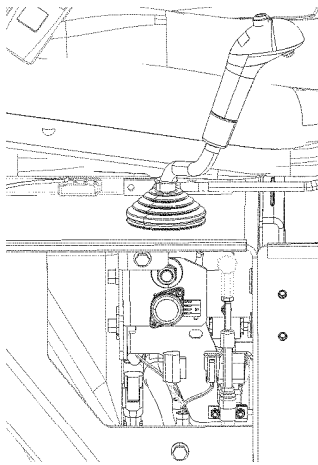
**Hand in the drained oil and filter to an environment-friendly waste disposal station.**



**Fig. Engine compartment  
2. Oil filter**



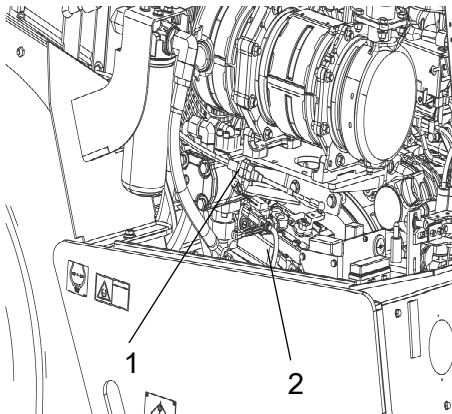
### Forward/Reverse controls and joints - Check and lubrication



**Fig. Forward/reverse lever**

The forward/reverse lever joints are best accessed via the compartment for the manual on the right side of the operator station. Check the friction on the forward/reverse lever. The friction screws should be applied sufficiently hard that the forward/reverse lever remains in the set position during operation. The lever's 0-position is determined by the screw that grips in the groove on the axle between the lever.

If the lever begins to become stiff after prolonged used, lubricate the lever at the control cable with a few drops of oil at each point.



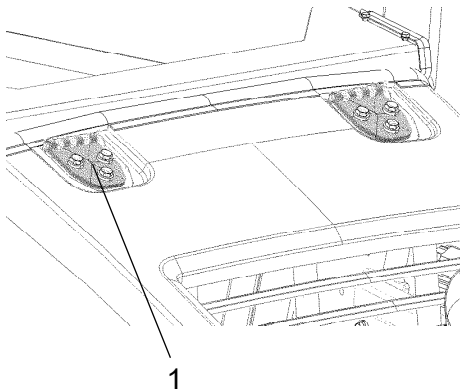
**Fig. Engine compartment**  
1. Forward/Reverse-control cable  
2. Propulsion pump

If the forward/reverse lever still is stiff after the above adjustments, lubricate the other end of the control cable with a few drops of oil. The cable is located on the top of the propulsion pump.



### Controls and moving joints - Lubrication

Lubricate the engine hood hinges (1) with grease, the other joints and controls are lubricated with oil. See lubricant specification.



**Fig. Engine hood**  
**1. Hinge**



### Hydraulic filter - Replacement

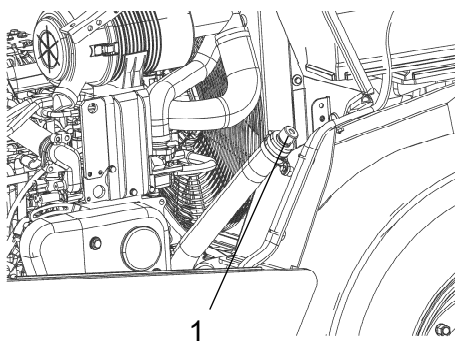
Release the filler cap/breather filter (1) so that any overpressure inside the reservoir is eliminated.

Check that the breather filter (1) is not clogged. Air should be able to pass freely through the cap in both directions.

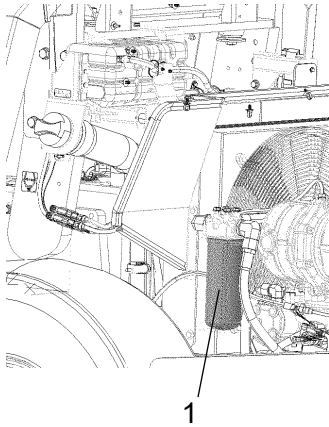
If passage in either direction is blocked, clean the filter with a little diesel oil and blow through with compressed air until the block is removed, or replace the cap with a new one.



***Wear protective goggles when working with compressed air.***



**Fig. Hydraulic reservoir**  
**1. Filler cap/Breather filter**



**Fig. Engine compartment**  
**1. Hydraulic fluid filter (1pc).**

Carefully clean round the filter.



Remove the oil filter (1) and hand in to an environment-friendly waste disposal station. This is a disposable filter and cannot be cleaned.



Make sure that the old sealing ring is not left on the filter holder. Otherwise, this could cause leakage between the new and old seal.

Thoroughly clean the sealing surfaces on the filter holder.

Apply a thin coat of fresh hydraulic fluid to the seals on the new filter. crew tight the filter by hand.



First tighten the filter until its seal is in contact with the filter attachment. Then turn an additional half revolution. Do not tighten the filter too hard as this could damage the gasket.

Start the engine and check that there is no leakage of hydraulic fluid from the filter. Check the fluid level in the sight glass and top up if necessary.



**Ensure that there is good ventilation (air extraction) if the engine is run indoors. Risk of carbon monoxide poisoning.**



### Fuel tank - Cleaning

It is easiest to clean the tank when it is almost empty.

Pump out any bottom sediment using a suitable pump, such as an oil drain pump.



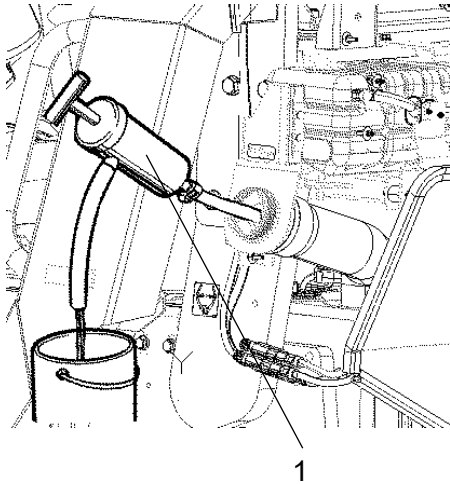
Collect the fuel and sediment in a container and deliver to environmentally correct handling.



**Keep in mind fire risk when handling fuel.**



The fuel tank is made of plastic (polyethylene) and is recyclable.



**Fig. Fuel tank**  
**1. Oil drain pump**

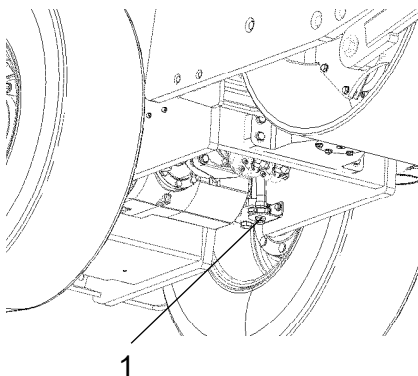


### Fuel tank - Draining (Equipment status)

Water and sediment in the fuel tank are drained out via the drain plug (1) in the bottom of the fuel tank.



**Be very careful during draining. Do not drop the plug or else all the fuel will flow out.**



**Fig. Left underside of the machine**  
**1. Drain plug**

Drain the roller after it has been stationary for a long time, e.g. after standing overnight. The fuel level should be as low as possible.

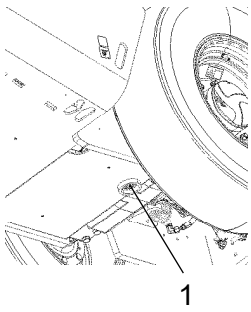
The roller should preferably have been standing with the drain plug somewhat lower, so that water and sediment collect at the drain plug (1). Drain as follows:

Place a container under the plug (1).

Undo the drain plug (1) and drain out water and sediment until only pure diesel fuel comes out at the plug. Screw in the plug again.



### Hydraulic reservoir - Draining



**Fig. Hydraulic reservoir, bottom**  
**1. Drain plug**

Condensate in the hydraulic reservoir is drained via the drain plug (1).

Drain the roller after it has been stationary for a long time, e.g. after standing overnight. Drain as follows:

Place a container under the drain hole.

Remove the plug (1).

Drain off any condensate.

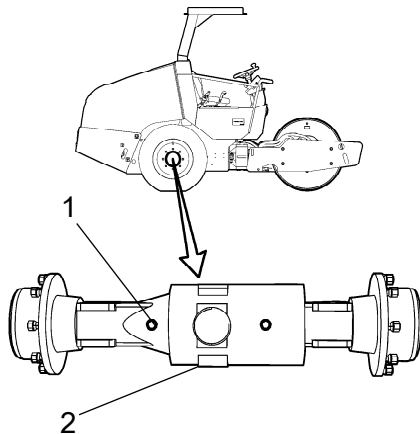
Refit the plug.



### Rear axle differential - Oil change



**Never work under the roller when the engine is running. Park on a level surface. Block the wheels securely.**



**Fig. Rear axle**  
**1. Level/Filler plug**  
**2. Drain plug**

Wipe clean and remove the filler/level plug (1) and the drain plug (2). The drain plug (2) is on the back of the shaft. Drain the oil into a container. The volume is approx. 4.5 liters (4.2 qts).



Save the oil and hand in to an environment-friendly waste disposal station.

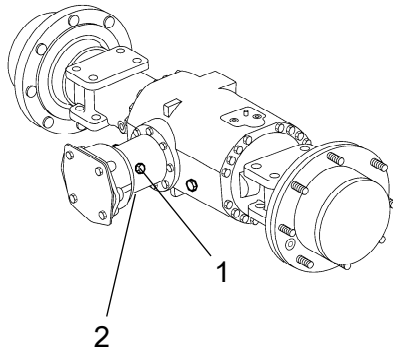
Replace the drain plug and top up with fresh oil to the correct level. Replace the level/filler plug. Use transmission oil, see the lubricant specification.



### Rear axle pinion housing - Oil change



**Never work under the roller when the engine is running. Park on a level surface. Block the wheels securely.**



Wipe clean and remove the level/filler plug (1) and the drain plug (2). The drain plug (2) is on the underside of the pinion housing. Drain off the oil into a container. The volume is approx. 0.3 liters (0.32 qts).



Save the oil and hand in to an environment-friendly waste disposal station.

**Fig. Rear axle**  
1. Level/Filler plug  
2. Drain plug

Replace the drain plug and top up with fresh oil to the correct level. Replace the level/filler plug. Use transmission oil, see the lubricant specification.



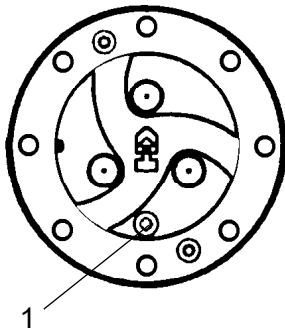
### Rear axle planetary gear - Oil change

Position the roller with the plug (1) at its lowest position.

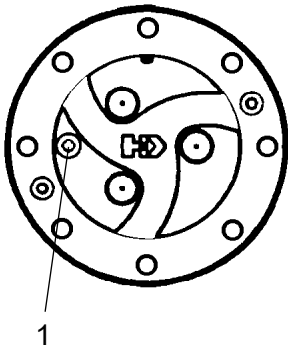
Wipe clean, unscrew the plug (1) and drain the oil into a suitable receptacle. The volume is approx. 0,9 liters (0,95 qts)/side.



Save the oil and hand in to an environment-friendly waste disposal station.



**Fig. Planetary gear/drainage position**  
1. Plug



Position the roller with the plug (1) in the planetary gear in the "9 o'clock" position.

Fill with oil to lower edge of level hole. Use transmission oil. See the lubrication specification.

Clean and refit the plug.


Check the fluid level in the same way on the rear axle's other planetary gear.


*Fig. Planetary gear/filling position*  
**1. Plug**



### Maintenance - 2000h

Performed after 2000 operating hours (every two years)


 **Park the roller on a level surface. The engine must be switched off and the parking brake activated when checking or adjusting the roller, unless otherwise specified.**

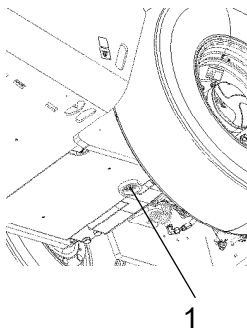
 **Ensure that there is good ventilation (air extraction) if the engine is run indoors. Risk of carbon monoxide poisoning.**



### Hydraulic reservoir - Oil change


Use a container to collect the used fluid. The container should hold at least 45 liters (11.8 gal).

 **Observe caution when draining hot hydraulic fluid. Wear protective gloves and goggles.**



**Fig. Hydraulic reservoir, bottom  
1. Drain plug**

Place the container under the hydraulic reservoir. Remove the drain plug (1) and allow the fluid to run down into the container. Wipe clean and replace the drain plug (1) in the hydraulic reservoir.

 **Save the oil and hand in to an environment-friendly waste disposal station.**

Fill up with fresh hydraulic fluid as per the instructions under the heading "Hydraulic reservoir - Check fluid level". Replace the hydraulic fluid filter at the same time.

Start the diesel engine and operate the various hydraulic functions.

Check the fluid level and top up if necessary.



### Forward/Reverse controls and joints - Check and lubrication

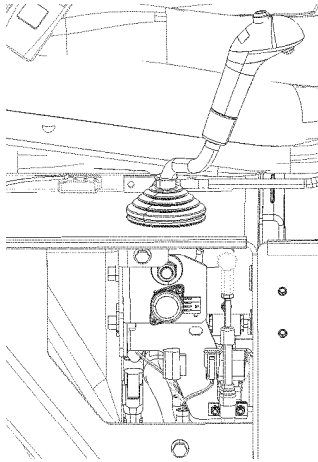


Fig. Forward/reverse lever

The forward/reverse lever joints are best accessed via the compartment for the manual on the right side of the operator station. Check the friction on the forward/reverse lever. The friction screws should be applied sufficiently hard that the forward/reverse lever remains in the set position during operation. The lever's 0-position is determined by the screw that grips in the groove on the axle between the lever.

If the lever begins to become stiff after prolonged used, lubricate the lever at the control cable with a few drops of oil at each point.



### Battery - Check condition

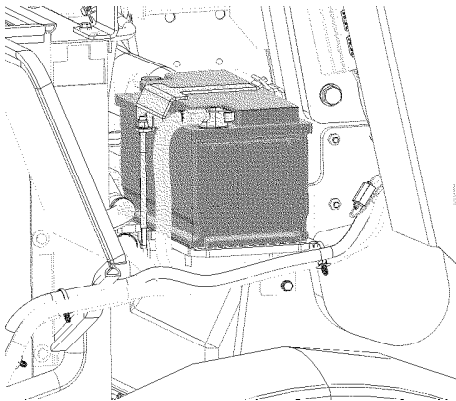


Fig. Battery

The batteries are sealed and maintenance-free.



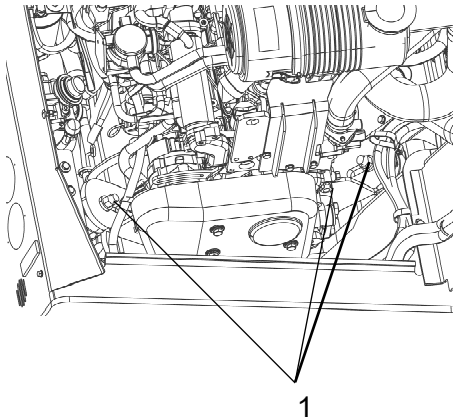
***Make sure there is no open flame in the vicinity when checking the electrolyte level. Explosive gas is formed when the alternator charges the battery.***



**When disconnecting the battery, always disconnect the negative cable first. When connecting the battery, always connect the positive cable first.**

The cable shoes should be clean and tightened. Corroded cable shoes should be cleaned and greased with acid-proof Vaseline.

Wipe the top of the battery.



**Fig. Engine suspension**  
**1. Bolted joint**

### Bolted joints - Checking tightening torque

Check that all the bolts for the suspension of the engine and the drive unit are tightened, see under Specifications - tightening torque.

Check the bolted joint between the motor and the pump drive, and that all the hydraulic components are tightened to the set tightening torque.

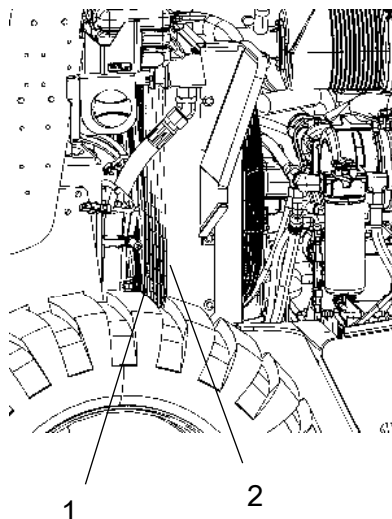
(The above applies to new or replaced components only).



### Coolers Checking - Cleaning

Make sure that the air flow through the coolers (1) and (2) is unobstructed. Dirty coolers are blown clean with compressed air or washed clean using a high-pressure water cleaner.

Blow air or direct water through the cooler in the opposite direction to that of the cooling air.



**Fig. Engine compartment**  
**1. Water cooler**  
**2. Hydraulic fluid cooler**



Take care when using a high-pressure water jet. Do not hold the nozzle too near the cooler.



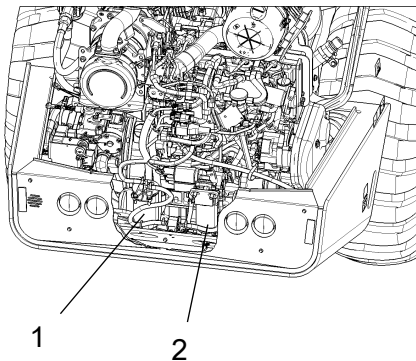
**Wear protective goggles when working with compressed air or high-pressure air jets.**



### The engine fuel filter - replacement/cleaning



Place a container underneath to collect fuel that runs out when the filter is released.



**Fig. Engine compartment**  
1. Fuel filter  
2. Fuel prefilter

Screw off the fuel filter (1). The filter is of the disposable type and cannot be cleaned. Hand in to environment-friendly station.

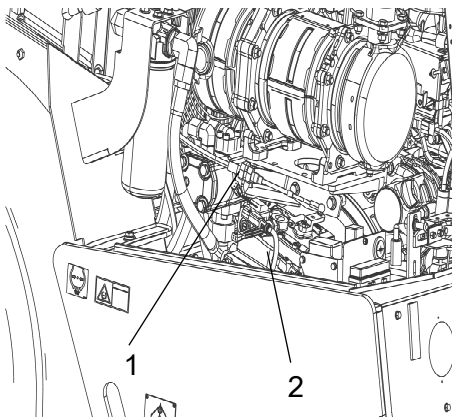


Refer to the engine manual for detailed instructions when replacing the fuel filter.

Unscrew the lower part of the fuel prefilter (2) and drain off any water, and then replace the filter unit.

Start the engine and check that the fuel filters are tight.

**N.B.** Under no circumstances may new fuel filters be pre-filled with fuel before assembly due to the demands on the cleanliness of the fuel system. Use the hand pump on the fuel prefilter to fill from the machine's fuel system.



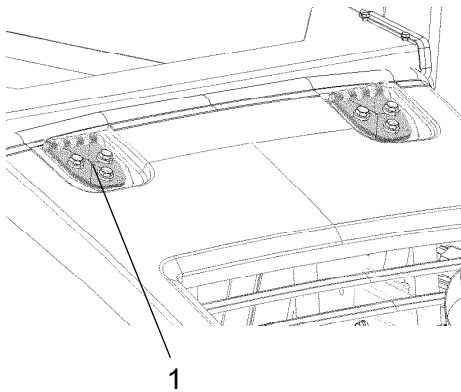
**Fig. Engine compartment**  
1. Forward/Reverse-control cable  
2. Propulsion pump

If the forward/reverse lever still is stiff after the above adjustments, lubricate the other end of the control cable with a few drops of oil. The cable is located on the top of the propulsion pump.



### Controls and moving joints - Lubrication

Lubricate the engine hood hinges (1) with grease, the other joints and controls are lubricated with oil. See lubricant specification.



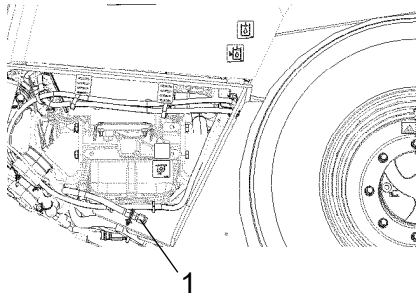
**Fig. Engine hood**  
**1. Hinge**



## Diesel engine - Oil- and Filter change



**Take great care when draining warm fluid and oil.  
Wear protective gloves and goggles.**



**Fig. Right side of engine  
1. Drain plug**

The oil plug (1) is most easily accessible from the underside of the engine, and is fitted with a hose on the tractor frame.

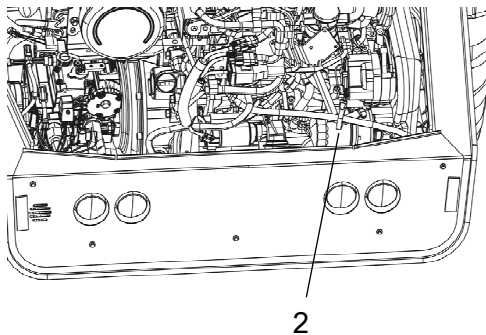
Place a receptacle that holds 15 liters (4 gal) under the drain plug.

Release the hose from its attachment and pull it forward to the tie-down hole.

Loosen the drain plug (1) and drain the oil, when the engine is warm.

Screw back the plug again and refit the hose in its attachment.

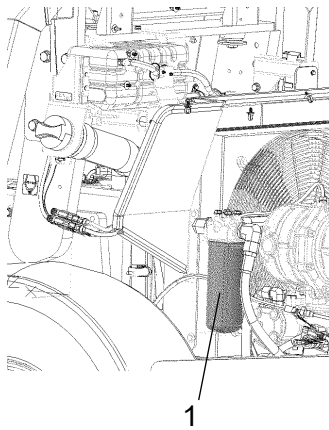
Change the engine oil filter (2) at the same time. Refer also to the Instruction Manual for the engine.



**Fig. Engine compartment  
2. Oil filter**



**Hand in the drained oil and filter to an  
environment-friendly waste disposal station.**



**Fig. Engine compartment**  
**1. Hydraulic fluid filter (1pc).**

Carefully clean round the filter.



Remove the oil filter (1) and hand in to an environment-friendly waste disposal station. This is a disposable filter and cannot be cleaned.



Make sure that the old sealing ring is not left on the filter holder. Otherwise, this could cause leakage between the new and old seal.

Thoroughly clean the sealing surfaces on the filter holder.

Apply a thin coat of fresh hydraulic fluid to the seals on the new filter. crew tight the filter by hand.

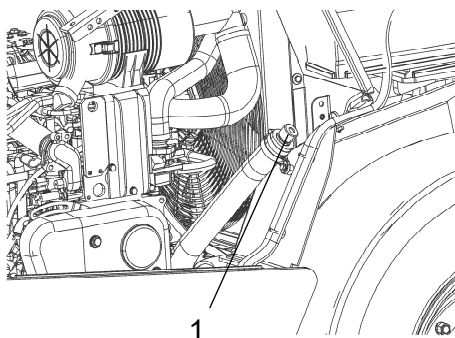


First tighten the filter until its seal is in contact with the filter attachment. Then turn an additional half revolution. Do not tighten the filter too hard as this could damage the gasket.

Start the engine and check that there is no leakage of hydraulic fluid from the filter. Check the fluid level in the sight glass and top up if necessary.



**Ensure that there is good ventilation (air extraction) if the engine is run indoors. Risk of carbon monoxide poisoning.**



**Fig. Hydraulic reservoir**  
**1. Filler cap/Breather filter**

### Hydraulic filter - Replacement

Release the filler cap/breather filter (1) so that any overpressure inside the reservoir is eliminated.

Check that the breather filter (1) is not clogged. Air should be able to pass freely through the cap in both directions.

If passage in either direction is blocked, clean the filter with a little diesel oil and blow through with compressed air until the block is removed, or replace the cap with a new one.



**Wear protective goggles when working with compressed air.**



### Fuel tank - Cleaning

It is easiest to clean the tank when it is almost empty.

Pump out any bottom sediment using a suitable pump, such as an oil drain pump.



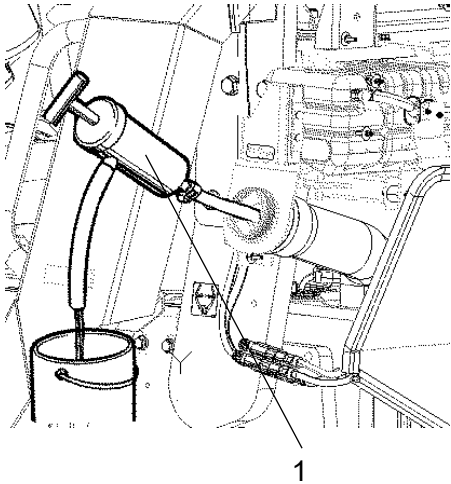
Collect the fuel and sediment in a container and deliver to environmentally correct handling.



**Keep in mind fire risk when handling fuel.**



The fuel tank is made of plastic (polyethylene) and is recyclable.



**Fig. Fuel tank**  
**1. Oil drain pump**

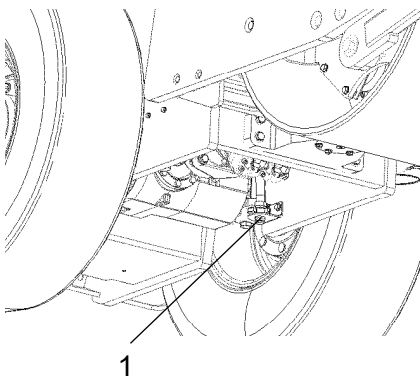


### Fuel tank - Draining (Equipment status)

Water and sediment in the fuel tank are drained out via the drain plug (1) in the bottom of the fuel tank.



**Be very careful during draining. Do not drop the plug or else all the fuel will flow out.**



**Fig. Left underside of the machine**  
**1. Drain plug**

Drain the roller after it has been stationary for a long time, e.g. after standing overnight. The fuel level should be as low as possible.

The roller should preferably have been standing with the drain plug somewhat lower, so that water and sediment collect at the drain plug (1). Drain as follows:

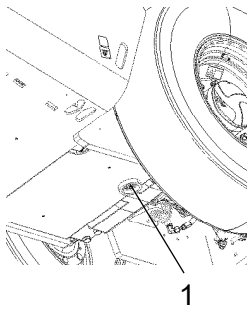
Place a container under the plug (1).

Undo the drain plug (1) and drain out water and sediment until only pure diesel fuel comes out at the plug. Screw in the plug again.





### Hydraulic reservoir - Draining



**Fig. Hydraulic reservoir, bottom**  
**1. Drain plug**

Condensate in the hydraulic reservoir is drained via the drain plug (1).

Drain the roller after it has been stationary for a long time, e.g. after standing overnight. Drain as follows:

Place a container under the drain hole.

Remove the plug (1).

Drain off any condensate.

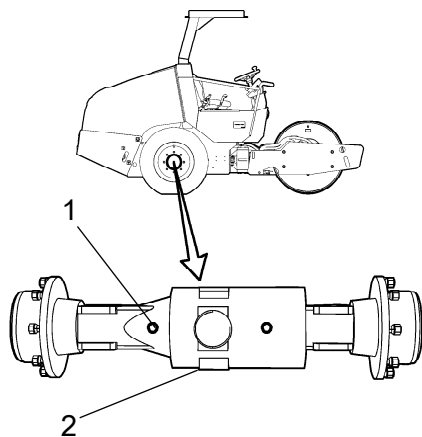
Refit the plug.



### Rear axle differential - Oil change



**Never work under the roller when the engine is running. Park on a level surface. Block the wheels securely.**



**Fig. Rear axle**  
**1. Level/Filler plug**  
**2. Drain plug**

Wipe clean and remove the filler/level plug (1) and the drain plug (2). The drain plug (2) is on the back of the shaft. Drain the oil into a container. The volume is approx. 4.5 liters (4.2 qts).

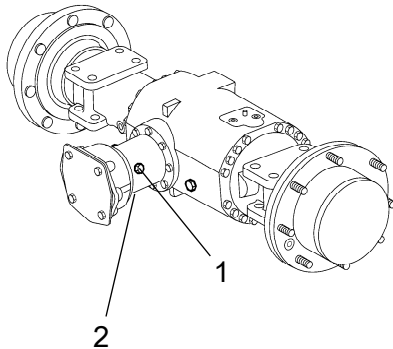


Save the oil and hand in to an environment-friendly waste disposal station.

Replace the drain plug and top up with fresh oil to the correct level. Replace the level/filler plug. Use transmission oil, see the lubricant specification.



### Rear axle pinion housing - Oil change



**Never work under the roller when the engine is running. Park on a level surface. Block the wheels securely.**

Wipe clean and remove the level/filler plug (1) and the drain plug (2). The drain plug (2) is on the underside of the pinion housing. Drain off the oil into a container. The volume is approx. 0.3 liters (0.32 qts).



Save the oil and hand in to an environment-friendly waste disposal station.

**Fig. Rear axle**  
1. Level/Filler plug  
2. Drain plug

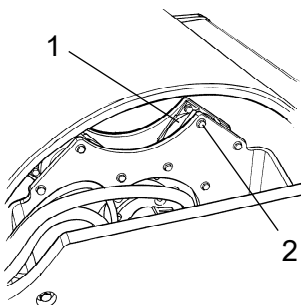
Replace the drain plug and top up with fresh oil to the correct level. Replace the level/filler plug. Use transmission oil, see the lubricant specification.

### Rubber elements and fastening screws - Check

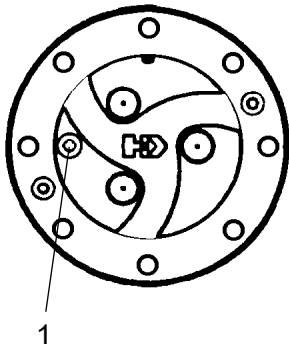
Check all rubber elements (1), replace all of the elements if more than 25% of them on one side of the drum are cracked deeper than 10-15 mm (0.4-0.6 in).

Check using a knife blade or pointed object.

Check also that the screws (2) are tightened.



**Fig. Drum, vibration side**  
1. Rubber element  
2. Screws



**Fig. Planetary gear/filling position**  
**1. Plug**

Position the roller with the plug (1) in the planetary gear in the "9 o'clock" position.

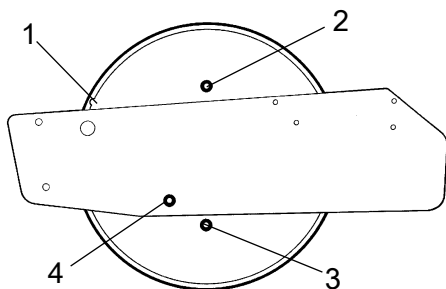
Fill with oil to lower edge of level hole. Use transmission oil. See the lubrication specification.

Clean and refit the plug.

Check the fluid level in the same way on the rear axle's other planetary gear.



### Drum - Oil change



**Fig. Drum, left side**  
**1. Groove**  
**2. Filler plug**  
**3. Drain plug/Magnetic plug**  
**4. Level plug**

Position the roller on a flat surface with the groove (1) on the inside of the drum aligned with the top of the drum frame.

Place a receptacle that holds 10 liters (2.6 gal) under the drain plug (3).

Clean and unscrew the filler plug (2) and drain plug (3), and allow all the oil to run out.



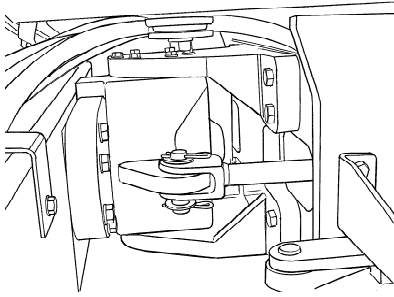
**Take great care when draining warm fluids and oils. Wear protective gloves and goggles.**



Save the oil and hand in to an environment-friendly waste disposal station.

Clean and refit the drain plug (3) and fill with oil as per "Drum - Checking the oil level".

Clean and refit the filler plug (2).



**Fig. Steering joint**

### Steering joint - Check

Inspect the steering joint to detect any damage or cracks.

Check and tighten any loose bolts.

Check also for any stiffness and play.



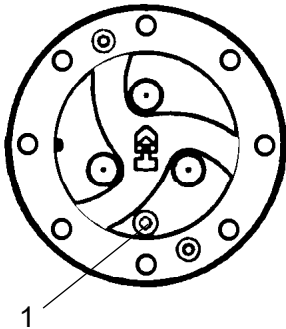
### Rear axle planetary gear - Oil change

Position the roller with the plug (1) at its lowest position.

Wipe clean, unscrew the plug (1) and drain the oil into a suitable receptacle. The volume is approx. 0,9 liters (0,95 qts)/side.



Save the oil and hand in to an environment-friendly waste disposal station.



**Fig. Planetary gear/drainage position**  
**1. Plug**



