

OPERATING INSTRUCTIONS

**DINO
280RXT**

Manufacturer:

Dinolift Oy
Raikkolantie 145 | FI-32210 LOIMAA
Tel. + 358 20 1772 400 | info@dinolift.com | www.dinolift.com

ORIGINAL OPERATING INSTRUCTIONS**Valid from serial number:****280RXT 80001 -->**

SERIAL NUM.	CHANGE	DATE
	Auto levelling change	24.5.2018

TABLE OF CONTENTS

1.	TO THE OPERATOR	7
1.1.	OVERVIEW OF THE UNIT.....	8
1.2.	INTENDED USE OF THE WORK PLATFORM.....	8
2.	TECHNICAL SPECIFICATION	9
2.1.	DIMENSION DRAWINGS.....	10
2.2.	REACH DIAGRAM.....	11
2.3.	EXAMPLE OF MACHINE'S NAMEPLATE.....	12
2.4.	MODEL OF EC-DECLARATION OF CONFORMITY.....	13
2.5.	MODEL OF INSPECTION PROTOCOL FOR THE ACCESS PLATFORM.....	14
3.	SAFETY	16
3.1.	SAFETY INSTRUCTIONS.....	16
3.2.	SAFETY-RELATED NOTIFICATIONS.....	20
3.3.	SAFETY DEVICES.....	22
4.	BASIC STRUCTURE AND FUNCTIONS	28
4.1.	STRUCTURE.....	28
4.2.	BASIC FUNCTIONS.....	29
4.3.	OPERATING CONTROLS.....	30
4.3.1.	Platform panel UCB.....	32
4.3.2.	Display.....	33
4.3.3.	Chassis control panel LCB.....	36
5.	OPERATION	37
5.1.	START-UP.....	37
5.1.1.	Worksite inspection.....	37
5.2.	INSTRUCTIONS FOR WORKING.....	39
5.2.1.	Driving.....	41
5.2.2.	Support position.....	43
5.2.3.	Operating the boom from the platform.....	46
5.2.4.	Operating the boom from the chassis panel.....	48
5.2.5.	Measures to be taken at the end of the working day.....	49
5.2.6.	Special instructions for winter use.....	49
5.3.	IN CASE OF EMERGENCY.....	50
5.3.1.	When at risk of losing stability.....	50
5.3.2.	In case the power supply is interrupted (power unit / combustion engine).....	50
5.3.3.	In case the emergency descent battery is empty.....	51
5.3.4.	In case of malfunctioning control system.....	52
5.4.	LONG-TERM STORAGE.....	54
5.5.	INSTRUCTIONS FOR TRANSPORT.....	54
5.5.1.	Tying down.....	54
5.5.2.	Lifting.....	55
5.5.3.	Shortened transport position.....	56

6.	DINO SKY RACK (OPTION)	57
7.	DINO SAFE-GUARD (OPTION)	59
8.	FAULT FINDING	60
	8.1. OPERABILITY OF MOVEMENTS	61
	8.2. FAULT CODES	62
9.	SERVICING AND MAINTENANCE	64
	9.1. LUBRICATION PLAN	66
	9.2. INSPECTIONS REQUIRED BY AUTHORITIES	68
10.	ROUTINE MAINTENANCE DURING OPERATION	69
	10.1. DAILY MAINTENANCE TASKS	70
	10.1.1. Chassis, boom and work platform	70
	10.1.2. Check the tyres	70
	10.1.3. Check the fuel and hydraulic oil levels	70
	10.1.4. Check the electrical and hydraulic systems	70
	10.1.5. Check the status of control system	71
	10.1.6. Check the emergency descent, emergency stop and sound signal	71
	10.1.7. Signs, labels and machine plates	71
	10.1.8. Instruction manuals	71
11.	CHANGE OF OWNER	73

1. TO THE OPERATOR

Keep this manual on the work platform of the lift in the box reserved for it. If the instruction manual gets lost, damaged, or for some other reason becomes unreadable, order a new manual from the manufacturer.

This manual is intended to familiarise the user with the structure and functions of the work platform, as well as with its appropriate use. The manual provides guidance on the service measures that are the responsibility of the user of the work platform.

Other maintenance procedures on the work platform require special skills, special tools or accurate knowledge about measurements or adjusted values. Guidance for these measures is provided in a separate service manual. For situations that require service or repair measures, contact the authorised service provider, importer or manufacturer.



DANGER

Read all the instructions in this manual before using the aerial work platform. Make sure that you have understood all the instructions. The instructions must absolutely be followed during operation and maintenance of the aerial work platform.

When handling the unit, in addition to the instructions in this manual, the user must also observe the local legislation, the guidelines stipulated by the employer, and regulations valid at the work site.

Dinolift Oy is constantly developing its products. For this reason, the contents of this manual might not always be in full compliance with the most recent version of the product. Dinolift Oy reserves the right to modify the product without prior notice. Dinolift Oy assumes no liability for any problems caused by changed or missing data or mistakes in this manual.

Please consult your dealer or the manufacturer for more information and detailed instructions.

NOTICE

USA only

Dealers, installers, owners, users, operators, lessors, lessees and brokers must fulfill the responsibilities stated in the manual of responsibilities according to ANSI92.5 standard for boom-supported elevating work platforms.

1.1. OVERVIEW OF THE UNIT

The unit is a wheeled, self-propelled aerial work platform. This aerial work platform complies with the standard EN280 type 1, where driving is only allowed while the boom is in transport position. The boom supported aerial work platform is operated from the control station on the platform.

For lifting the unit is supported by its hydraulic stabilisers. They must be extended so that the unit's wheels lift off the ground.

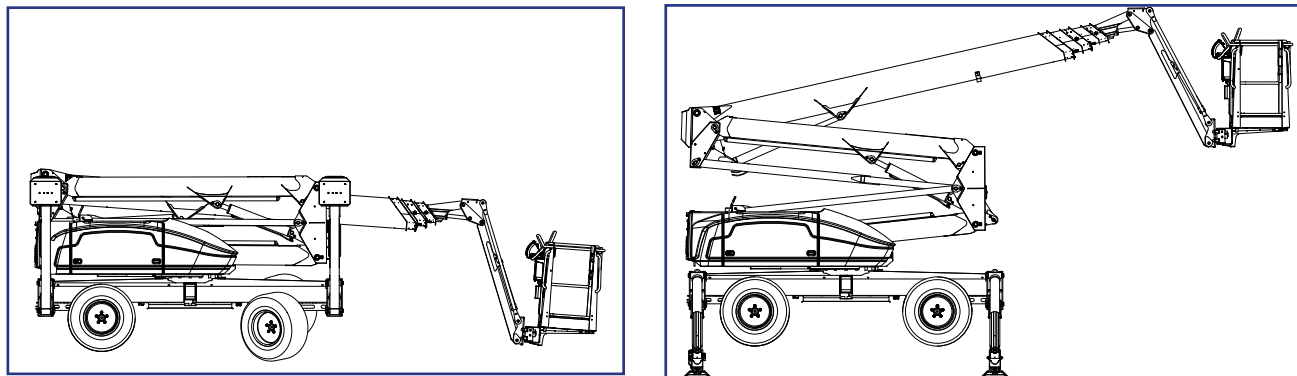

The lift's primary power source is a diesel engine. A mains-powered electric motor is available as an auxiliary power source. The stabilisers and the boom system are hydraulically powered.

Consult the chapters "Technical data" and "Structure and functions of the work platform" in this manual for more detailed information about the lift.

1.2. INTENDED USE OF THE WORK PLATFORM

The aerial work platform is exclusively intended for transferring people and tools and acting as a work platform within its permissible load-bearing capacity and reach (refer to the "Technical Specifications" table and the "Reach Diagram").

The intended use also covers:

- Following all the instructions in the Operating Instructions
- Performance of the inspections and maintenance operations.

This aerial work platform is NOT insulated, and does not offer protection against contact with electric current. The aerial work platform must not be used for work on electric systems.

Observe the safety instructions concerning the operating environment, and the restrictions given in them,

NOTICE

The operator must receive instructions and consent from the manufacturer for all such specific work methods or conditions that the manufacturer has not explicitly defined in the unit's operation and maintenance instructions.

2. TECHNICAL SPECIFICATION

		280RXT
Max. working height		28,0 m (91 ft 10")
Max. platform height		26,0 m (85 ft 4")
Max. outreach		16,0 m (52 ft 6")
Boom rotation		continuous
Platform rotation		180°
Jib arms		1,6m (63") / 140°
Turn area		refer to the reach diagram
Support width		3,8 m x 4,2 m (12 ft 6" x 13 ft 9")
Transport width		2,05 m (80")
Transport length		5,8 m (19 ft 1")
Transport height		2,4 m (7 ft 9")
Weight		4860 kg (10715 lbs)
Max. allowed load on platform		230 kg (507 lbs)
Max. number of persons + additional load		2 persons + 70 kg (154 lb)
Max. allowed sideways load (caused by persons)		400 N (100 lbf)
Max. lateral inclination (chassis)		±1°
Max. wind speed during operation		12,5 m/s (28 mph)
Min. ambient temperature when working		- 20 °C (-4 °F)
Max. support force on the stabilisers		29 000 N (6520 lbf)
Platform size		0,7 x 1,3 m (2ft 4" x 4ft 3")
Driving speed		max. 10 km/h (4,2 mph)
Gradeability		40% (22°)
Power supply		
- Combustion engine (Diesel)		KUBOTA D1105 (EPA / CARB Tier 4 Final)
	Net power	18,5 kW (24,8 hv) / 2800 r/min
	Fuel tank volume	82 l (22 gal)
	Oil volume	5,1 l (5,3 qt)
	Coolant volume	3,1 l (3,3 qt)
	Quaranteed sound power level Lwa	102 dB
	Sound pressure level (UCB/LCB)	72 / 85 dB
	Whole-body vibration (driving/high speed)	1,0 m/s ²
	Whole-body vibration (work, driving/low speed)	< 0,5 m/s ²
- Mains current (optional)		230/50Hz/16A
	Sound pressure level	< 70 dB
	Whole-body vibration	not detectable
Socket outlets on the platform		2 x 230V/50Hz/16A
		12V
		USB

2.1. DIMENSION DRAWINGS

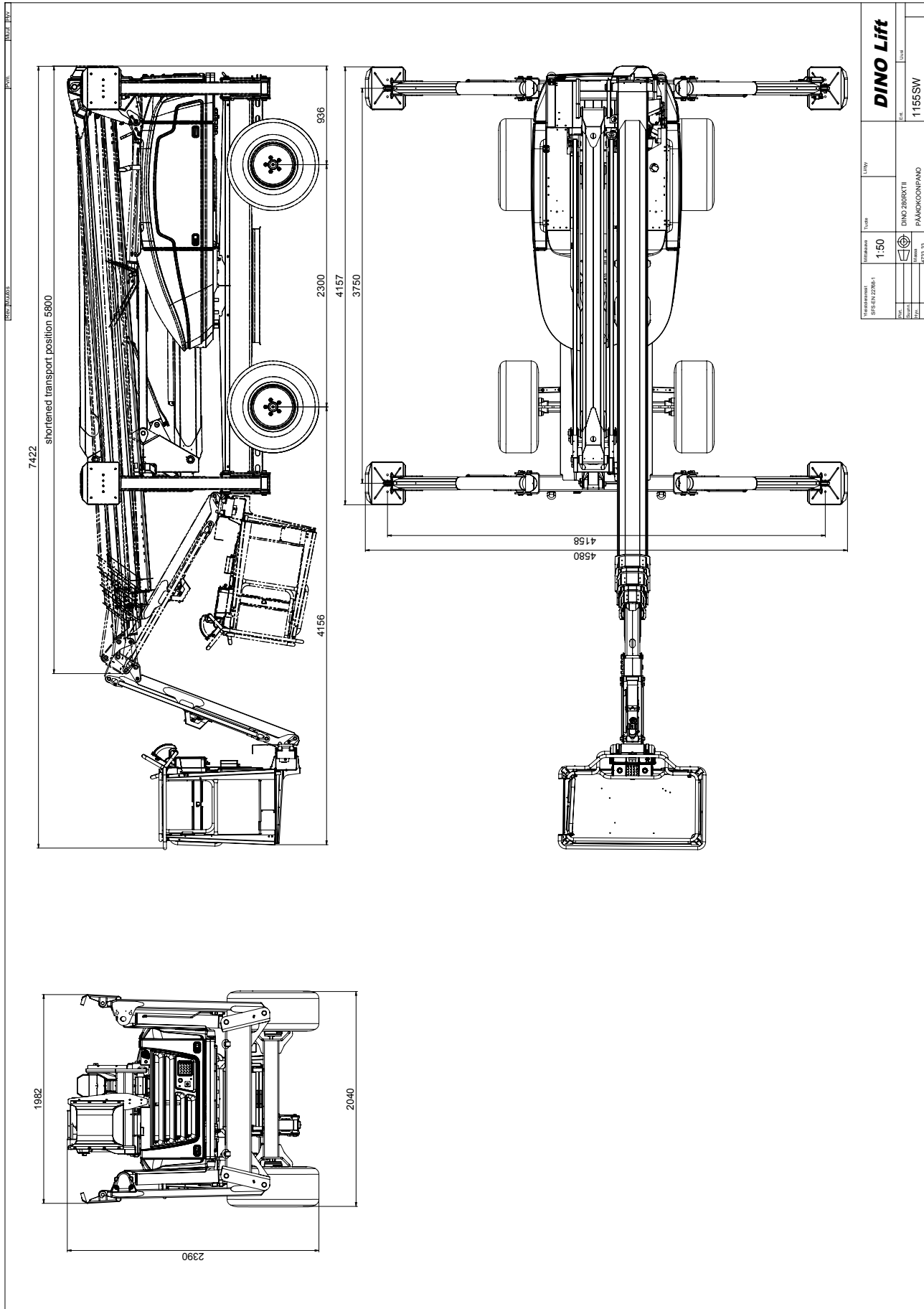

2.2. REACH DIAGRAM

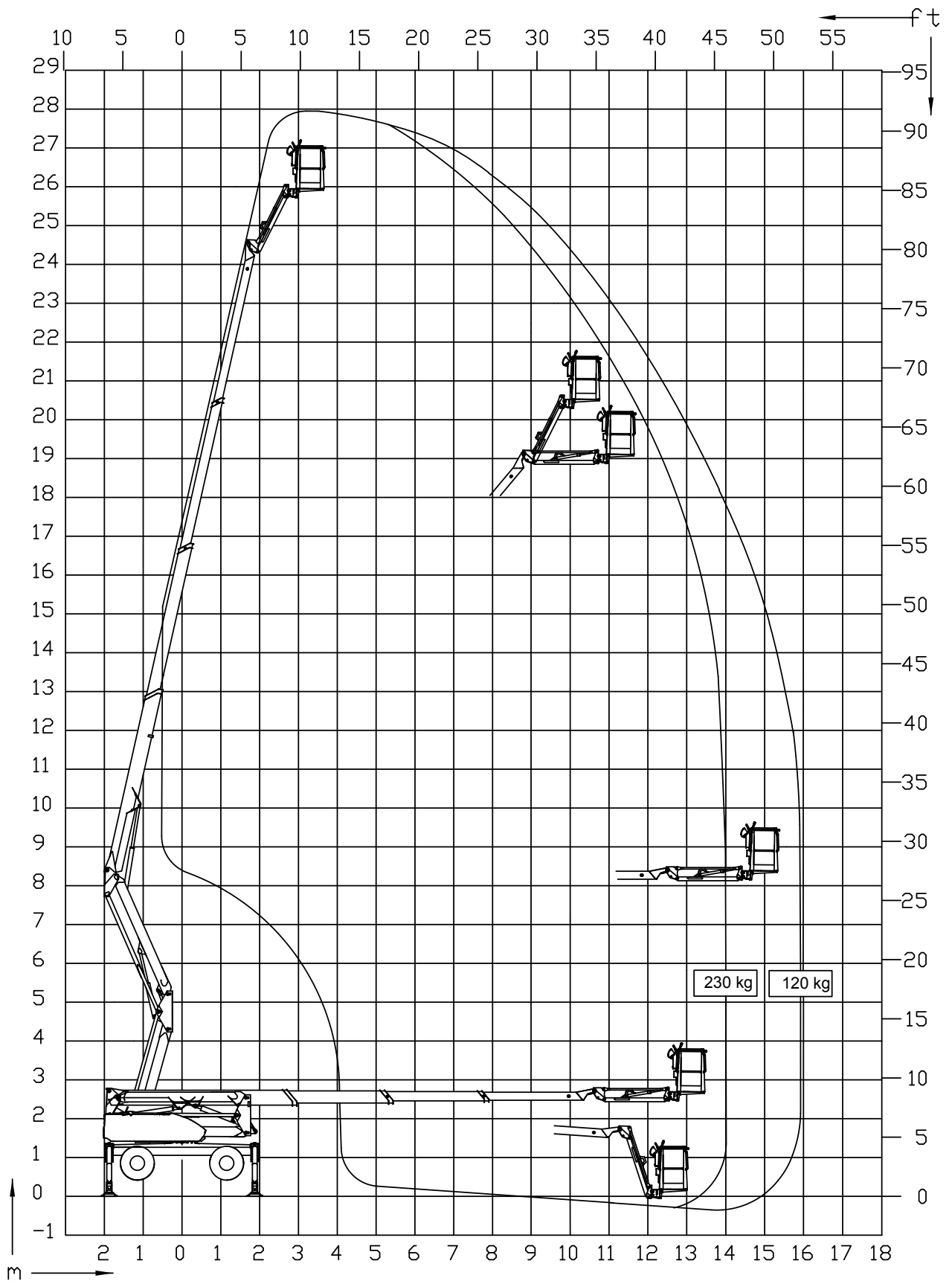

2.3. EXAMPLE OF MACHINE'S NAMEPLATE

Every machine has a nameplate shown in the picture below. In the nameplate are marked the name and address of machine manufacturer, serial number of the machine and other relevant machine information.

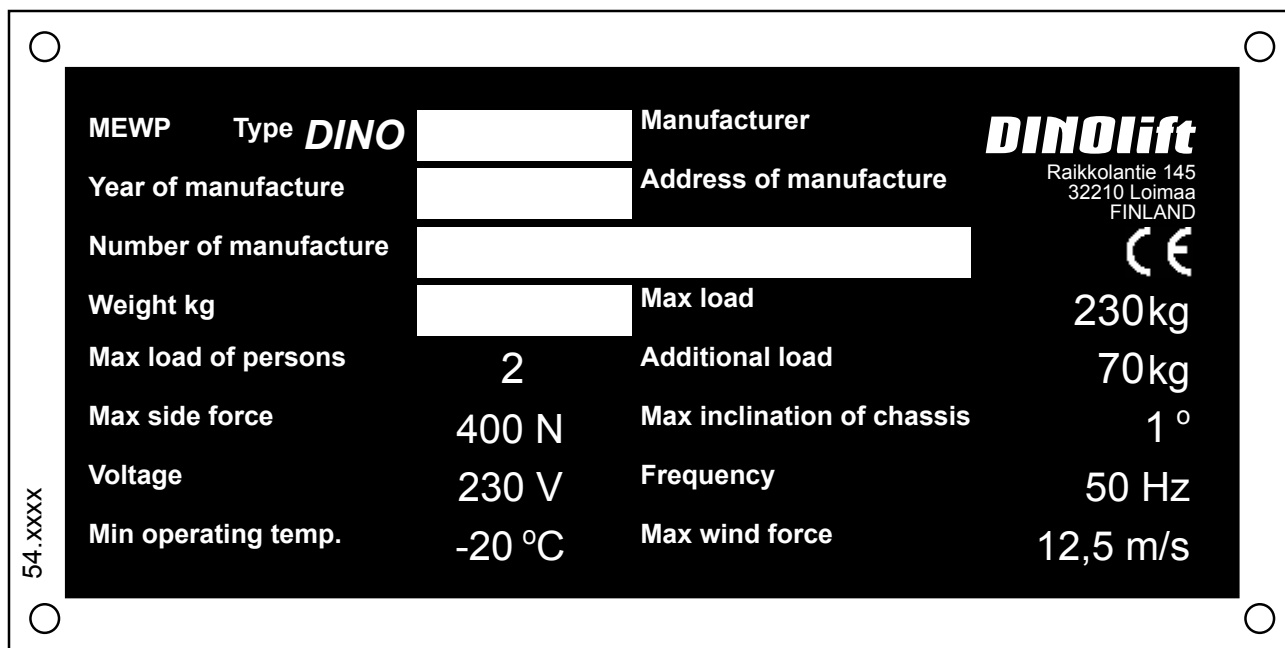

Description of the machine: MEWP = “Mobile Elevating Work Platform”.

The nameplate and machine inspection plate are located as shown in the picture.

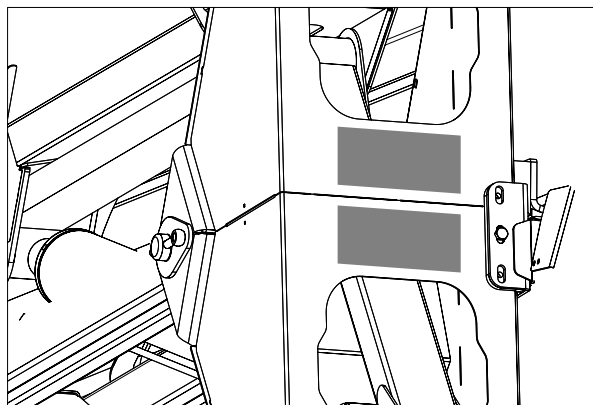

The serial number is also engraved in the chassis.

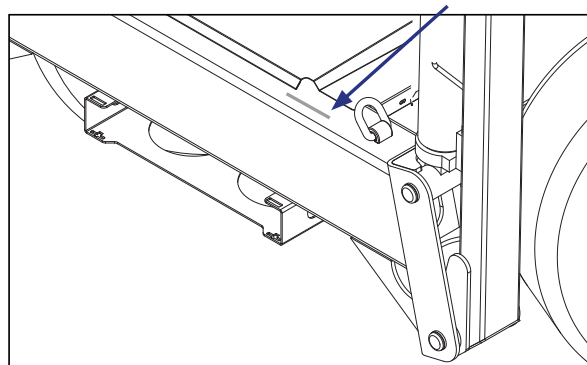

2.4. MODEL OF EC-DECLARATION OF CONFORMITY**EC-Declaration of Conformity for Machinery****Manufacturer**

Dinolift Oy
Raikkolantie 145
FI-32210 Loimaa, FINLAND

declares that

DINO 280RXT Access Platform no YGC280RXTK0080030

is in conformity with the provisions of Machinery Directive **2006/42/EC** as amended and with national implementing legislation.

2006/42/EC Conformity assessment procedure followed: Annex VIII: internal control of production.

Access platform also fulfils the requirements of the following EC directives:

2000/14/EC, 2014/30/EU

Measured sound power level L_{wa}	(100 + 1,5) 101,5 dB
Quaranteed sound power level L_{wa}	101,5 + 0,5 dB

2000/14/EC Conformity assessment procedure followed: Annex V: Internal control of production.

Following harmonized standards have been applied in designing the machine:

SFS-EN 280:2015; EN 13849-1:2015; SFS-EN 60204-1/A1; SFS-EN-ISO 12100:2010

Person authorized to draw up the Technical File:

Santtu Siivola
Chief Engineer
Dinolift Oy, Raikkolantie 145,
32210 Loimaa, FINLAND

Loimaa 30.06.2017

Santtu Siivola
Chief Engineer

NOTICE! Unauthorized changes or significant repairs that affect strength, stability or operation of the machine will cause the CE marking and EC declaration of conformity to become invalid.

2.5. MODEL OF INSPECTION PROTOCOL FOR THE ACCESS PLATFORM

TEST CERTIFICATE

DATE:

START-UP TESTS:	
Inspection place: <u>Dinolift Oy</u>	Inspector's signature: <u>Schmidt Florian NT0578-2</u>

BASIC INFORMATION			
Manufacturer: <u>Dinolift OY</u>	Place of manufacture: <u>Finland</u>		
Address: <u>Raikkolantie 145</u> <u>32210 LOIMAA</u>			
Importer: _____			
Type of lift:	<input checked="" type="checkbox"/> Boom platform	<input type="checkbox"/> Scissor platform	<input type="checkbox"/> Mast platform
Chassis:	<input type="checkbox"/> Car	<input checked="" type="checkbox"/> Self propelled	<input type="checkbox"/> Trailer mounted
Boom:	<input type="checkbox"/> Articulated boom	<input type="checkbox"/> Telescopic boom	<input checked="" type="checkbox"/> Articulated telescopic boom
	<input type="checkbox"/> Fixed mast	<input type="checkbox"/> Telescopic mast	<input type="checkbox"/> Scissor
Outriggers:	<input checked="" type="checkbox"/> Hydraulic turning	<input type="checkbox"/> Hydraulic pushing	<input type="checkbox"/> Mechanical

TECHNICAL SPECIFICATIONS			
Machine and type:	<u>DINO 280RXT</u>	Max. platform height	<u>26,0 m</u>
Number of manufacture		Max. outreach:	<u>Depend on load</u>
Year of manufacture			
Max. lifting capacity:	<u>230 kg</u>	Boom rotation:	<u>Continuous</u>
Max. person number:	<u>2</u>	Support width:	<u>3,8 m</u>
Max. additional load:	<u>70kg</u>	Transport width:	<u>2,08 m</u>
Power supply:	<u>Diesel</u>	Transport length:	<u>5,82 m</u>
Lowest temperature:	<u>-20 °C</u>	Transport height:	<u>2,37 m</u>
Weight:	<u>4860 kg</u>	Basket size:	<u>0,7x1,3</u>

INSPECTION POINTS: (Y = meet standards N = do not meet standards)					
	Y	N		Y	N
A. GENERAL REQUIREMENTS			C. STRUCTURES		
1. Suitability for use	<input checked="" type="checkbox"/>	<input type="checkbox"/>	1. Transport position / transp. equipment	<input checked="" type="checkbox"/>	<input type="checkbox"/>
2. Certificate of conformity	<input checked="" type="checkbox"/>	<input type="checkbox"/>	2. Driving/towing equipment	<input checked="" type="checkbox"/>	<input type="checkbox"/>
3. User manual and storage	<input checked="" type="checkbox"/>	<input type="checkbox"/>	3. Chassis	<input checked="" type="checkbox"/>	<input type="checkbox"/>
4. Machine plate - inspection plate	<input checked="" type="checkbox"/>	<input type="checkbox"/>	4. Turning device	<input checked="" type="checkbox"/>	<input type="checkbox"/>
5. Instructional and safety plates	<input checked="" type="checkbox"/>	<input type="checkbox"/>	5. Boom system	<input checked="" type="checkbox"/>	<input type="checkbox"/>
6. Safety colours	<input checked="" type="checkbox"/>	<input type="checkbox"/>	6. Structure and position of work platform	<input checked="" type="checkbox"/>	<input type="checkbox"/>
			7. Hydraulic system	<input checked="" type="checkbox"/>	<input type="checkbox"/>
B. STABILITY			D. ELECTRIC SYSTEM		
1. Load plate and reach diagram	<input checked="" type="checkbox"/>	<input type="checkbox"/>	1. Electric system	<input checked="" type="checkbox"/>	<input type="checkbox"/>
2. Supports / outriggers	<input checked="" type="checkbox"/>	<input type="checkbox"/>	2. Electric appliances	<input checked="" type="checkbox"/>	<input type="checkbox"/>
3. Indicator for horizontal position	<input checked="" type="checkbox"/>	<input type="checkbox"/>	3. Lights	<input checked="" type="checkbox"/>	<input type="checkbox"/>

<p>E. SAFETY AND CONTROL DEVICES</p> <p>1. Safety limit switches <input checked="" type="checkbox"/> <input type="checkbox"/></p> <p>2. Sound signal <input checked="" type="checkbox"/> <input type="checkbox"/></p> <p>3. Emergency descent system <input checked="" type="checkbox"/> <input type="checkbox"/></p> <p>4. Protection of controls <input checked="" type="checkbox"/> <input type="checkbox"/></p> <p>5. Symbols / control directions <input checked="" type="checkbox"/> <input type="checkbox"/></p> <p>6. Placement of controls <input checked="" type="checkbox"/> <input type="checkbox"/></p> <p>7. Emergency stop <input checked="" type="checkbox"/> <input type="checkbox"/></p>	<p>F. SAFETY FEATURES</p> <p>1. Prevention of unauthorized use <input checked="" type="checkbox"/> <input type="checkbox"/></p> <p>2. Locking device, covers and guards <input checked="" type="checkbox"/> <input type="checkbox"/></p> <p>3. Prevention of lifting <input checked="" type="checkbox"/> <input type="checkbox"/></p> <p>4. Prevention of opening of support <input checked="" type="checkbox"/> <input type="checkbox"/></p> <p>5. Safety distances <input checked="" type="checkbox"/> <input type="checkbox"/></p> <p>8. Control of loading <input checked="" type="checkbox"/> <input type="checkbox"/></p> <p>9. Limiting devices <input checked="" type="checkbox"/> <input type="checkbox"/></p> <p>G. TEST LOADING</p> <p>1. Overload test (150%) 345 kg <input checked="" type="checkbox"/> <input type="checkbox"/></p> <p>2. Functional test (110%) 237 kg <input checked="" type="checkbox"/> <input type="checkbox"/></p>
<p>FAILINGS AND NOTES _____</p>	
<p>Failings have been repaired. Date: _____ Signature: _____</p>	

Dino access platforms are subjected to an overload test and structural and functional inspection for the first time at the factory by the manufacturers authorized inspector. This is a model of a test certificate that is drawn up based on the inspection and delivered with the platform.

Keep this certificate and all other inspection documents with the platform stored in the place reserved for them for a minimum of 5 years.

3. SAFETY

All the essential safety instructions and warnings, relevant to transport, use and maintenance of the lift, are described in this chapter.



DANGER

Failure to observe these instructions and safety regulations may cause a severe injury or even death. Familiarise yourself with all the safety regulations, operating instructions and signs affixed to the machine, and follow them.

Make sure that you understand all the safety instructions and regulations. Also make sure that others operating the machine or working on the work platform are familiar with these instructions.

3.1. SAFETY INSTRUCTIONS

Only specially trained personnel with authorisation in writing, who are well familiarised with the device, and at least 18-years old, are allowed to operate the unit.

Keep the lift free of any dirt, which may impair safe operation, and impede the inspection of the structures.

The device must be serviced and inspected regularly.

Only skilled persons, familiar with the service and repair instructions, are allowed to carry out servicing and repair work.

It is strictly prohibited to use a lift which is out of order.

Never remove or disable any safety devices of the machine.



WARNING

The device must neither be altered without the manufacturer's consent nor be used under conditions, which do not meet the manufacturer's requirements.

The operator must receive instructions and consent from the manufacturer for all such specific work methods or conditions that the manufacturer has not explicitly defined.

TRANSFERS

Observe the maximum allowed gradient when transferring the lift. During transfer in rough terrain, always try to position yourself higher than the machine.

Beware of fixed or moving obstacles in the terrain or near the lift while driving. Make sure that you have a clear view of the driving path.

Do not use the machine for towing.

WORK AREA AND PREPARATIONS BEFORE LIFTING WORK

When working in busy areas, the operating range of the lift must be clearly marked by using either warning lights or fencing.

Also observe the road traffic regulations.

Ensure the unobstructed range of movement before operating the outriggers.

The load-bearing capacity and the gradient of the base must be taken into account when supporting the chassis. Do not use the lift if it is on a lorry, a railway car, a floating vessel or any other potentially unstable platform.

Ensure that the outriggers cannot slide while on a gradient.

Additional support plates of adequate size must be used under the outriggers, when working on soft ground. Only use such additional support plates, on which the metallic outriggers will not slide.

While in the support position, ensure that the wheels are off the ground.

Always ensure the level position of the machine before starting the operation.

Always ensure that the work area is clear of outsiders. Danger of getting squeezed between rotating and fixed structures.

While operating the boom from the control centre on the turning device, beware of getting pressed against the outriggers or other structures that do not turn with the boom.

LIFTING AND WORKING ON THE PLATFORM

Never exceed the maximum number of persons, maximal loading or hand power, allowed for the lift. Never add load onto the platform while in the upper position.

Before operating, always ensure that the safety devices and the emergency descent system are in working order.

Use the safety harness! Fix the safety harness to the fixing points, intended for the purpose.

Note! The platform is fitted with a fixing point for the safety harness of each user. Only one harness per fixing point.

Do not use ladders, steps or other similar equipment on the platform.

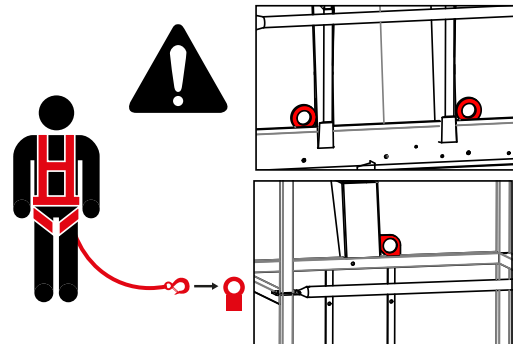

Ensure that the gates are properly closed before starting the operation. If the work platform is equipped with ladder, these must be locked in the upper position.

Never throw or drop any objects from the platform. All the tools must be transported on the inside of the platform. Never leave the tools hanging outside the work platform, supported only by their power cord.

Do not lift the tools, accessories or other material on the railing of the platform or attached to the railing.

The aerial work platform must not be used for lifting.

The work platform must not be used for transferring goods or persons between different floors or working levels. Stepping on or off the platform in motion is prohibited.

When the boom is in its lowest positions, make sure it cannot clash during rotation with structures that do not turn with the boom.

Always make sure, before lowering the platform, that the area under it is clear.

Avoid damaging the platform by lowering it on the ground, or bringing it in contact with any structures.

Never use a lift alone. Make sure that there is always someone on the ground, who can call for help in case of an emergency.

OPERATING CONDITIONS

The weather conditions, such as wind, visibility and rain, must always be taken into account so that these will not adversely affect the safe performance of the lifting operations.



The use of the lift is prohibited, if the temperature drops under -20 °C or the wind speed exceeds 12.5 m/s

Wind speed (m/s)		Conditions on land
0	Calm	Smoke rises vertically
1-3	Light breeze	Smoke moves with the wind and the wind feels on exposed skin. Leaves rustle.
4-7	Gentle breeze	Leaves and small branches of trees are moving. Flag is flying. Wind lifts dust and loose pieces of paper from the ground.
8-13	Strong breeze	Small broad-leaved trees and large branches sway. Wind whistles as it hits houses or other fixed objects. Umbrella is difficult to use.
14-17	Strong	All the trees are swaying. It is difficult. to walk against the wind.

NOTE! The wind speed can be much higher at a higher altitude than on the ground level.

Do not take tools/material of large surface area onto the platform. The increase in wind load may jeopardize the stability of the device.

Beware of the live aerial power lines in the area – observe the minimum safety distances:

Voltage range (phase to phase)	Minimum distance	
	Metres	Feet
0–300 V	Avoid contact	
300 V–50 kV	3	10
50 kV–200 kV	4.5	15
200 kV–350 kV	6	20
350 kV–500 kV	8	25
500 kV–750 kV	11	35
750 kV–1000 kV	14	45

These distances shall apply unless more stringent limits are given in worksite instructions or in local or governmental regulations.

This aerial work platform is NOT insulated, and does not offer protection against contact with electric current. The aerial work platform must not be used for work on electric systems.

3.2. SAFETY-RELATED NOTIFICATIONS

The following safety alert symbols and safety signal words are used in this manual.

Observe all the safety instructions that follow these symbols, in order to avoid dangerous situations and personal injuries.



This is a general safety alert symbol and it is used to alert you about a potential hazard. Observe the additional instructions given in form of text or symbols that follow this symbol.



DANGER

Red DANGER-message warns for an imminent or potential hazardous situation which, if not avoided, may result in death or serious injury.



WARNING

Orange WARNING -message is used in connection with potential risk factors, which if not avoided, under certain conditions, may result in death or serious injury.



CAUTION

Yellow CAUTION -message is used to warn about a hazardous situation which, if not avoided, could result in minor or moderate injury.

NOTICE

Blue notice-message is used to draw your attention to special notifications or instructions that are related to the operation or maintenance. Such messages include, for example, instructions that are related to reliability of the machine or aim to avoid material losses.



Risk of getting crushed
- moving parts



Risk of getting crushed
- moving parts



Risk of getting crushed
- falling objects



Harmful exhaust gas
emissions

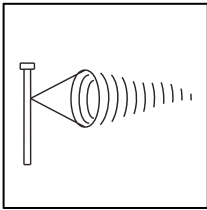

Wind speed



Risk of turning over

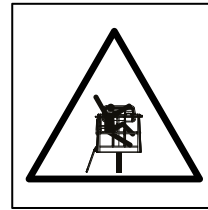

Risk of falling

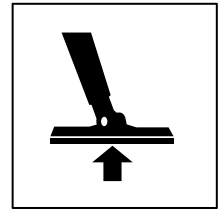

Support force



Smoking prohibited

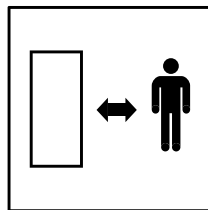

Keep safe distance

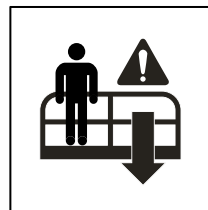

Emergency descent

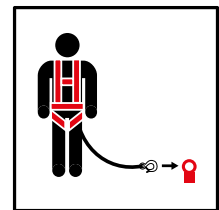

Fixing point for the
falling guard



Open flame prohibited

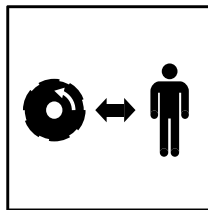

Keep safe distance

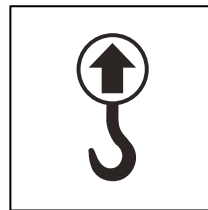

Lifting point

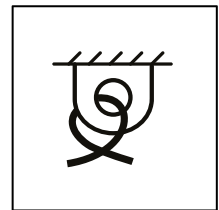

Fixing point



Running the engine
indoors prohibited

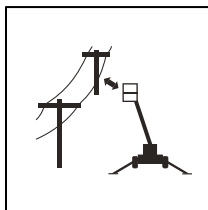

Keep safe distance to
the power lines

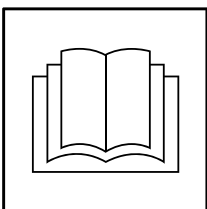

Operating instructions

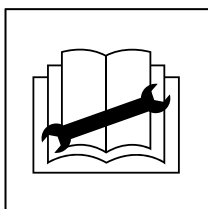

Maintenance
instructions

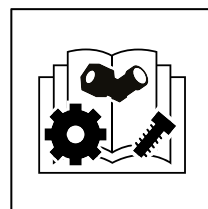

Spare parts catalog

3.3. SAFETY DEVICES

1. Supervision of transport position

Transport position of the boom system is monitored with sensors:

- RK3 = inductive switch for boom and arms down
- RK8 = wire rope sensor for boom extension
- RK1, RK2 = inductive switches for rotation of turning device
- RK32, RK30 = angle sensors for boom angle relative to chassis angle

Driving and operation of the stabilisers is prevented unless the machine is in transport position.

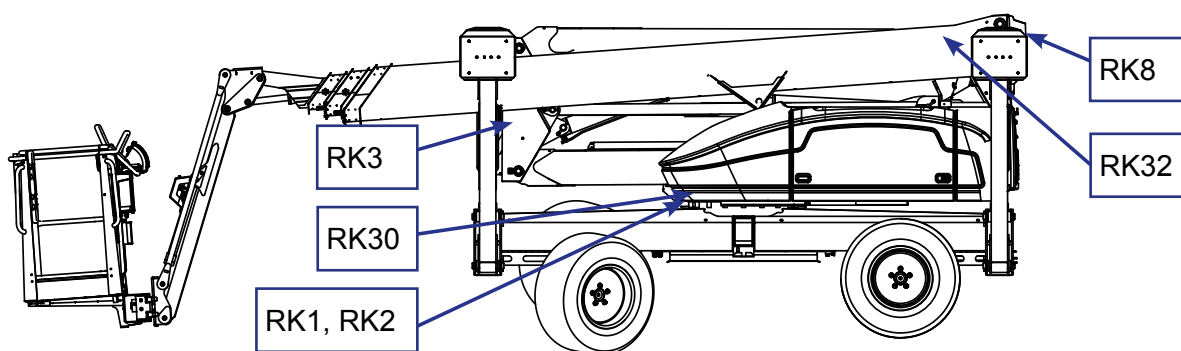

2. Supervision of support position

All the lift's stabilisers must be in support position before the boom is lifted. Make sure that the wheels are off the ground.

The safety limit switches RK11, RK12, RK13 and RK14 are located on the support stabilisers.

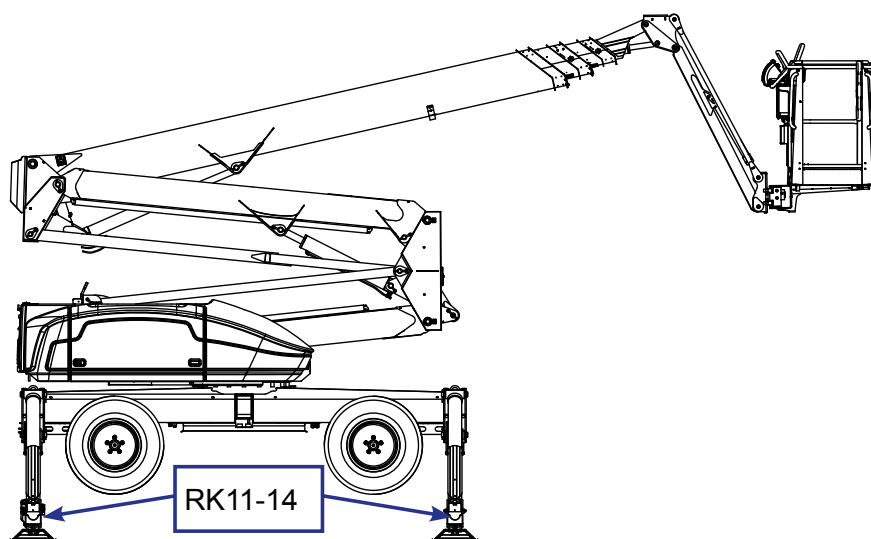

3. Chassis inclination sensor

The inclination sensor RK30 monitors chassis inclination. The sensor is located under the front cover.

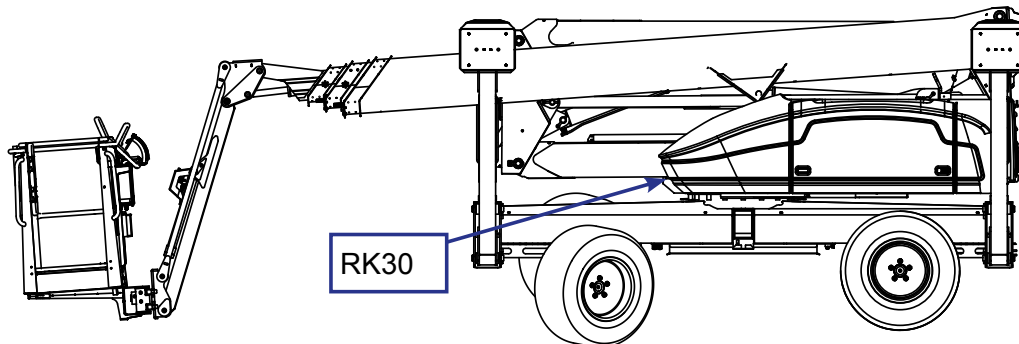

To start the aerial operation, the chassis must be levelled with stabilisers within 1°. Inclination signal lights must be off.

UCB



LCB



During aerial operation, the signal light will start flashing if the chassis inclination exceeds 1°. Exceeding 5° will prevent operation of:

- boom rotation
- main boom up / down (main boom down is prevented until the telescope is fully in)
- articulated arms up
- telescope out

4. Overload control of the boom

The moment sensing system prevents the lift from being overloaded by limiting the outreach of the lift to the side. The allowed outreach depends on the load on the platform.

The loading is monitored with:

- B1-B4 pressure sensors
- RK32 = boom angle sensor
- RK8 = wire rope sensor for boom extension

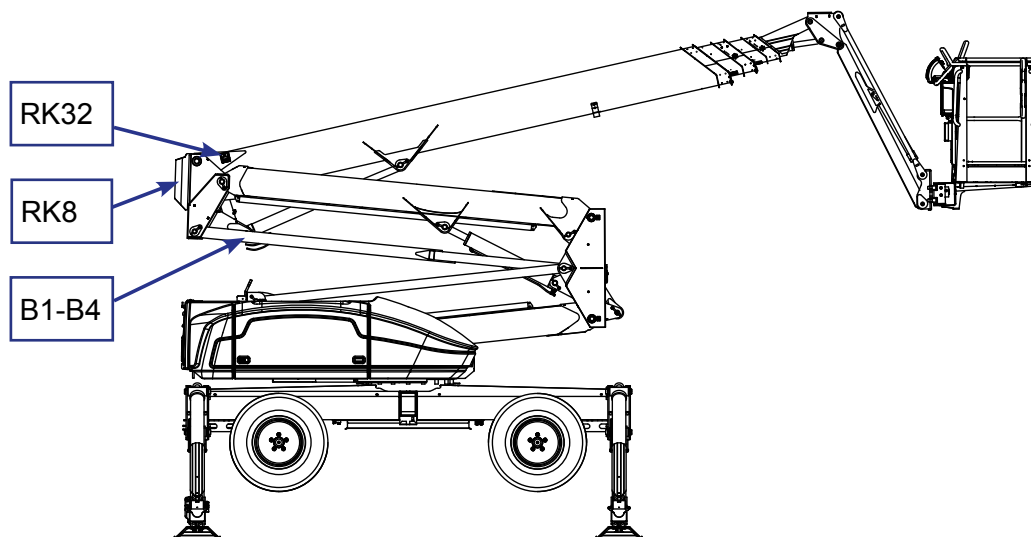

All movements can be operated normally when the platform is within the allowed operating range. If the boom system is overloaded or driven to the outreach limit, the moment sensing system stops the movements that impair the stability of the lift.

Prevented movements:

- telescope extension
- main boom down (main boom down is prevented until the telescope is fully in)
- jib arms up/down
- platform rotation

When the boom is at 90-99% outreach, the signal lights will flash and a sound signal will sound intermittently.

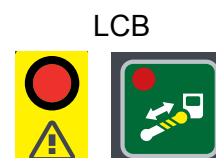

When the boom is at 100% outreach or over, the warning lights are on and sound signal sounds continuously.

In this situation, the lift can be operated in the direction, in which it remains inside the permitted outreach area.

5. Supervision of the telescope wire ropes

The telescopic boom has mechanical indicators that indicate possible failure of the wire ropes.

Check the indicators with the machine in transport position, telescopic boom fully retracted.

On the rear end of the boom, all four indicators must be aligned with the green areas marked with the decals.

If the indicators are not aligned, visible, or not at level with the cover, wires may be damaged.

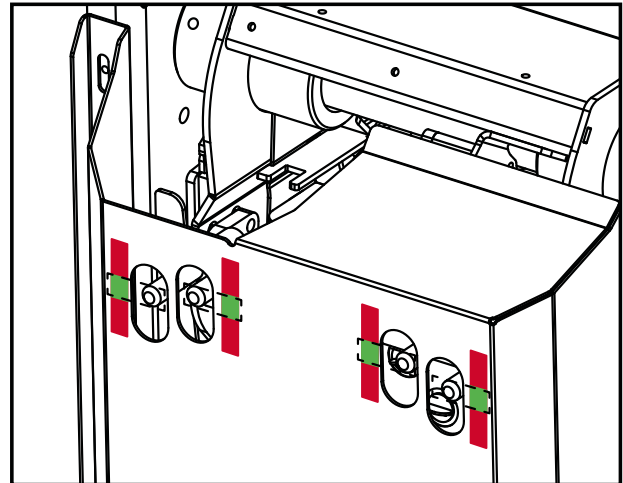

On the front end, all four cylindrical sleeves must be pressed against the end-plate of the boom. The spring should not be visible from under the sleeve.

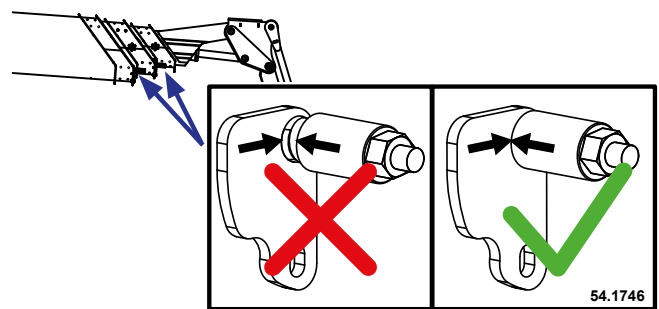

If the indicators show that there may be a problem with the wires, do not operate the boom system.

6. Safety devices for hose rupture

All the load-bearing cylinders are equipped with valves for rupture or leak in the hydraulic system, which prevent the load from falling.

Stabiliser cylinders	Lock valves	2 directions
Lifting cylinder of the boom	Load regulation valve	1 direction
Lifting cylinder of the articulated arms	Load regulation valve	1 direction
Telescope cylinder	Load regulation valves	2 directions
Levelling system (slave cylinder)	Load regulation valve	1 directions
Jib cylinder	Load regulation valve	1 direction

7. Platform inclination control

The platform is levelled hydraulically with a master-slave system. The master cylinder moves with the boom and controls the slave cylinder that inclines the work platform.

The levelling system comprises the following parts:

1. Master cylinder
2. Slave cylinder
3. Load regulation valve on slave cylinder
4. Double load regulation valve
5. Electric directional valve

The platform keeps its level position only if the valves in the system are tight. Any leaks or air in the levelling system causes inaccuracy during levelling of the platform.

8. Emergency stop buttons

Pressing down the emergency stop button shuts down the control system, stops all the movements immediately and turns off the power unit. A button can be found at each control station.

When the machine is in emergency stop mode, red lights flash on all control buttons and the indicator light in the LCB center emergency stop button goes out.

The emergency stop button locks in the lower position, and it must be released before starting the power unit.

NOTICE

If the unit does not start, make sure that the emergency stop button is not in the lower position at any of the control stations.

9. Emergency descent system

As a precaution against possible failure in the power supply, the lift is equipped with a battery operated emergency descent system.



The diesel engine stops once the emergency descent system is started.

The emergency descent system can be used from either control station regardless of the control station selection. Starting the emergency descent system activates the control station from where it's used and deactivates the other control station.

The emergency descent system allows the operation of all other movements, except telescope extension and articulated arms up. All normal safety devices remain operational during emergency system operation.

EMERGENCY DESCENT SYSTEM IN EMERGENCY STOP MODE

If the emergency stop button has been pressed, the emergency descent system can only be operated from the ground level. Emergency stop disables the normal control system and safety devices and only the manually controlled system remains operational.



DANGER

Risk of turning over the lift and serious structural damage! Manual operation of the valves overrides critical safety devices. For this reason, the operating lever has been sealed. The system should only be used to rescue a trapped operator in an emergency in case normal control system can not be operated.

4. BASIC STRUCTURE AND FUNCTIONS

The denominations of the machine's essential parts and concepts, which are used later in these instructions, are described on this page.

4.1. STRUCTURE

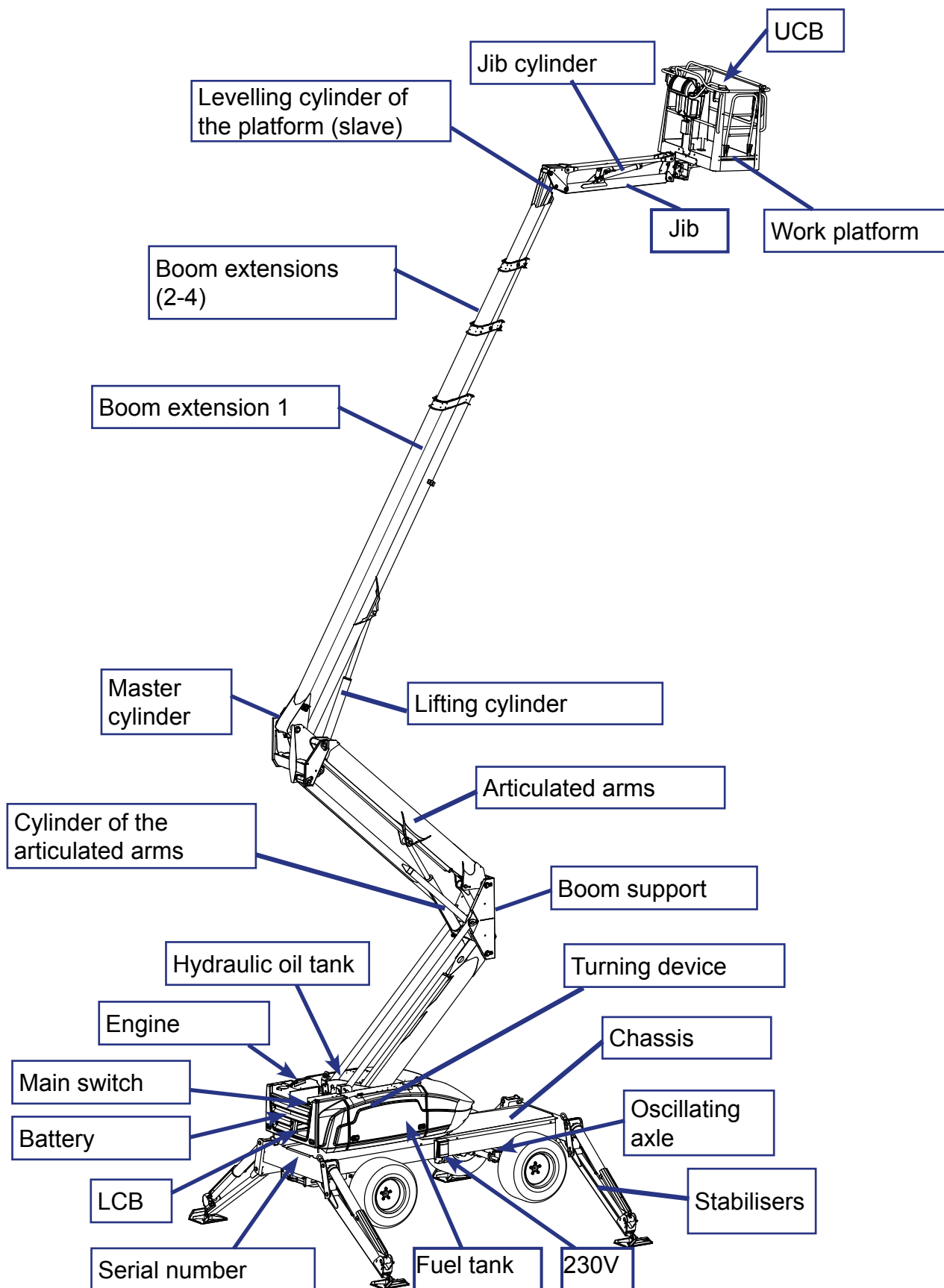

4.2. BASIC FUNCTIONS

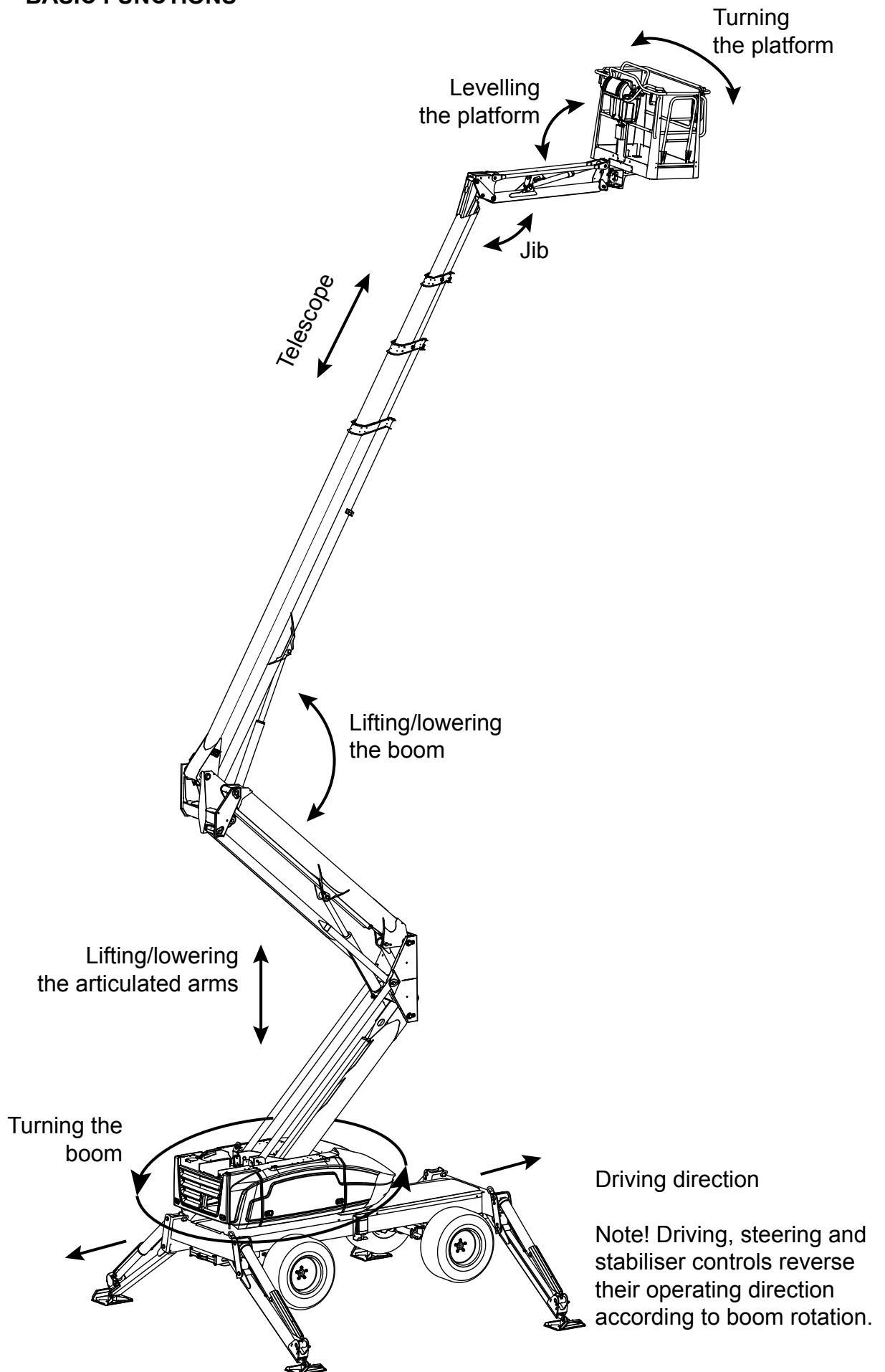























4.3. OPERATING CONTROLS









Colours used in control panels	
Green	Boom system
Blue	Stabilisers
Red	Driving
Yellow	Emergency operation / symbol contrast colour
Grey / white	General

Yellow symbol contrast colour is used in the symbols to highlight the movement that is activated with the control.







General

	LCB controls active		UCB controls active		Retraction of telescope / emergency use
	UCB controls active		Emergency descent system active		Safety related message / operation
	Engine stop		Engine start		Fast speed range
	Glowing		Slow speed range		Direction selection up
	Differential lock		Direction selection down		Enter
	Generator		Activation		Off
	Compressor				
	Driving lights				
	Sound signal				
	Limited operating mode for shortened transport position.				

Stabiliser operation and driving

	Direction selection for stabiliser operation		4-wheel steering
	Selection of stabiliser / manual operation		2-wheel steering
	Automatic levelling with stabilisers		Crab steering
	Driving		Steering - right
			Steering - left

Boom operations

	Turning device rotation		Boom
	Articulated arms		Telescope
	Jib arms		Turning of platform
	Platform inclination		

4.3.1. Platform panel UCB



1	Emergency stop	RJ	Boom operation mode
2	Display		Boom up/down
LJ	Left joystick		Boom rotation right/left
	Manual stabiliser operation mode:		Driving mode
	Selection of stabiliser		Drive forwards/backwards
	Boom operation mode:	RJa	Steering left
	Articulated arms up/down	RJb	Steering right
	Telescope in/out		
MJ	Automatic stabiliser operation mode:		
	Automatic levelling up/down		
	Boom operation mode:		
	Jib arms up/down		
	Turning of platform right/left		

4.3.2. Display

The basic display view after start-up shows the status of the stabilisers and the inclination of the chassis.

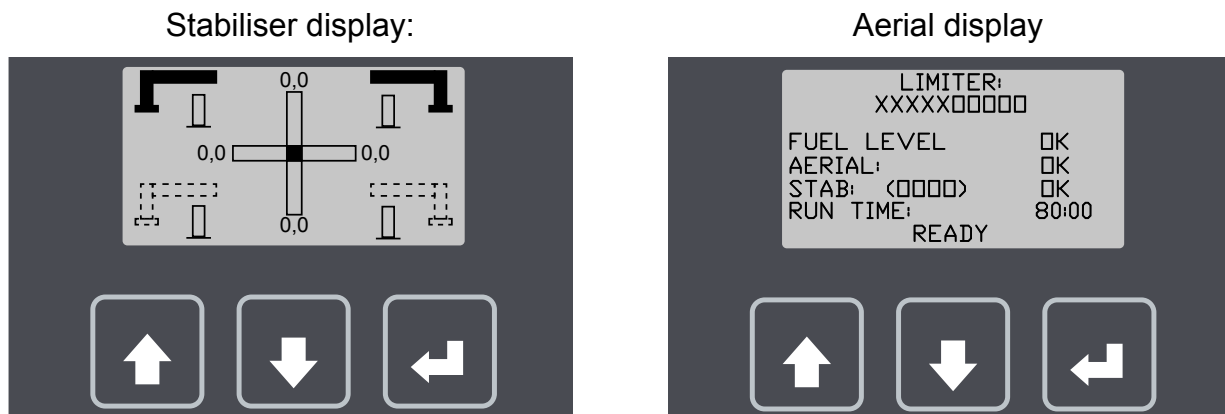

Once the boom system is driven away from transport position, the display will automatically switch to the Aerial display.

Aerial display

Information	Values	Description
Limitier	XXXXXX□□□□□□	“X” bar shows the platform load / position as a percentage from the maximum. □□□□□□□□□□□□ = Boom at minimum outreach / maximum load XXXXXXXXXXXXX = Boom at maximum outreach / maximum load
FUEL LEVEL	OK / LOW	LOW = Fuel level is down to 19 liters
AERIAL	ON / OFF	Aerial operation allowed / prevented
STAB	ON / OFF	Operation of stabilizers allowed / prevented
	XXX□	□ = Stabilizer up X = Stabilizer down
OPER. TIME	HH:MM	Operating time = Engine time + El. motor time (hours:minutes)

Pop-up messages on displays:

EMERGENCY STOP	Emergency stop button has been pressed.
ENGINE TEMP	Water temperature over the temperature limit. Engine is stopped.
ENGINE OIL PRESS	Engine oil pressure is too low. Engine is stopped.
ERROR CODE:	In case of machine failure managed by fault codes.
FUEL LOW	Fuel level is down to 19 liters.
MAX TILTING	In case the chassis inclination exceeds the limit value during driving.
OUTREACH LIMIT	Platform is on the outreach limit.
CAGE LOAD LIMIT	Platform load is at maximum limit.
PRESS PEDAL	Activation pedal needs to be pressed to allow any operations.
READY	system is ready for operation.
RELEASE ALL	Controls were actuated before activation pedal was pressed. All controls need to be released before pressing the activation pedal.
SAFE GUARD STOP	If safe guard has been triggered (option).
STABILITY LIMIT	Chassis stability condition is lost.
START please wait	While engine is starting.

Press enter to move to selection of other display views.
 Alternate display views can be browsed with arrow keys.

Notice! Information shown on the displays varies depending on machine configuration!

Operating time display

Information	Values	Description
TOTAL TIME	HH:MM	Total operating time (hours:minutes)
PARTIAL TIME	HH:MM	Shows the operating time since reset (hours:minutes)
ENGINE TIME	HH:MM	Shows the time the machine has been operated with the internal combustion engine (hours:minutes)
EL.MOT. TIME	HH:MM	Shows the time the machine has been operated with the electric motor (hours:minutes)

Engine display

Information	Values	Description
FUEL LEVEL	OK / LOW	LOW = Fuel level is down to 19 liters
WATER TEMP.	OK / HIGH	Water temperature is below / over the maximum limit
OIL PRESS.	OK / LOW	Oil pressure is below / over the minimum limit
RPM ACTUAL:	RPM	Actual RPM value of the engine
STATUS:	STARTING / RUNNING / OFF	Status of the engine

Sensor display 1

Information	Values	Description
LMI	%	Working envelope pressure limit percentage value
LEN	%	Working envelope length limit percentage value
P	bar	Actual differential pressure on lifting cylinder
A	°	Actual main boom angle
L	mm	Actual length of telescopic boom
W	kg	Actual load on platform
STAB	ON/OFF	Operation of stabilisers allowed / prevented
AERIAL	ON/OFF	Operation of boom system allowed / prevented
DRIVE	ON/OFF	Driving allowed / prevented

Sensor display 2

Sensor	Values	Description
S1	ON / OFF	Sensor 1 for turning of the boom. The value must be different from value of S2 for stabiliser operation and driving.
S2	ON / OFF	Sensor 2 for turning of the boom. The value must be different from value of S1 for stabiliser operation and driving.
RK3	ON / OFF	Inductive switch for boom transport position
RK6	ON / OFF	Inductive switch for boom lifting sector
RK8	ON / OFF	Inductive switch for telescope end position
RK18	ON / OFF	Inductive switch for telescope length
PL1	bar	Sensor 1 pressure on lifting cylinder, piston side
PL2	bar	Sensor 2 pressure on lifting cylinder, piston side
PH1	bar	Sensor 1 pressure on lifting cylinder, rod side
PH2	bar	Sensor 2 pressure on lifting cylinder, rod side
A1	°	Sensor 1 for boom angle
A2	°	Sensor 2 for boom angle
L1	mm	Length of telescope, sensor 1
L2	mm	Length of telescope, sensor 2

Movement display

Control	Values	Description
R.CW	ON/OFF	Boom rotation clockwise
R.CCW	ON/OFF	Boom rotation counter-clockwise
S.UP	ON/OFF	Articulated arms up
S.DW	ON/OFF	Articulated arms down
B.UP	ON/OFF	Boom up
B.DW	ON/OFF	Boom down
B.IN	ON/OFF	Telescopic boom in
B.OUT	ON/OFF	Telescopic boom out
J.UP	ON/OFF	Jib arms up
J.DW	ON/OFF	Jib arms down
C.CW	ON/OFF	Platform rotation clockwise
C.CCW	ON/OFF	Platform rotation counter-clockwise

4.3.3. Chassis control panel LCB

1	Selector key switch	2	Emergency stop with indicator light	
	OFF		3	Warning light
	LCB controls active		4	Activation
	UCB controls active			
	Limited operating mode for shortened transport / storage configuration.			

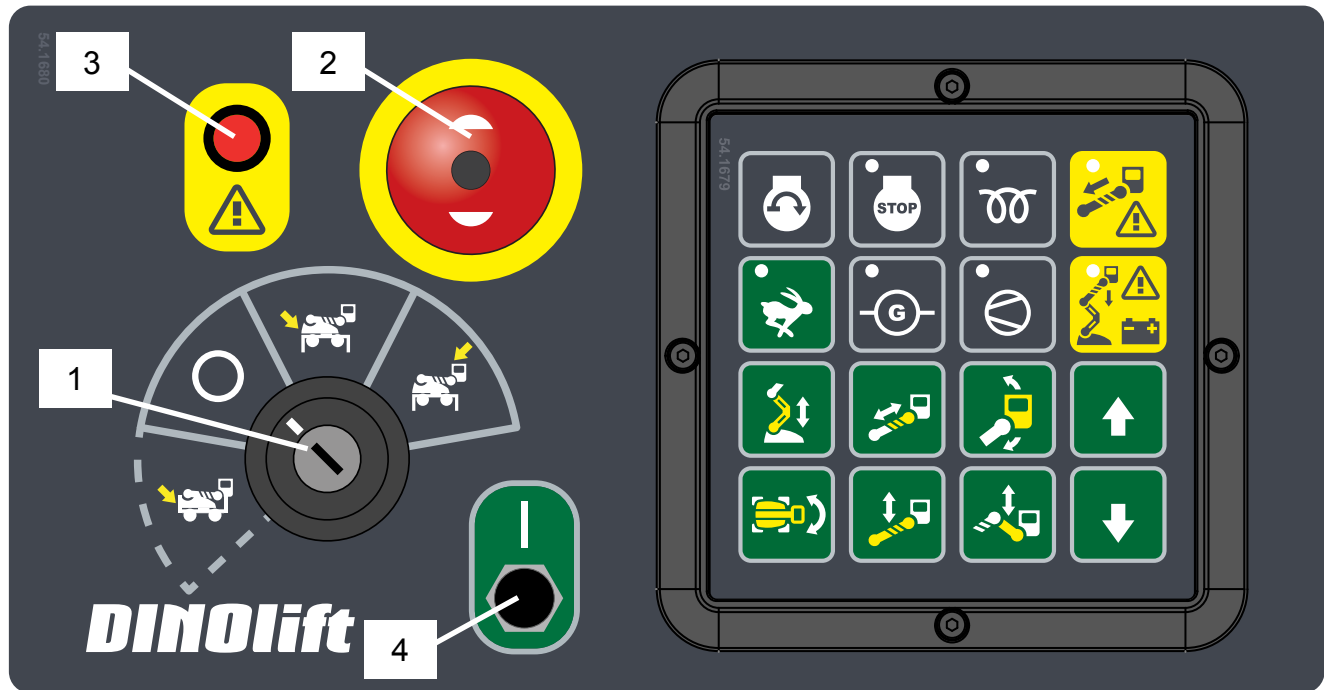

5. OPERATION

5.1. START-UP

NOTICE

All the regular servicing measures must be carried out before using the lift.

The operator must do a worksite inspection and daily maintenance:

- at the beginning of each workday
- before operating the lift at a new worksite
- when the operator changes in the middle of a workday

5.1.1. Worksite inspection

1. General information

- Is the lift suited for the intended job?
- Is the performance of the lift sufficient for the job? (reach, loadability etc.)
- Is the lighting on the worksite sufficient?
- Is the position of the lift safe?
- Is the terrain suitable for using the lift (evenness and load-bearing capacity)?

Soil material	Density	Max. ground pressure kg/cm ²
Gravel	High density	6
	Medium density	4
	Loose	2
Sand	High density	5
	Medium density	3
	Loose	1.5
Fine sand	High density	4
	Medium density	2
	Loose	1
Sand/ mud	High density (very hard to work)	1.00
	Medium density (hard to work)	0.50
	Loose (easily worked)	0.25



DANGER

Risk of overturning! Do not use on soft or unstable ground.

2. Documents

- Are the Operation and Service Instructions for this lift present?
- Are inspections and servicing carried out in accordance with the instructions and have the defects affecting the safety been checked as repaired?
(Inspection protocols)

3. Operator

- Is the operator old enough?
- Has the operator received the required training?
- Is the operator in a suitable condition to operate the machine? The operator must not be under the influence of alcohol or drugs or be otherwise in a state of reduced physical and mental control.

4. Special issues on the worksite

- Are there any additional regulations relevant to the worksite or the work?
- Does the worksite have special hazards (bridge cranes, drop-offs, ATEX-areas, enclosed spaces etc.) to avoid during operation?
- Is there a need for special marking or fencing of the work area to keep personnel from walking under a raised boom and platform?

5. Condition of the machine

- Perform all the daily maintenance tasks according to instructions
- Never use a malfunctioning machine

5.2. INSTRUCTIONS FOR WORKING

COMBUSTION ENGINE

Starting the combustion engine

1. Select the control position UCB or LCB with the key switch.
2. Activate control system with activation pedal (UCB) or activation button (LCB)
3. Press the “glowing” button, if necessary.
 - The red signal-light for glowing illuminates.
 - The glowing time is automatically set.

The signal light for glowing will remain illuminated until glowing of the engine is completed. As soon as the light is switched off, the engine is ready to start
4. Start the engine by pressing the engine start button.

The engine has three different rpm settings. Revolutions increase and decrease automatically during operation.



Switching off the engine

1. Wait until the engine speed has dropped to idling speed.
2. Switch off the engine by pressing the engine stop button



The engine is stopped automatically, if the water temperature is too high or oil pressure is too low. This is indicated by a red flashing light on the engine stop button.

ELECTRIC MOTOR

Connect the plug to the power supply.

Starting the electric motor from the platform.

1. Turn the key switch to position UCB.
2. Activate control system with activation pedal.
3. The electric motor starts automatically once any of the movements is activated.

Starting the electric motor from the chassis control panel.

1. Turn the switch key to position LCB.
2. Activate control system with activation button (LCB)
3. The electric motor starts automatically once any of the movements is activated.

Switching off the motor

The electric motor is automatically switched off in 3 seconds after the movement ends.

NOTICE

Operation powered by the electric motor is not possible until the combustion engine is switched off.

If you wish to use the combustion engine after the electric motor was used, start the combustion engine in the normal way (the power supply plug needs not be disconnected).

5.2.1. Driving

The lift is driven from UCB centre. Notice, that the electric motor can not be used while driving.

 <b style="font-size: 1.2em;">DANGER	<p>Check the terrain before driving! Do not drive in dangerous conditions. Risk of overturning!</p> <p>The inclination must not exceed 25° while driving!</p> <p>Be careful that the platform does not hit the ground while driving on uneven terrain.</p>
---	---

Check that the boom rests on the support, boom rotation is in center position and the stabilisers are in the upper position! Jib arms, platform rotation and platform levelling can be operated during transport driving.

1. Attach the safety harness to the anchor point on the platform.



2. Activate controls with activation pedal.

None of the movements may be activated. The pedal must be kept active throughout the operation.

If the pedal is held down for more than 10 seconds, and no movement is activated during this time, the pedal must be released and re-activated



3. Select the driving speed range. The selected speed range is shown with the signal lights on the buttons.

NOTICE! The machine must be stationary while switching the speed range.

Fast driving speed range



Slow driving speed range



 <b style="font-size: 1.2em;">CAUTION	<p>The maximum speed with fast driving speed range selection is over 10km/h. Do not use in constricted spaces or in rough terrain!</p>
--	--

4. Select the steering mode. 3 different steering modes can be selected.

The selected steering mode is shown with the signal lights on the buttons.

2-wheel steering.

Only the foremost wheels turn.



4-wheel steering. Only available in slow driving speed range.

The front and rear wheels turn in opposite directions.



Crab steering. Only available in slow driving speed range.

All wheels turn in the same direction.



As different steering modes are engaged, the wheels on the rear axle will assume the default position according to the selected steering mode once the steering or drive controls are activated.

5. Activate the differential lock for better traction control if there is a risk of one or more wheels slipping in rough terrain.



NOTICE! The machine must be stationary while engaging or disengaging the lock.

NOTICE! Tight turns with the differential lock on solid ground will require more power from the engine and can generate a lot of heat in hydraulic system. Use the differential lock only in rough terrain when there is a risk of one or more wheels slipping!



6. Activate the desired movement using the right control lever



7. Steer the machine with pressing the switches at the end of the control lever.

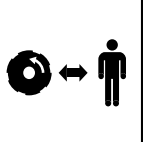

NOTICE! The driving and turning directions will change if the turning device is reversed with respect to the chassis.

 CAUTION	<p>The rotating wheels cause a crushing hazard! Be aware of blind spots when driving or operating. Check that the area is clear from outsiders.</p> <div style="display: flex; justify-content: space-around;">   </div>
--	---

5.2.2. Support position

The stabilizers can only be operated, while the articulated arms and boom are on the support and the telescopic boom is fully retracted.

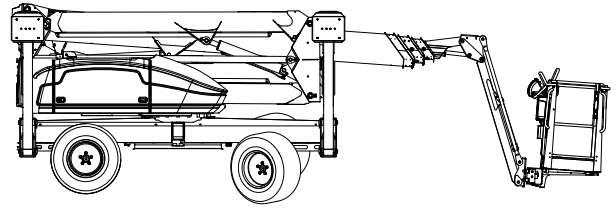

1. Attach the safety harness to the anchor point on the platform.
2. Activate controls with activation pedal. None of the movements may be activated. The pedal must be kept active throughout the operation.

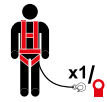

If the pedal is held down for more than 10 seconds, and no movement is activated during this time the pedal must be released and re-activated

To use the stabilizers with automatic levelling function:

1. Select automatic levelling mode with selection button. A signal light on the button will indicate that the function is active. The function will deactivate:
 - when the button is pressed again,
 - a different stabiliser function is selected or
 - no movement has been driven for 5 seconds.
2. Select the direction of movement by turning the middle joystick. Keep the levelling operation activated until the movement stops.

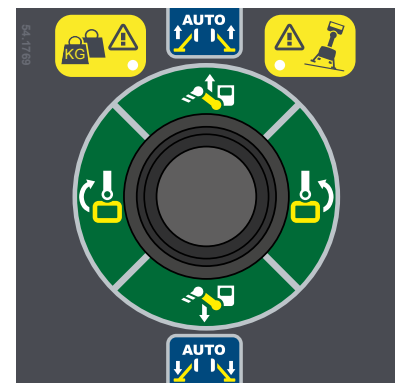

3. Verify the level position of the lift. The electronic display with columns indicates when the horizontal position is reached.

The operation of the display is the following.

- The columns indicate that the chassis lies higher on that side than on the opposite side. The numbers indicate the inclination angle.
 - When the signal is on only in the centre, the chassis is at level position.
 - Black stabiliser markings on the display indicate that the stabiliser is pressed to the ground.
4. Readjust manually, as necessary.

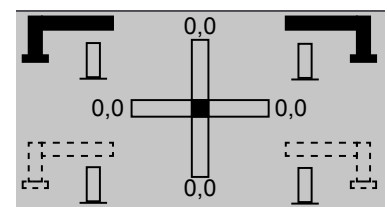

To adjust the stabilisers individually:

5. Select direction of movement with selection buttons. A signal light on the button will indicate that the function is active. The function will deactivate:
- when the button is pressed again,
 - a different stabiliser function is selected or
 - no movement has been driven for 5 seconds.



6. Select the stabiliser you want to operate by turning the left joystick. Each stabiliser can be used separately or they can be used two at a time.

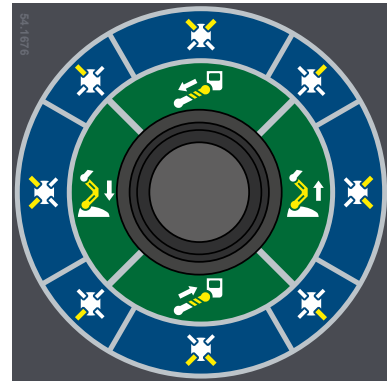

NOTE! Stabiliser controls reverse their operating direction if the turning device is reversed with respect to the chassis.

While using stabilisers, ensure

- the unobstructed operating range.
- the wheels are off the ground and the footplates are lower than the wheels
- the stabilisers are firmly supported and cannot slide on a gradient

When raising the stabilisers make sure they are fully retracted before driving. Avoid damage caused by contact to the ground.



DANGER

Risk of turning over the lift! Using the lift is prohibited unless it is properly supported. Observe the effect of ice, possible rain and inclination of the surface on the support force (the stabilisers must not slip on the surface). As required, test the stability by turning the boom around loaded but the telescope fully retracted. If you notice that the chassis inclines during the test, you must not continue the use.

Before operating the lift, check that:

- the chassis is level
- that the wheels are off the ground
- that all the stabilisers are well supported on the ground



WARNING

Carry out all daily maintenance routines and inspections in accordance with the maintenance instructions before operating the lift. **Failure to check the safety devices may cause serious injury or make the consequences of an accident worse.**

All faults in safety devices must be repaired before operating the lift

5.2.3. Operating the boom from the platform

The operation of the boom is only possible if the stabilisers are firmly supported on the ground and the chassis is levelled.

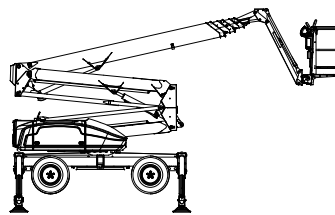

DANGER

Risk of falling! Wear a safety harness while on the platform, and fix it to the point marked for them. Check that the gate of the platform remains closed during operation.

1. Attach the safety harness to the anchor point on the platform.



2. **Activate controls with activation pedal.**

None of the movements may be activated. The pedal must be kept active throughout the operation.

If the pedal is held down for more than 10 seconds, and no movement is activated during this time the pedal must be released and re-activated



3. **Activate movements using control levers.** The engine revolutions increase or the electric motor starts.

The boom movements operate as described in the following table

Lever	Movement	Movement speed	Symbol	
LJ	↑ / ↓	Telescope in / out	Stepless adjustment	
LJ	← / →	Articulated arms down / up	Stepless adjustment	
MJ	↑ / ↓	Jib arms up / down	Stepless adjustment	
MJ	← / →	Turning the platform clockwise / counter-clockwise	Stepless adjustment	
RJ	↑ / ↓	Boom up / down	Stepless adjustment	
RJ	← / →	Turning device rotation clockwise / counter-clockwise	Stepless adjustment	
		Platform levelling	Constant speed	

The movements can be used simultaneously. If several control levers are operated simultaneously, the speed of individual movements decreases.



DANGER

Risk of overturning! Do not overload the machine.

It is strictly prohibited to take additional load in the upper position.

Do not exceed the allowed manual force (400N), or load the platform more than allowed.

Never add load onto the platform, while the red signal light for overloading is flashing. The overload control device prevents hazardous movements if the platform is overloaded or out of outreach area.

Do not operate the boom if the inclination of the unit exceeds the maximum allowed inclination.



When moving the platform, remember the following

- be careful of the high voltage power lines
- do not touch open electric wires
- do not drop or throw objects from the platform
- do not damage the lift
- do not damage other devices



CAUTION

Crushing hazard! Keep a safe distance to the moving parts of the lift and to buildings and other obstructions around the lift. Hands and legs must be kept inside the work platform while the platform is moving. Beware of any obstacles above the platform.

Observe when lifting the platform

The operating range of the platform depends on the load (see Technical Data) and is monitored by the moment sensing system. The inspection and adjustment of the system may only be carried out by an authorized serviceman.

In case of exceeding the allowed operating range for carried load, the overload monitoring system prevents all hazardous movements and gives a visual and audible warning signal.

5. Working in the same position for a long time

- It is not necessary to let the engine run if the platform is kept for a longer period of time in the same position
- When the weather is cold, it is recommended to let the engine run to keep the hydraulic oil warm
- It is recommended to also leave the combustion engine running between the operations, to ensure the battery remains well charged
- Check the stability and condition of the base regularly during the operation, taking into account the weather and ground conditions

6. Lowering the platform to transport position

Before lowering the boom onto the transport support, retract the telescope completely and turn the platform perpendicular to the boom.

7. When leaving the lift

- switch off the power unit
- prevent unauthorized use of the lift by removing the ignition key

5.2.4. Operating the boom from the chassis panel

The chassis panel is a secondary control station and only boom operations can be controlled at UCB controls. All drive functions and stabiliser movements are controlled from the platform control station.

1. Select the control position LCB with the key switch.



2. Activate control station with activation button



3. Select the fast movement speed if necessary. Light on the upper left corner of the button is on while the fast movement speed is selected.



4. Select direction of movement with selection buttons. The button must be kept active throughout the operation.



5. Select the desired movement. The selected movement moves at constant speed. The button must be kept active throughout the operation.



5.2.5. Measures to be taken at the end of the working day

At the end of a workday:

1. Retract the telescope completely.
2. Check that the platform is perpendicular to the boom.
3. Lower the boom onto the support.
The limit switch on the transport support prevents operation of the stabilisers if the platform is not down
4. Close the cover on the platform control panel.
5. Turn the key switch to position "0".
6. Turn the main switch off
7. Make sure that the covers are locked.

5.2.6. Special instructions for winter use

The lowest allowed operating temperature of the lift is -20 °C

In cold conditions do the following special actions in addition to normal start-up procedure.

1. if the temperature is below zero, let the power unit run for a few minutes before starting the movements
2. start with a few movements to warm-up oil in the cylinders and to ensure proper operation of the valves
3. check that the limit switches and the emergency descent devices are operational and clean (from dirt, snow, ice, etc.)
4. protect the control panel and the platform from snow and ice whenever they are not in use



Always keep the lift free from dirt, snow, ice, salt, etc. Accumulation of grit may cause malfunctions, paint damage, corrosion and excessive wear of components and structures.

5.3. IN CASE OF EMERGENCY

5.3.1. When at risk of losing stability

Reduced stability can be caused by a fault in the lift, the wind or other lateral force, collapse of the standing base or negligence in providing sufficient support. In most cases one sign of reduced stability is the inclination of the lift.



1. If there is time, try to find out the reason for the reduced stability and the direction of its effect. Warn other people on the worksite using the alarm signal.

2. If possible, reduce the load from the platform in a safe manner.



3. Reduce the outreach to the side by retracting the telescopic boom. Avoid abrupt movements.



4. Turn the boom away from the danger zone to the direction where stability is normal.



5. Lower the boom.

If the stability has been lost as a result of a fault in the lift, repair such a fault immediately.



Do not use the lift until the fault has been repaired and the condition of the lift has been verified.

5.3.2. In case the power supply is interrupted (power unit / combustion engine)

As a precaution against possible power failure, the lift is equipped with a battery operated emergency descent system. The emergency descent can be operated from each control centre.



1. Start the emergency descent system with the pushbutton. When the emergency descent button is pressed, the battery operated emergency descent unit starts. The emergency descent system is operational only when the pushbutton is being pressed.



2. Reduce the outreach to the side by retracting the telescopic boom. Avoid abrupt movements.



3. Lower the boom.



4. Lower the articulated arms

5. Establish the reason for interruption of the energy supply.

The emergency descent system can also be used for raising the stabilisers to the transport position:

- Start the emergency descent unit from the UCB control panel
- Lift the stabilisers

Setup of the system

- battery 12V 68Ah
- hydraulic unit 12 VDC
- (automatic charger of the battery 12VDC 10A, on the model powered by electric motor)

The hydraulic unit comprises:

- pressure relief valve, set value 21 MPa (210 bar)
- check valve
- direct current motor
- hydraulic pump



Always check the condition of the emergency descent system before starting to use the lift.

5.3.3. In case the emergency descent battery is empty

In case of a malfunction where even the emergency descent system does not operate, try to warn other personnel present on the site so that they can help or call for more help.

When help arrives, they should try to:

- restore the power supply required for normal operation
- make the emergency descent system operational by, for example, changing the battery so that the person on the platform can be lowered safely.
- resume normal operation by other means



Do not use the lift until the fault is repaired!

5.3.4. In case of malfunctioning control system

In case of problems with the moment sensing system or control valve:



1. Try to find out the reason for the problem and try restarting the machine.
2. Reduce the outreach to the side by retracting the telescopic boom fully using the emergency retraction system. Avoid abrupt movements.
3. If possible, lower the boom with normal operating movements.

In case of complete control system failure or in case the machine must be driven down in the emergency stop mode, the operation must be performed manually from the ground level.

1. Open the side cover on the left side
2. Open the selection valve by turning the finger screw at the end of the valve
3. Press the green emergency descend button to turn on the emergency pump
4. Detach manual control lever from the sealed storage position
5. Operate the movements by manually controlling the valve spools with the lever.

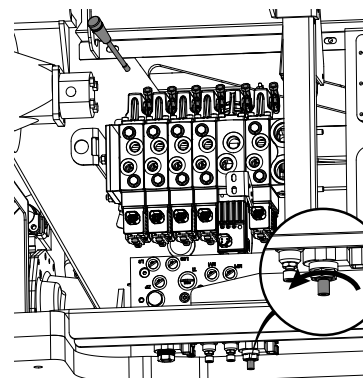

Retract the telescope.

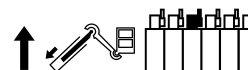

Lower the articulated arms



Lower the boom

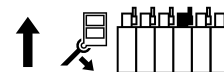

Turn the boom



Operate the movements in the sequence described above. If a different sequence must be followed to avoid collision with surrounding structures, pay special attention to safety of movements and stability of the machine!

**DANGER**

Risk of turning over the lift and serious structural damage! Manual operation of the valves overrides critical safety devices and the emergency stop system.
The system should only be used to rescue a trapped operator in an emergency in case normal control system is not operational.

After manual operation

- restore the machine to normal operating condition
- inspect all load bearing structures
- check that all controls, movements and safety functions work normally
- put back and re-seal the manual control lever to its storage position

5.4. LONG-TERM STORAGE

Clean the machine carefully. Lubricate and apply protective grease to it before putting it into storage for a longer period of time. Repeat the cleaning and lubrication procedures before putting the lift back in operation.

The periodic inspections must be executed following the steps described in the instructions.

5.5. INSTRUCTIONS FOR TRANSPORT

The lift must be in the transport position when lifting, towing or tying it down for transport. All lugs for lifting and tying down are marked in the machine.

Remove all loose material from the top of the frame structures and the work platform. All protective covers must be closed and locked. Turn the key switch to "O", disconnect the lift from external power supply and turn the main power OFF.

5.5.1. Tying down

Tie down the lift at four (4) tying down points on the chassis. Also tie down the boom to stabilize the turning device and jib arms.



CAUTION

Risk of falling! Tie down the lift to the vehicle for the transport. The chassis of the lift is fitted with specific, marked lugs for tying. To avoid structural damage, use only the marked tying points.

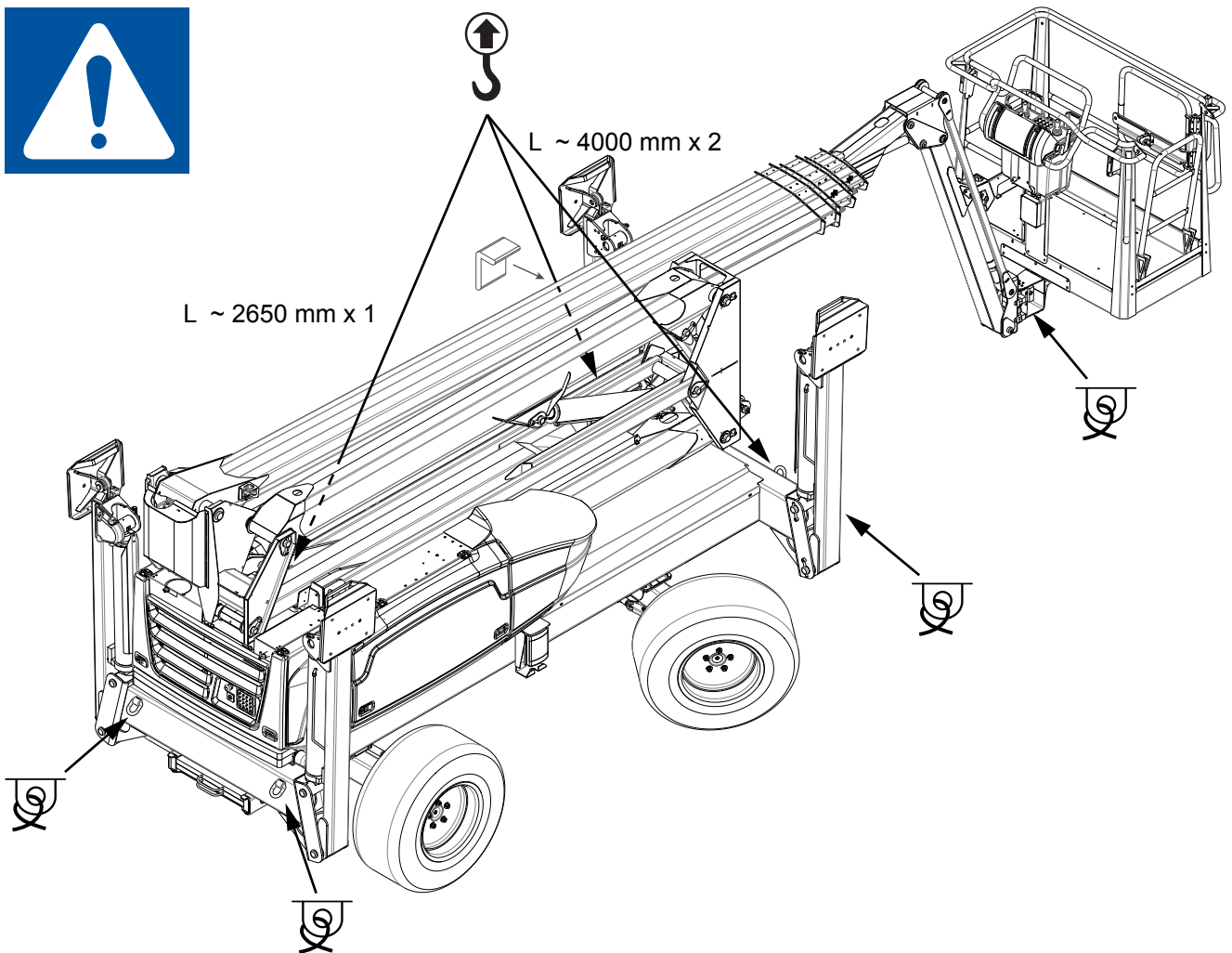

5.5.2. Lifting

The device can be lifted from the lugs shown in the picture. Lugs are placed symmetrically on both sides of the device. Lifting lugs are also marked in the machine with instructional labels.

During lifting the platform must be in transport position. Remove all loose material and other excess load from the platform before lifting.

Use a suitable crane and lifting accessories. Make sure that the crane and other lifting equipment are strong enough for the weight of the device. Check the weight from the technical specifications.



**Be careful not to damage the device during the lifting!
Use protective padding between chains and boom structures to prevent scraping!**

5.5.3. Shortened transport position

Transport length of the machine can be reduced by turning the jib arms and the platform underneath the telescopic boom. While the machine is in the shortened transport position, all other movements, including driving, are disabled.

1. Drive the machine to the desired location.
2. Change the key switch to limited operating mode for shortened transport position.
3. Restart the engine.
4. Lift the boom. The boom will stop at a specified angle that allows for the shortened transport position.
5. Drive the jib arms down to lowest position.
6. Use the levelling function to drive the platform under the boom.
NOTICE! Do not use the jib controls while the platform is turned under the boom. The negative load may cause sudden and unwanted movements.
7. Drive the boom down until the platform's edge comes in contact with the surface of the transport platform
8. Turn off the power. Turn the mains switch to position '0'



After transport:

9. Turn on the mains switch and activate the control system with activation button
10. Turn the key switch to limited operating mode for shortened transport position.
11. Start the engine
12. Lift the boom. The boom will stop at a specified angle that allows for the shortened transport position.
13. Use the levelling function to drive the platform out from under the boom.
14. Drive the boom down to transport support. Lift the jib if necessary.
15. Resume normal operation from LCB or UCB control centre.



NOTICE

The machine must be driven out of the shortened transport position in the same operating mode. In normal operating modes, controls are disabled when stabilisers are up and boom is not on the transport support.

6. DINO SKY RACK (OPTION)

Dino Sky Rack is a DINO accessory intended for lifting of panels of sheet material and pipes.

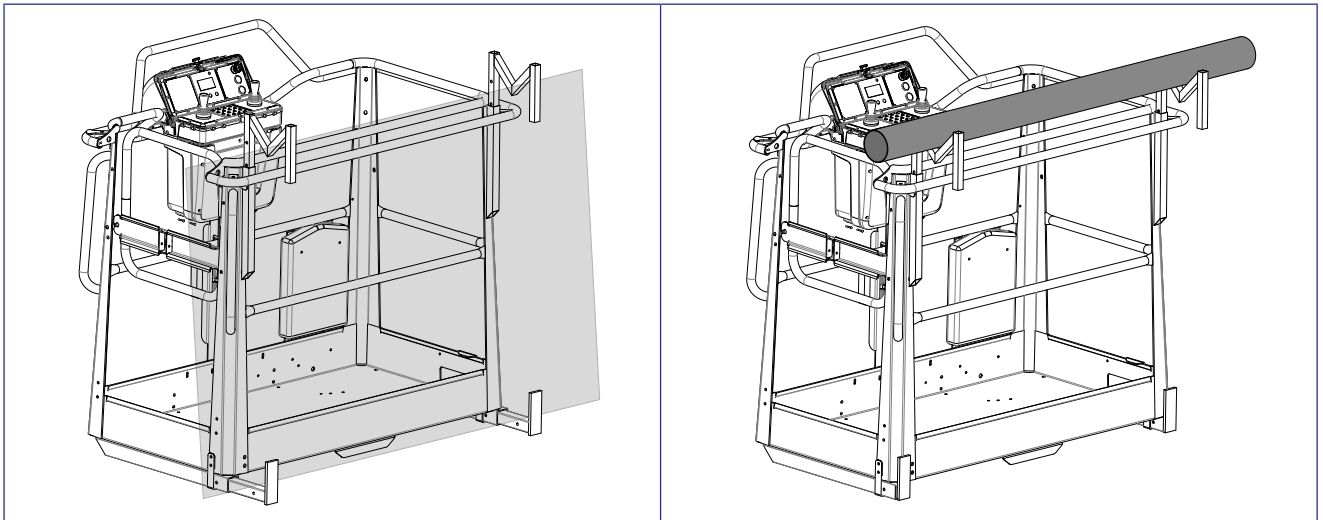

Technical specifications

	160 XT/XTB , 180XT/XTB , 210XT/XTB 280RXT
Max number of persons on platform	1
Max. allowed load on rack	100 kg
Max. panel area	3 m ²
Max. panel height	1250 mm
Max. wind speed during operation	7 m/s
Weight of the Sky Rack	6 kg

Before operation:

- Check, that the upper and lower supports are not bent or otherwise damaged.
- Check that the locking pins are in place in all supports.

Lifting panels:

1. Place the lower supports to their desired positions. Secure the supports with locking pins.
2. Load the panel on the rack
 - center the load on the platform
 - place it on at least two of the lower supports
1. Turn the upper supports outside of the platform railing. Place the supports on desired height so that the panel can not tip over. Secure all supports with locking pins.
2. If necessary, secure the panel with straps so that it can not fall off during lifting.

Lock upper and lower supports in their shortest position when the rack is not in use.



DANGER

Tip over hazard!

The panels will increase the area exposed to wind and decrease the stability of the machine. Follow all instructions on maximum panel size and operating conditions.

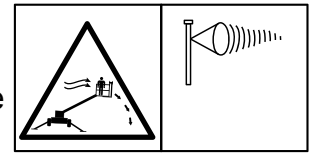

Lifting pipes:

1. Place the lower supports to the shortest position. Secure the supports with locking pins.
2. Turn the upper supports outside of the platform railing and place the supports on desired height. Secure the supports with locking pins.
3. Load the pipe on the rack
 - center the load on the platform
 - place it on at least two of the upper supports
4. Secure the pipe with straps so that it can not fall off during lifting

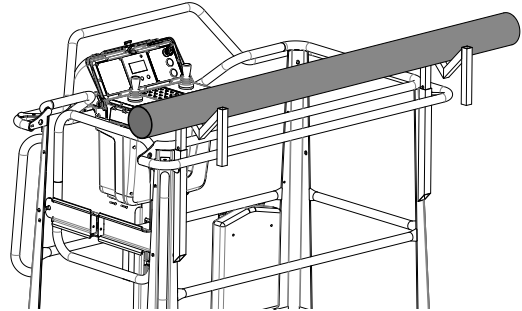

WARNING

The weight of the Sky Rack assembly, load on the rack and load on the platform must not exceed the maximum allowed load on the platform of the machine!

When the SkyRack is not in use:

1. Turn the upper supports between the handrails.
2. Place the upper supports in the lowest position. Secure the supports with locking pins.
3. Place the lower supports to the shortest position. Secure the supports with locking pins.

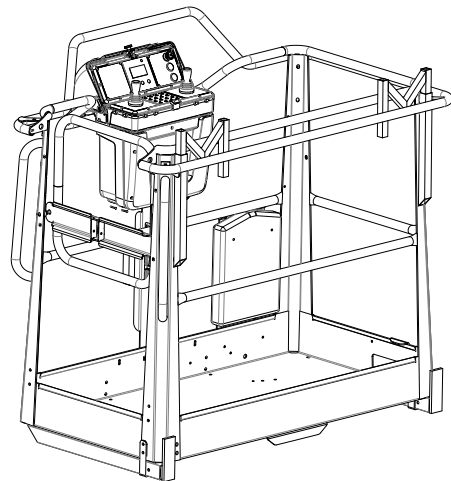

Maintenance

- Check supports for bent, crushed or missing parts
- Replace damaged or missing parts
- Replave illegible or missing decals

7. DINO SAFE-GUARD (OPTION)

Upper control centre can be equipped with a safe-guard. The device helps to protect the user from entrapment and crushing hazards while driving or working near obstructions.

The safe-guard stops the machine in case the safety line over the controls is pushed so that the magnet at the end of the line is released from the socket.

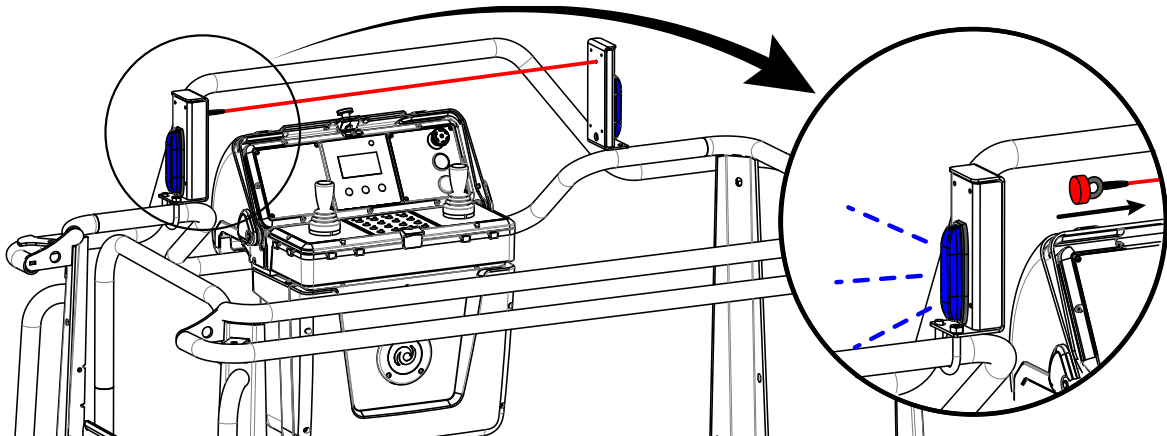

Once the magnet is released, the safe guard stops all movements. Activating the safe-guard can also trigger a visible and audible alarm.

After the safe-guard has stopped the movements, only safe movements remain operational:

- jib arms down
- articulated arms down
- telescope retraction
- main boom down

Additionally the machine can be driven from the LCB center with the emergency descent system.

Once the line is re-connected, the machine can be used normally.

8. FAULT FINDING

FAULT	REMEDY
-------	--------

1. The engine does not start

The main current is not connected.	Switch on the main switch and activate the system by depressing the pedal switch (UCB) or by pressing the activation button (LCB).
Lights flash on all control system buttons. Light in the LCB emergency stop -button is off. The machine is in emergency stop -mode.	Check that all emergency stop -buttons are up on all control stations. Try to re-start the engine.
The engine starts and the display blacks out for a moment.	Check the battery voltage
The following text appears on the display: WATER TEMP: HIGH.	Let the engine cool down. Check the coolant level and the air flow to the cooler.
Fuel tank is empty. The following text appears on the display: FUEL LEVEL: LOW	Refuel and bleed the fuel supply system.



2. The engine starts but stops for a while

The following text appears on the display: OIL PRESS LOW.	Check the engine oil level.
---	-----------------------------

3. None of the stabilisers move

The boom system is not in transport position.		If the stabilisers are up, check the red signal light on the retraction button. If the light flashes, the telescope is not fully in. Retract the telescope by pushing the button.
		If the stabilisers are down, check that the telescope is in, boom and articulated arms are down and the turning device is aligned with the chassis.

4. Disturbance of platform movements - only some of the movements are operational

The stabilisers are not pressed down properly.		Make sure that all the stabilisers are steadily supported on the ground. Check the stabiliser status from the display.
The chassis is not levelled within the allowed inclination limit. Inclination warning light is flashing.		Level the chassis within the allowed limit. Check the inclination angle from the display.
Overloading of the boom has occurred. Overload warning light is flashing.		Return to the outreach area allowed for the load by retracting the telescope. Reduce load on the platform.
Telescope out -movement is not working.		Telescope out -movement is prevented when the boom is on the support. Lift the boom from the support and try again.

8.1. OPERABILITY OF MOVEMENTS

	Sensors controlling the operability	Drive + steering movements ²	Stabiliser movements	Boom Rotation	Articulated arms Up	Articulated arms Down ¹	Main Boom Up	Main Boom Down ¹	Telescope In ¹	Telescope Out	Jib arms	Manual levelling of platform	Platform Rotation	Sound signal	Signal lights
Stabilisers up	RK11-14	ON	ON	OFF	OFF	OFF	OFF	OFF	OFF	OFF	ON	ON	ON	OFF	OFF
Stabilisers down	RK11-14	OFF	ON	ON	ON	ON	ON	ON	ON	ON	ON	ON	ON	OFF	DISP
Boom rotation center position, telescope in	RK1, RK2	ON	ON	ON	ON	ON	ON	ON	ON	ON	ON	ON	ON	OFF	OFF
Boom rotation turned	RK1, RK2	OFF	OFF	ON	ON	ON	ON	ON	ON	ON	ON	ON	ON	OFF	OFF
Telescope out	RK8	OFF	OFF	ON	ON	ON	ON	ON	ON	ON	ON	ON	ON	OFF	OFF
Boom + Articulated arms down	RK3	ON	ON	ON	ON	ON	ON	ON	ON	OFF	ON	ON	ON	OFF	OFF
Boom + Articulated arms up	RK3	OFF	OFF	ON	ON	ON	ON	ON	ON	ON	ON	ON	ON	OFF	OFF
Chassis inclination: starting aerial operation >1deg	RK30	OFF	OFF	OFF	OFF	ON	OFF	OFF	ON	OFF	ON	ON	ON	OFF	1/s
Chassis inclination during operation <1deg	RK30	OFF	OFF	ON	ON	ON	ON	ON	ON	ON	ON	ON	ON	OFF	OFF
Chassis inclination during operation 1 - 5deg	RK30	OFF	OFF	ON	ON	ON	ON	ON	ON	ON	ON	ON	ON	OFF	1/s
Chassis inclination during operation > 5deg	RK30	OFF	OFF	OFF	OFF	ON	OFF	OFF	ON	OFF	ON	ON	ON	ON	1/s
Chassis inclination during driving 0 - 25deg	RK30	ON	ON	OFF	OFF	OFF	OFF	OFF	OFF	OFF	ON	ON	ON	OFF	OFF
Chassis inclination during driving > 25deg	RK30	ON	ON	OFF	OFF	OFF	OFF	OFF	OFF	OFF	ON	ON	ON	ON	1/s
Inside moment limit	B1-4, RK32	OFF	OFF	ON	ON	ON	ON	ON	ON	ON	ON	ON	ON	OFF	OFF
Outside moment limit	B1-4, RK32	OFF	OFF	ON	ON	ON	ON	OFF	ON	OFF	OFF	ON	OFF	ON	1/s / ON
Outside length limit	RK8	OFF	OFF	ON	ON	ON	ON	OFF	ON	OFF	OFF	ON	OFF	ON	1/s / ON

Optional warning signals:

¹ Warning for boom lowering movements (option).

- Works while driving boom movements (marked with ¹ in the table) from the UCB controls.
- Warning buzzer sounds on ground level to warn pedestrians in the area.

² Warning for driving (option)

- Works while driving the machine.
- Uses a sound signal, warning beacons or both

8.2. FAULT CODES

The machine has a self diagnostic system that monitors the state of the machine and the control system.

When a fault code is active, the lights on the display panel buttons flash and a pop up message will appear on display. Depending on the fault, the diagnostic system can also limit the operability of movements while a fault code is active.

If a fault code has been triggered for example by a temporary fluctuation in control signal or system pressure:

- Reset the system by pressing the emergency stop button or switching off the main switch.
- Start the machine normally.

If the fault code does not appear again after re-start, the machine can be operated normally. For more detailed information about fault codes and their effects, see the maintenance manual.

To avoid most common fault causes:

- Keep the battery well charged.
- Warm the engine and oils up before operation in cold conditions.
- Do not open the hydraulic reservoir or connections unnecessarily.
- Fix loose bolts and electric connections if you notice them.
- Keep all covers and electric boxes closed at all times. Moisture in the system can cause contact failures.
- Lubricate the necessary points regularly.
- Follow the maintenance schedule.
- **KEEP THE LIFT CLEAN AND PROTECT IT AGAINST MOISTURE.**

NOTES

2. SERVICING AND MAINTENANCE

Maint.	Schedule	Person responsible	Reference
A	Daily	Operator	Operating instructions
B	1 month / 100 hours*	Competent person who is familiar with the lift	Maintenance instructions
C	6 months / 400 hours*	Competent person who is familiar with the lift	Maintenance instructions
D	Annually / 800 hours*	Skilled technician who is well familiar with the structure and operation of the lift	Maintenance instructions
E	As needed	Skilled technician who is well familiar with the structure and operation of the lift	Maintenance instructions

* Service must be performed every indicated month or operating hour interval, whichever comes first.

NOTICE

In addition to daily maintenance, every user must do a worksite inspection before operating the lift.

C = Check (general checking of condition).

I = Thorough Inspection. Performed according to separate procedure described in maintenance instructions.

M = Maintenance work, such as lubrication, adjustments or replacements

Always lubricate the lift and apply a protective grease film immediately after the washing.

Special inspection is required if the lift has been damaged in a manner which may affect its load-bearing capacity or safe operation. For further instructions, see the maintenance instructions manual.

NOTICE

If the lift is operated under demanding conditions (in exceptionally humid or dusty environment, corrosive climate, etc.), the intervals between the oil changes and the other inspections shall be shortened to meet the prevailing conditions in order to maintain the operational safety and reliability of the lift.

	Maintenance item	A	B	C	D	E
1	Chassis structures, boom and work platform	C	C	C	I	
2	Telescopic boom		C/M	C/M	C/M	
3	Cylinders				I	
4	Turning device and rotating adapter			M	I/M	
5	Axles and wheels	C	C/M	C/M	I/M	
6	Engine	C	C/M	C/M	C/M	
7	Hydraulic oil	C	C	C	M	
8	Hydraulic system	C	C	C	I	
9	Load holding and load regulation valves		C		I	
10	Platform levelling system				C	
11	Electrical system and control devices	C	C	C	I	
12	Safety devices	C	C	C	I	
13	Signs, labels and machine plates	C	C	C	C	
14	Instruction manuals	C	C	C	C	
15	Test loading				M	
16	Corrosion protection				C	M
17	Special inspection					M

NOTICE

Check the engine manual for full information on maintenance procedures required by the engine.

2.1. LUBRICATION PLAN

DINO 220-280RXT

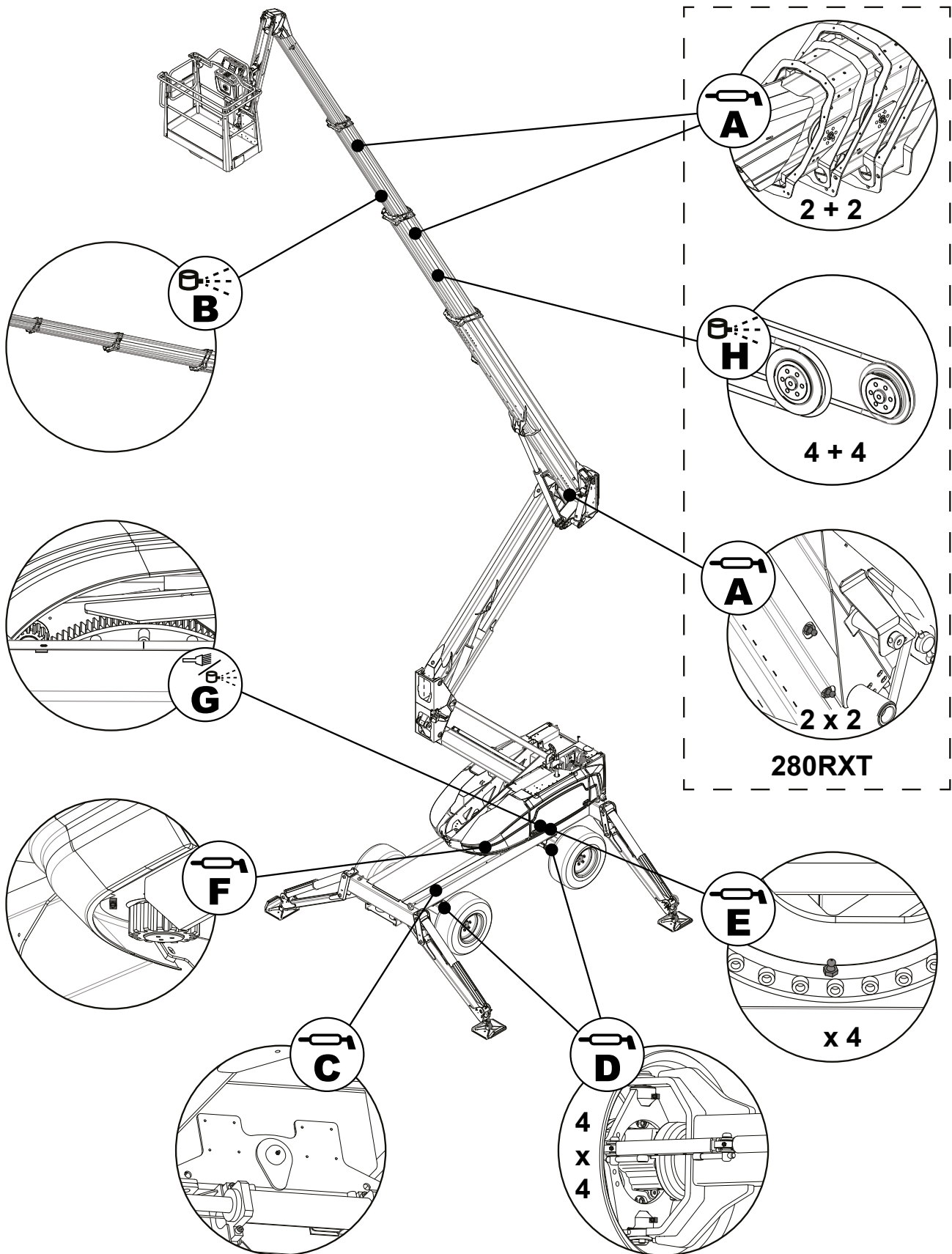

2.2. INSPECTIONS REQUIRED BY AUTHORITIES

Inspections must be performed in accordance with local, state or federal regulations, legislation, directives, standards. The manufacturer recommends following inspections, as required by local authorities in platforms country of origin.

A pre-use inspection must be done before taking the platform to use for the first time and before first start-up after major repairs and alterations.

A thorough inspection and a test loading of the lift must be carried out at least once every twelve (12) months.

The platform should undergo a major inspection within ten (10) years after having been originally put into service. A major inspection includes non-destructive testing and inspection while dis-assembled.

A special inspection should be done if the platform has been exposed to exceptional circumstances which may have affected the structural integrity of critical components.

The inspections should be carried out on regular basis throughout the service life of the lift. If the lift is used under extreme conditions, intervals between the inspections shall be reduced.

The overall operating condition of the lift as well as the condition of the safety-related control devices shall be established in the regular inspections. Particular attention shall be paid to changes which affect the operational safety.

During inspections the notifications given in previous inspections, practical experience from use and information on performed repairs should be taken into account and can be implemented for better safety.

Major and special inspections shall be carried out by a competent person or competent body, who is familiar with the operation and structure of the lift. The competent person should periodically update their knowledge and be able to demonstrate their competency if so required.

A report should be made of the inspections and the reports should be kept with the unit stored in the space reserved for it.

The report should include

- information about the inspection
- data of repair welds (date, what was repaired and repaired by whom)

When the lift is ready for operation after annual inspection, the date of inspection shall be marked on the inspection plate affixed to the lift.

NOTICE

Always check the local, state or federal regulations about aerial platform inspections and inspector qualifications from local authorities.

3. ROUTINE MAINTENANCE DURING OPERATION

This chapter describes the service and maintenance operations that the operator of the platform is responsible for.

Other maintenance operations require special training, tools and materials or specific measurements and adjustment values. They are separately described in maintenance instructions manual. Please contact your maintenance partner, dealer or manufacturer.

Make sure that all service and maintenance procedures are performed in time and according to instructions.



WARNING

Any faults which may affect the operational safety of the unit must be repaired before the lift is used for the next time.

Keep the lift clean. Clean the lift carefully before any service and maintenance operations or inspections. Impurities may cause serious problems in for example in the hydraulic system.

Use original spare parts and service kits. See spare part list for detailed information on spare parts.

The first service after 50 hours of operation

- Change the pressure- and return filter elements (3) in hydraulic system
- Change engine oil and oil filter cartridge

If the lift is operated under demanding conditions (in exceptionally humid or dusty environment, corrosive climate, etc.), the intervals between the oil changes and the other inspections shall be shortened to meet the prevailing conditions in order to maintain the operational safety and reliability of the lift.

The performance of the periodic servicing and the inspections is absolutely mandatory, because their negligence may impair the operational safety of the lift.

The guarantee will not remain valid, if the servicing and the periodic inspections are not performed.

3.1. DAILY MAINTENANCE TASKS

3.1.1. Chassis, boom and work platform

Check the overall condition of access systems, work platform, gate and handrails.
Check that the chassis, stabilisers and boom system have no visible signs of structural damage.

280RXT: Check, that the mechanical indicators for wire-rope failure are aligned properly. The machine must be in transport position, telescopic boom fully retracted.

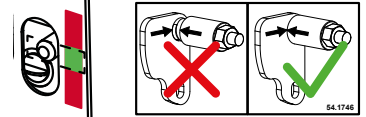

3.1.2. Axles and wheels

Check the condition of the tyres visually and check that they are not flat.

3.1.3. Fuel and hydraulic oil levels

Check the amount of fuel and coolant and check that there are no signs of oil or fuel leaks.

Check the hydraulic oil level while the platform is in transport position. Add oil if needed.

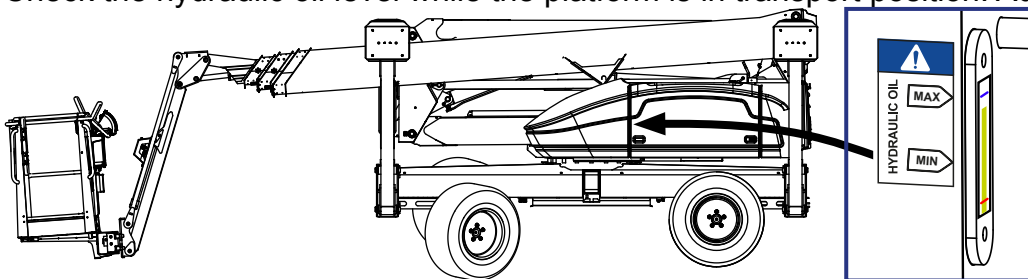

3.1.4. Electrical and hydraulic systems

Check the condition of hydraulic hoses, pipes and connections visually.
Make sure that there are no visible oil leaks.

Check that the electrical components, housings or wiring do not show any visible signs of damage.

Any externally damaged components, hoses, clashed pipes and connections or loose or damaged wiring must be changed before operation.

3.1.5. Control system and safety devices

Check, that

- the control system is operational and that it gives no error codes. Lights on the buttons below the display will flash, if any fault codes are active.
- all the controls and functions work as they should
- the chassis inclination, stabiliser display and outreach display change logically during operation.

Test the correct operation of emergency stop, emergency descent system and the sound signal from the lower controls and platform controls.

- Lift the boom up approximately 1-2 meters and drive the telescope out 1-2 meters.
- While driving the movement, push down the emergency stop button. The movement should stop and the engine shut down.
- Lift up the emergency stop button
- Drive the telescope in and lower the boom by using emergency descent
- Test the sound signal from the platform

3.1.6. Signs, labels and machine plates

Make sure, that all the signs, plates and instructional and warning labels on control stations are intact, clean and legible.

If the labels have started to come off or tear apart or if the symbols or texts are illegible the labels must be replaced as soon as possible.

3.1.7. Instruction manuals

Check that the instruction manuals accompanying the platform are correctly stored on the platform and that they are legible.



BLANK



11. CHANGE OF OWNER

For the owner of the lift:

If you have purchased a used DINO lift from some other than the manufacturer, please post your details to the manufacturer using the form on this page, and send it to:

info@dinolift.com

This information makes it possible for us to provide you with the safety bulletins and other campaigns relevant to your machine.

Note! It is not necessary to inform about a rented machine.

Machine model: DINO _____

Serial number: _____

Previous owner: _____

Country: _____

Date of purchase: _____

Current owner: _____

Address: _____

Country: _____

Contact person

Name and position in the company: _____

Telephone: _____

E-mail: _____

NOTES

NOTES