

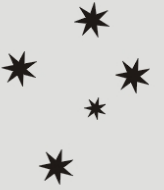

**Dingli Australia**

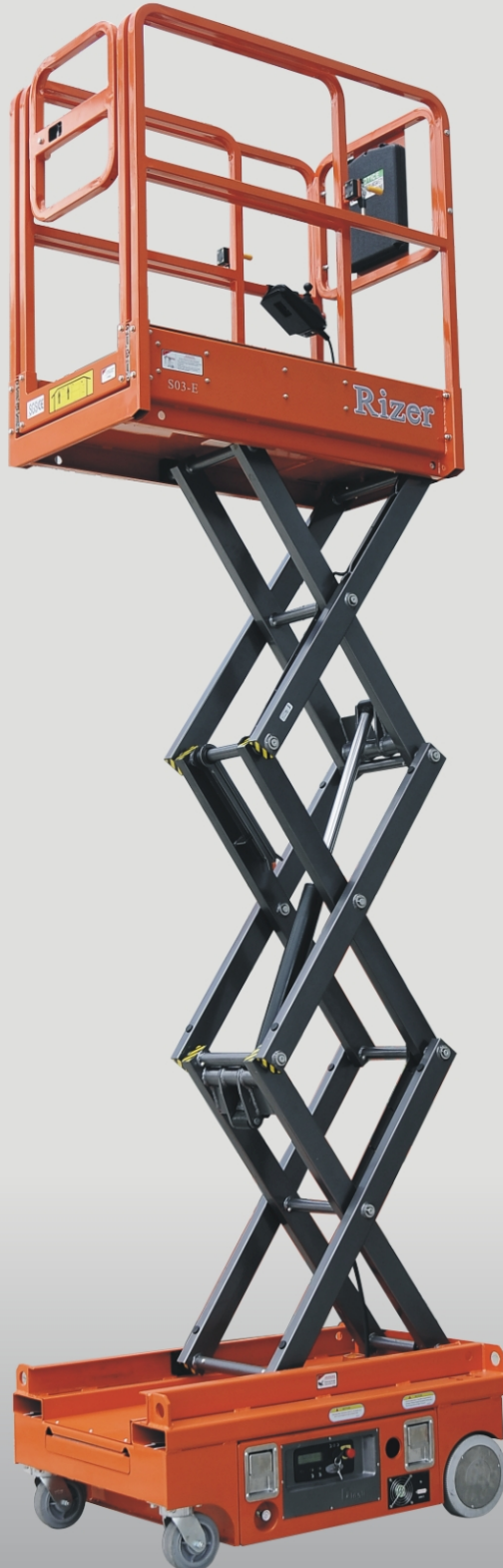

[www.dingliaustralia.com.au](http://www.dingliaustralia.com.au)



# **Rizer**

---

## **S03-E**

# ELECTRIC SCISSOR LIFTS

# Rizer

## S03-E

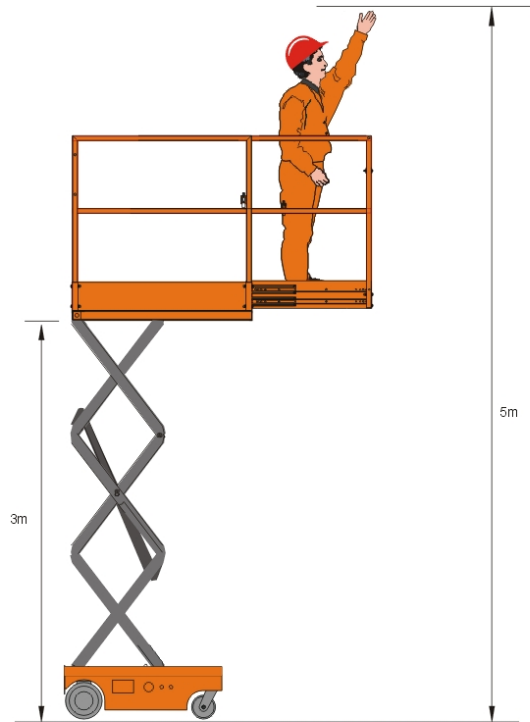
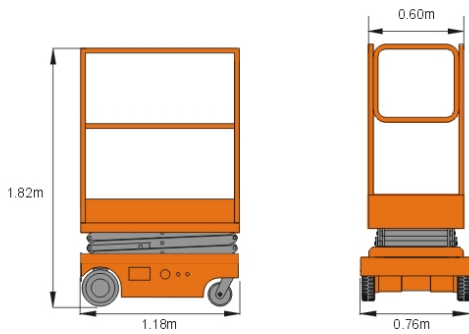

<b>S.W.L</b>	240 kg/529lb
--------------	--------------



<b>Working height</b>	5.00m/16ft4in
<b>Platform floor height</b>	3.00m/9ft10in



<b>Overall length</b>	1.18m/3ft10in
<b>Overall width</b>	0.76m/2ft6in
<b>Overall height</b>	1.82m/5ft11in
<b>Platform size</b>	1.17X0.60m/3ft10inx1ft11in
<b>Ground clearance</b>	0.06m/2.3in
<b>Wheelbase</b>	0.99m/3ft3in
<b>Turning radius</b>	0



<b>Drive motors</b>	2X24VDC/0.4kw
<b>Lifting motor</b>	24VDC/0.8kw



<b>Travel speed</b>	
Stowed	4 Km/h 2.5miles/h
Raised	0.8 Km/h 0.5miles/h
<b>Up/Down speed</b>	28/41 sec



<b>Batteries</b>	2X12V/95Ah
<b>Integrated charger</b>	24V/12A



<b>Gradeability</b>	30%
---------------------	-----



<b>Tyres</b>	
Drive motors	φ 230X80mm



<b>Weight</b>	495kg/1091lb
---------------	--------------

### Standard equipment

- Proportional controls
- Automatic pothole protection
- Self-lock gate on platform
- Drivable at full height
- Non marking tyres
- 2WD
- Automatic brakes
- Emergency lowering system
- Emergency stop buttons
- Cylinder holding valve
- Onboard diagnostic system
- Tilt sensor with alarm
- All motion alarm
- Horn
- Hour meter
- Safety brackets
- Forklift pockets
- Extended platform
- Charger protection
- Flashing beacon

