

“Let us be an asset to your business”

## PORTABLE GENERATOR SAFETY SHEET

(Atlas Copco P2000i)



**PLEASE READ THIS GUIDE CAREFULLY BEFORE OPERATING THE EQUIPMENT**

### IMPORTANT - CONDUCT A RISK ASSESSMENT

Before you commence any work at your chosen work area, you should undertake some preliminary hazard identification and risk control precautions. Ideally more than one person should do this. This is undertaken by:

1. Physically inspecting the work site
2. Reviewing the best way/job steps required to complete the task
3. Reviewing the Safe Work Information supplied with the equipment
4. Reviewing other reference documentation and expert advice.

The hazard identification and control process steps are defined as:

1. Identify the Hazards (eg. 240V power drill use around wet areas)
2. Assess the Risk (multi earth paths - possible electrocution)
3. Select the Control Measure (e.g. dry the area; use an RCD; use a cordless drill etc)
4. Re-assess the Risk (risk of electrocution now negligible). This is undertaken to ensure that the risk control measures adopted have not introduced any new risks to the work area.

### SAFETY INFORMATION

Generators are designed for use with electrical equipment that has suitable power requirements. Other uses can result in injury to the operator or damage to the generator and other property.

- Place the generator on a firm level surface before operations.
- Do not operate the generator with any cover removed.
- Exhaust contains poisonous carbon monoxide, a colorless, odorless gas. Breathing exhaust can cause loss of consciousness and may lead to death.
- Do not run the generator in an area that is confined, or even partially enclosed. The air you breathe could contain dangerous amounts of exhaust gas. Do not operate it inside a garage, house, or near open windows or doors.
- The generator produces enough electric power to cause a serious shock or electrocution if misused. Do not use it in wet conditions, such as rain or snow, or near a pool or sprinkler system, or when your hands are wet. Keep the generator dry.
- Do not use the generator in areas with a high risk of fire. Keep the generator at least 1 meter away from buildings and other equipment during operation. Keep all flammable materials away from the generator.

### PERSONAL PROTECTION EQUIPMENT (PPE)



PROTECTIVE GLOVES



HEARING PROTECTION

### HELP AND SUPPORT

If the unit does not operate correctly or you are unhappy with its performance, return it to Asset Construction Hire for an exchange, or phone for assistance. Do not attempt repairs yourself.

**Asset Construction Hire**

Phone: 1300 361 383 or email: [office@assethire.com.au](mailto:office@assethire.com.au)

### OPERATION MANUAL

A PDF of the full Operation Manual is available at: [www.assethire.com.au/manuals-specs-safety-sheets/](http://www.assethire.com.au/manuals-specs-safety-sheets/) and must be read before using the equipment.

### BEFORE OPERATING THE EQUIPMENT:

- Read this Safety Sheet and any other information provided with the equipment, including instructions, decals and operation guidelines.
- Check that you understand how and when to use the equipment, and know how to operate it safely.
- Ensure that it is only used according to the manufacturers and hirer's instructions, and only for work that is compatible with its technical limitations.
- Operate in a clear work area free from nonessential persons, children, animals or hazards.
- Ensure that you have a secure footing and clear access and egress to the work area while on the job.
- Do not operate any equipment if you are tired or suffering any medical condition, or if under the influence of drugs or alcohol which may cause lethargy or dangers to yourself or others.
- Do not use faulty equipment. If in doubt contact Asset Construction Hire.

- Some parts of the internal combustion engine are hot and may cause burns. Pay attention to the warnings on the generator.
- Do not touch the muffler during or after operation, while it is hot.
- Do not pour water on the generator in the event of a fire. Use an appropriate fire extinguisher specially designed for electric fire or oil fire.
- If you inhale fumes produced by an accidental fire with the generator, consult a doctor and seek medical treatment immediately.
- Only refuel the generator outdoors, in a well ventilated area with the engine off.
- Do not refuel during operation, and do not overfill the tank.
- Never smoke near gasoline, and keep all flames and sparks away.



• **Connections for standby power to a building's electrical system must be made by a qualified electrician and must comply with all applicable laws and electrical codes. Improper connections can allow electrical current from the generator to back feed into the utility lines. Such back feed may electrocute utility company workers or others who contact the lines during a power outage, and when utility power is restored, the generator may explode, burn, or cause fires in the building's electrical system.**

## PORTABLE GENERATOR BASIC INSTRUCTIONS

(Atlas Copco P2000i)

### PRE-OPERATION CHECK

**1. Check the engine oil level (4-stroke motor oil).**

- Ensure the machine is off and on a level surface.
- Remove the screws (1) and the oil filler cap (3).
- Fill with the specified amount of SAE 10W-30 oil.

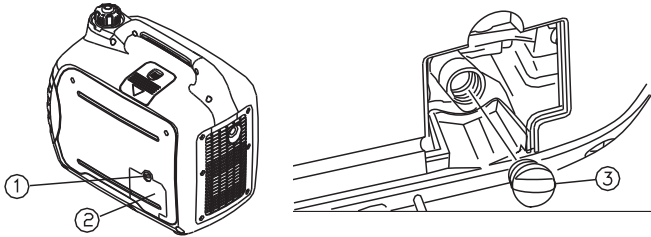

**2. Check the fuel level.**

- Remove the fuel tank cap and fill to the red mark (1) to achieve the correct fuel level (2).

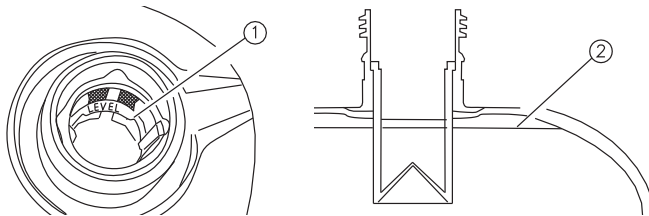

### STARTING THE ENGINE

**1. Before starting, ensure the ESC switch is OFF (1).**

**2. Turn the air vent knob to on (2).**

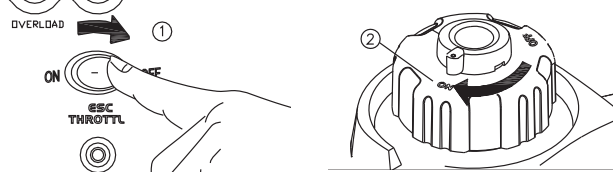

**3. Turn the three in one switch to “CHOCK” (3).**

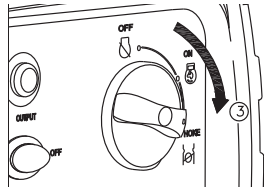

**4. Pull slowly on the recoil starter until it is engaged, then pull it briskly. Hold the carrying handle with one hand to prevent the unit falling over.**

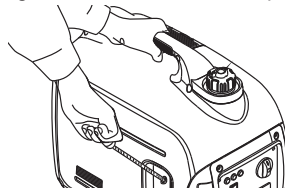

**5. Warm up the engine until it does not stop if the chock knob is returned to the “ON” position (4).**

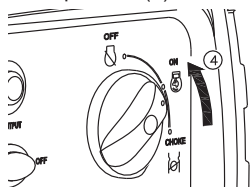

### STOPPING THE ENGINE

**1. Disconnect any electric devices and turn the ESC switch to off (1).**

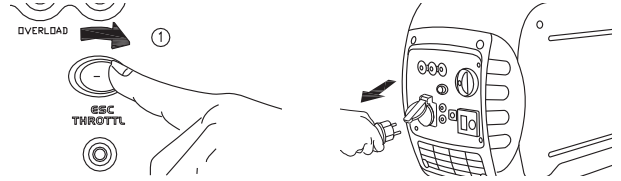

**2. Turn the 3 in 1 switch to OFF (2).**

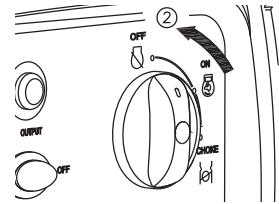

**3. Turn the fuel tank cap air vent knob to OFF (3) after the engine has cooled down.**

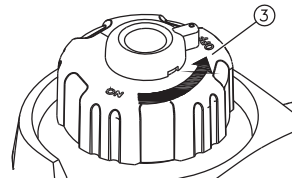

### MAIN COMPONENTS

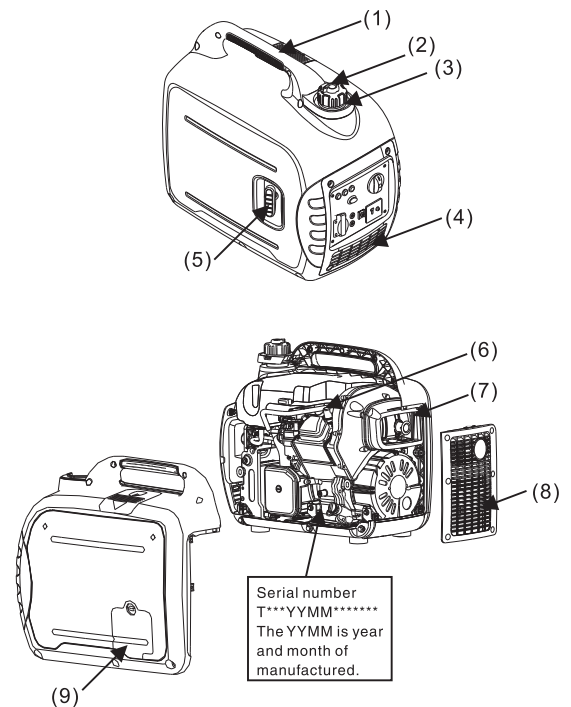

- |                                 |                      |
|---------------------------------|----------------------|
| (1) Handle                      | (5) Recoil starter   |
| (2) Fuel tank cap air vent knob | (6) Spark plug       |
| (3) Fuel tank cap               | (7) Muffler          |
| (4) Control panel               | (8) Louver           |
|                                 | (9) Oil filler decal |